



标准规格书

RA005L-A

创建A 2025年02月13日

川崎重工业株式会社
机器人事业部

规格书编号： 90151-0112DCA

机器人规格

1. 机械型号	RA005L-A																							
2. 手臂形式	垂直多关节型																							
3. 自由度	6轴																							
4. 最大可搬运质量	5kg																							
5. 最大覆盖范围	903mm																							
6. 位置重复精度	±0.03mm (手腕法兰面) 符合ISO9283																							
7. 构成轴规格	<table border="1"> <thead> <tr> <th>动作轴</th> <th>动作范围</th> <th>最大速度</th> </tr> </thead> <tbody> <tr> <td>手臂旋转 (JT1)</td> <td>±180°</td> <td>300°/s</td> </tr> <tr> <td>手臂前后 (JT2)</td> <td>+135°至-80°</td> <td>300°/s</td> </tr> <tr> <td>手臂上下 (JT3)</td> <td>+118°至-172°</td> <td>300°/s</td> </tr> <tr> <td>手腕旋转 (JT4)</td> <td>±360°</td> <td>460°/s</td> </tr> <tr> <td>手腕弯曲 (JT5)</td> <td>±145°</td> <td>460°/s</td> </tr> <tr> <td>手腕扭转 (JT6)</td> <td>±360°</td> <td>740°/s</td> </tr> </tbody> </table>			动作轴	动作范围	最大速度	手臂旋转 (JT1)	±180°	300°/s	手臂前后 (JT2)	+135°至-80°	300°/s	手臂上下 (JT3)	+118°至-172°	300°/s	手腕旋转 (JT4)	±360°	460°/s	手腕弯曲 (JT5)	±145°	460°/s	手腕扭转 (JT6)	±360°	740°/s
动作轴	动作范围	最大速度																						
手臂旋转 (JT1)	±180°	300°/s																						
手臂前后 (JT2)	+135°至-80°	300°/s																						
手臂上下 (JT3)	+118°至-172°	300°/s																						
手腕旋转 (JT4)	±360°	460°/s																						
手腕弯曲 (JT5)	±145°	460°/s																						
手腕扭转 (JT6)	±360°	740°/s																						
8. 手腕轴允许负载	<table border="1"> <thead> <tr> <th></th> <th>最大负载扭矩</th> <th>负载惯性矩*</th> </tr> </thead> <tbody> <tr> <td>JT4</td> <td>12.3N·m</td> <td>0.40kg·m²</td> </tr> <tr> <td>JT5</td> <td>12.3N·m</td> <td>0.40kg·m²</td> </tr> <tr> <td>JT6</td> <td>7.0N·m</td> <td>0.12kg·m²</td> </tr> </tbody> </table> <p>注* 此表中的值表示将允许的最大扭矩施加到手腕各轴时允许的负载惯性矩。有关其他详细信息，请另行咨询本公司。</p>				最大负载扭矩	负载惯性矩*	JT4	12.3N·m	0.40kg·m ²	JT5	12.3N·m	0.40kg·m ²	JT6	7.0N·m	0.12kg·m ²									
	最大负载扭矩	负载惯性矩*																						
JT4	12.3N·m	0.40kg·m ²																						
JT5	12.3N·m	0.40kg·m ²																						
JT6	7.0N·m	0.12kg·m ²																						
9. 质量	37kg (不包括选购件)																							
10. 安装方法	落地式、吊装式																							
11. 安装环境	环境温度：0至45																							
	相对湿度：35至85% (无结露)																							
12. 涂装颜色	相当于孟塞尔 10GY9/1																							
13. 防护等级	IP65相当																							
14. 内置功能	空气配管 (6×2根)																							
15. 选购件	冲击传感器	川崎重工业制造、其他																						
	焊炬支架	350A用/500A用标准支架、其他																						
	内置阀	双/单电磁阀 总计3个电路以内																						
	机械挡块	可变挡块：JT1																						
	指定涂装颜色																							
	安装规格	壁挂式规格																						
	安装基座	300mmH / 600mmH																						
	底板	400mm × 400mm																						

有关维护零件和备件，请另行咨询。

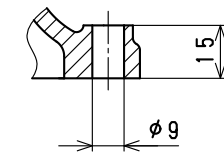
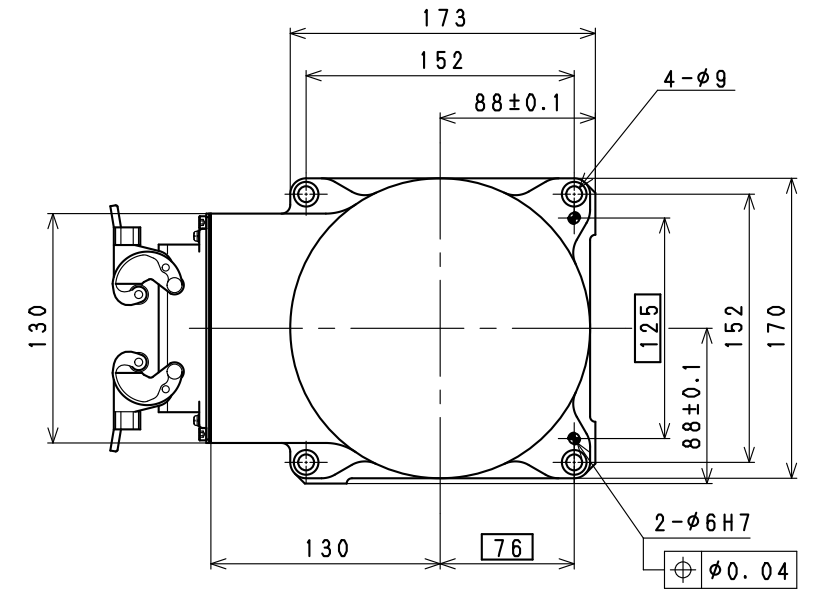
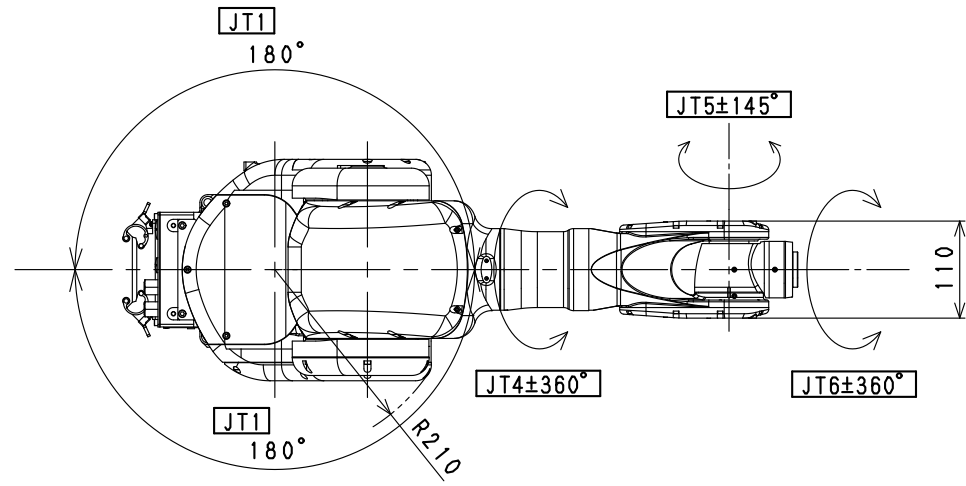

Installation Dimensions

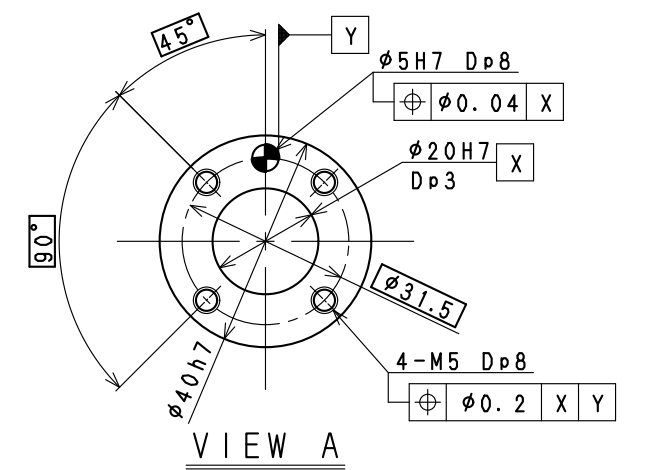
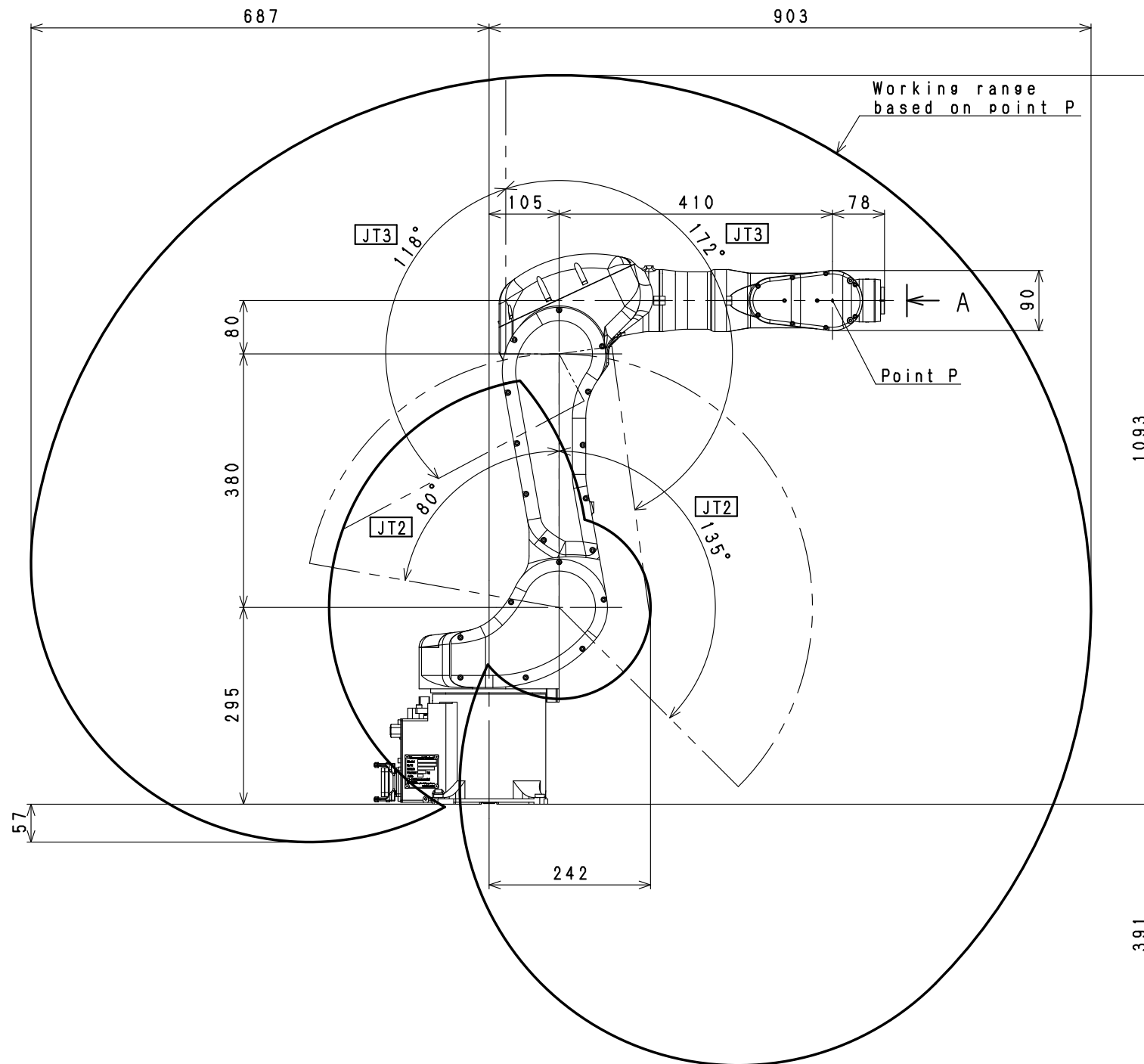
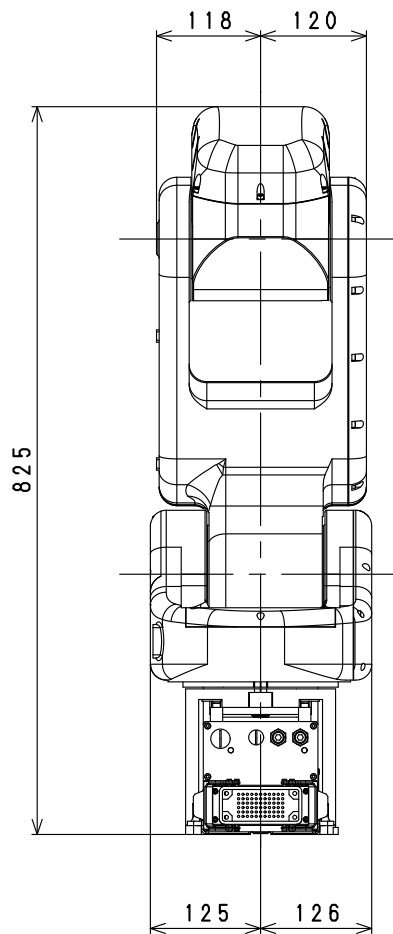

RA005L
 WORKING RANGE