

Standard Specifications

MC004N-B00x

MC004N-B01x

MC004N-B04x

MC004N-B05x

1st ed. 20-Jan-21
2nd ed. 05-Mar-24

Kawasaki Heavy Industries, Ltd.
Robot Business Division

Specification number : 90151-0352DEB

Robot specifications

1. Model	MC004N-Bxxx																						
	B00x	: Air tool specifications (Bottom connector panel)																					
	B01x	: Servo tool specifications (Bottom connector panel)																					
	B04x	: Air tool specifications (Backside connector panel)																					
	B05x	: Servo tool specifications (Backside connector panel)																					
2. Type	Articulated robot																						
3. Degree of freedom	6 axes (option 8 axes ^{*1})																						
4. Max. payload	4 kg																						
5. Max. reach	505.8 mm																						
6. Position repeatability	±0.028 mm (wrist flange surface) conforms to ISO 9283																						
7. Axis specification	<table border="1"> <thead> <tr> <th>Operating axis</th> <th>Motion range</th> <th>Max. speed</th> </tr> </thead> <tbody> <tr> <td>Arm rotation (JT1)</td> <td>±180°</td> <td>200°/s</td> </tr> <tr> <td>Arm out-in (JT2)</td> <td>+ 135° - - 95°</td> <td>180°/s</td> </tr> <tr> <td>Arm up-down (JT3)</td> <td>+ 60° - - 155°</td> <td>225°/s</td> </tr> <tr> <td>Wrist swivel (JT4)</td> <td>±270°</td> <td>700°/s</td> </tr> <tr> <td>Wrist bend (JT5)</td> <td>±120°</td> <td>500°/s</td> </tr> <tr> <td>Wrist twist (JT6)</td> <td>±270°</td> <td>350°/s</td> </tr> </tbody> </table>		Operating axis	Motion range	Max. speed	Arm rotation (JT1)	±180°	200°/s	Arm out-in (JT2)	+ 135° - - 95°	180°/s	Arm up-down (JT3)	+ 60° - - 155°	225°/s	Wrist swivel (JT4)	±270°	700°/s	Wrist bend (JT5)	±120°	500°/s	Wrist twist (JT6)	±270°	350°/s
	Operating axis	Motion range	Max. speed																				
	Arm rotation (JT1)	±180°	200°/s																				
	Arm out-in (JT2)	+ 135° - - 95°	180°/s																				
	Arm up-down (JT3)	+ 60° - - 155°	225°/s																				
	Wrist swivel (JT4)	±270°	700°/s																				
	Wrist bend (JT5)	±120°	500°/s																				
Wrist twist (JT6)	±270°	350°/s																					
8. Load capacity of wrist	<table border="1"> <thead> <tr> <th></th> <th>Max. torque</th> <th>Moment of inertia*</th> </tr> </thead> <tbody> <tr> <td>JT4</td> <td>8.5 N·m</td> <td>0.20 kg·m²</td> </tr> <tr> <td>JT5</td> <td>8.5 N·m</td> <td>0.20 kg·m²</td> </tr> <tr> <td>JT6</td> <td>4.0 N·m</td> <td>0.10 kg·m²</td> </tr> </tbody> </table>			Max. torque	Moment of inertia*	JT4	8.5 N·m	0.20 kg·m ²	JT5	8.5 N·m	0.20 kg·m ²	JT6	4.0 N·m	0.10 kg·m ²									
		Max. torque	Moment of inertia*																				
	JT4	8.5 N·m	0.20 kg·m ²																				
	JT5	8.5 N·m	0.20 kg·m ²																				
JT6	4.0 N·m	0.10 kg·m ²																					
<p>Note* Each value in this table shows allowable moment of inertia of JT4/JT5/JT6 when max. allowed torque is applied to each axis. If more detailed data is required for your application, please contact Kawasaki.</p>																							
9. Mass	25 kg (without options)																						
10. Mounting	Floor or Ceiling mounting																						
11. Installation Environment	Ambient Temperature: 10 - 35 °C																						
	Relative Humidity: 35 - 85 % (with no dew condensation)																						
12. Color	White 12-MTJ-500938 (Epoxy paint)																						
13. Degree of protection	Wrist: IP67 equivalent, Arm: IP65 equivalent																						
14. Cleanliness	ISO class 5																						
15. Built-in utilities	Sensor harness	8 circuits																					
	Solenoid valve ^{*2}	Double / Single solenoid valves (2 units max.)																					
	Air port ^{*2}	2 ports (Rc 1/4)																					
	Pneumatic piping ^{*2}	φ 4 × max 4 lines																					
16. Connector panel	Bottom connected (B00x / B01x), Backside connected (B04x / B05x)																						
17. I/O type	NPN(sink) type																						
18. Options	I/O type	PNP(source) Type																					
	External axis ^{*1}	50W Brushless AC Servomotor (2 units max.)																					

Consult Kawasaki about maintenance parts and spare parts.

*1 Servo tool specifications only

*2 Air tool specifications only

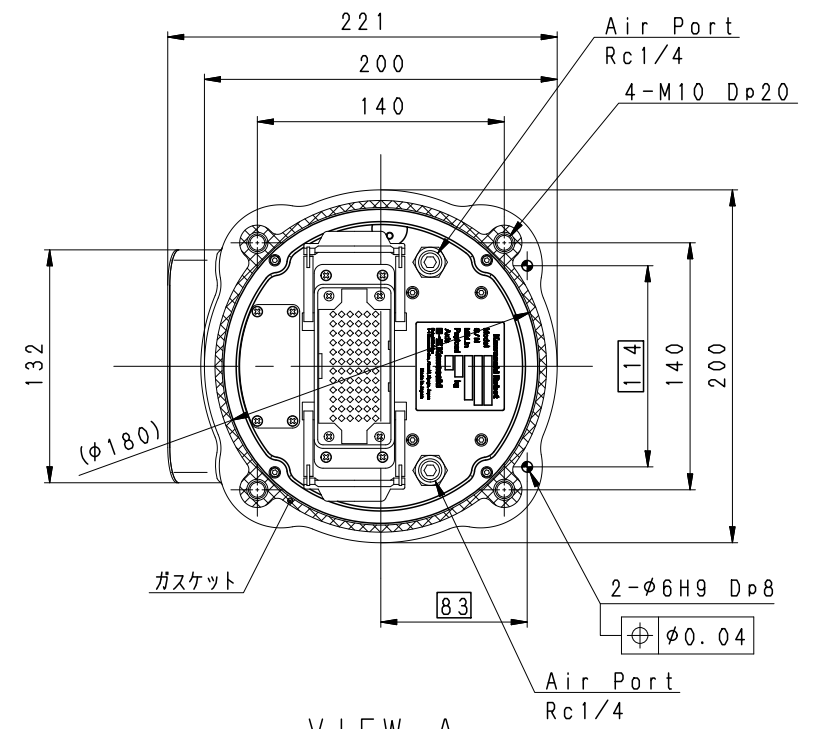
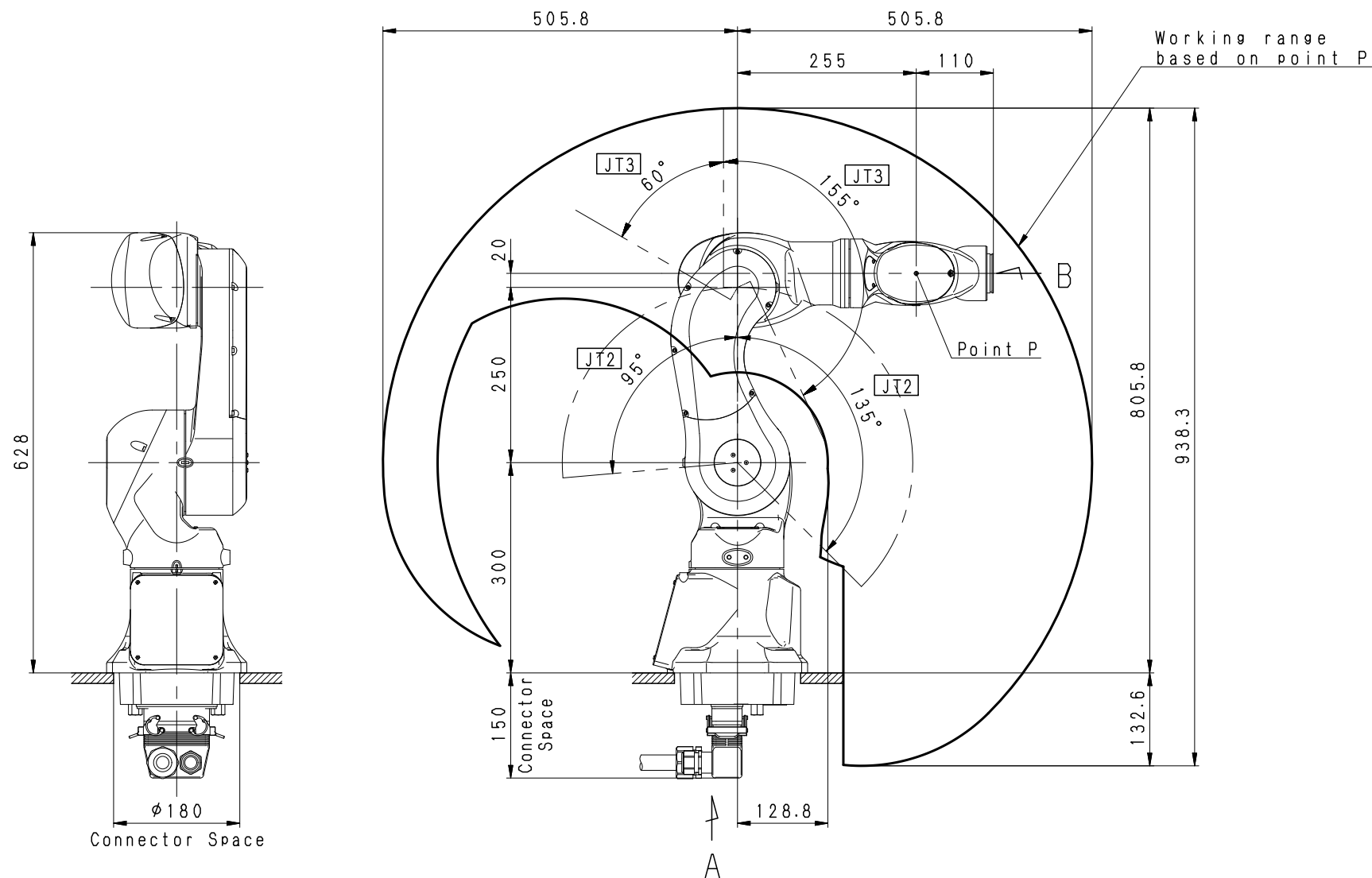
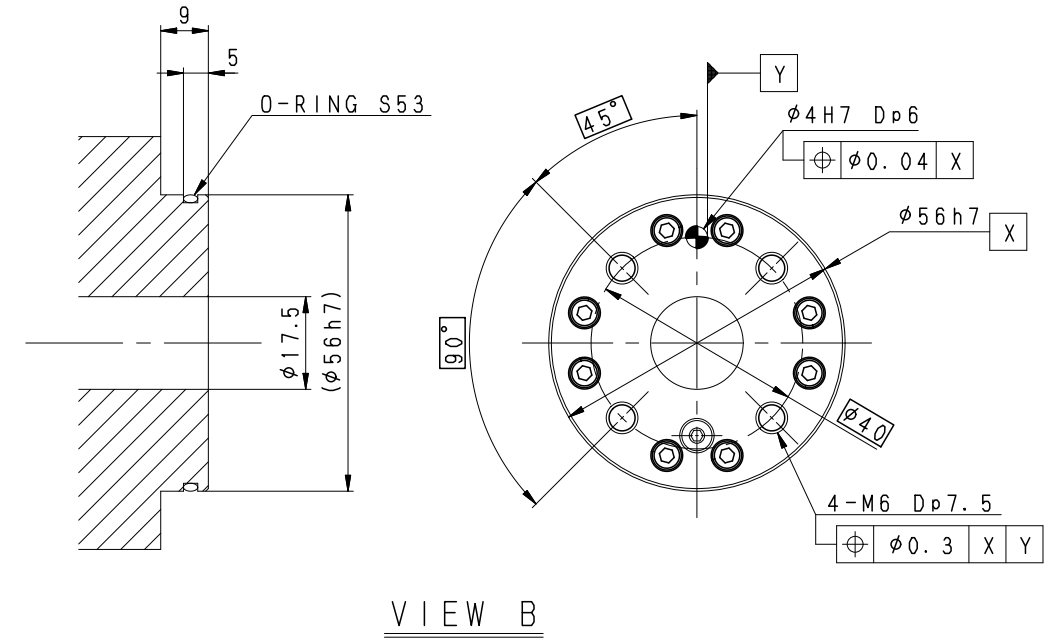
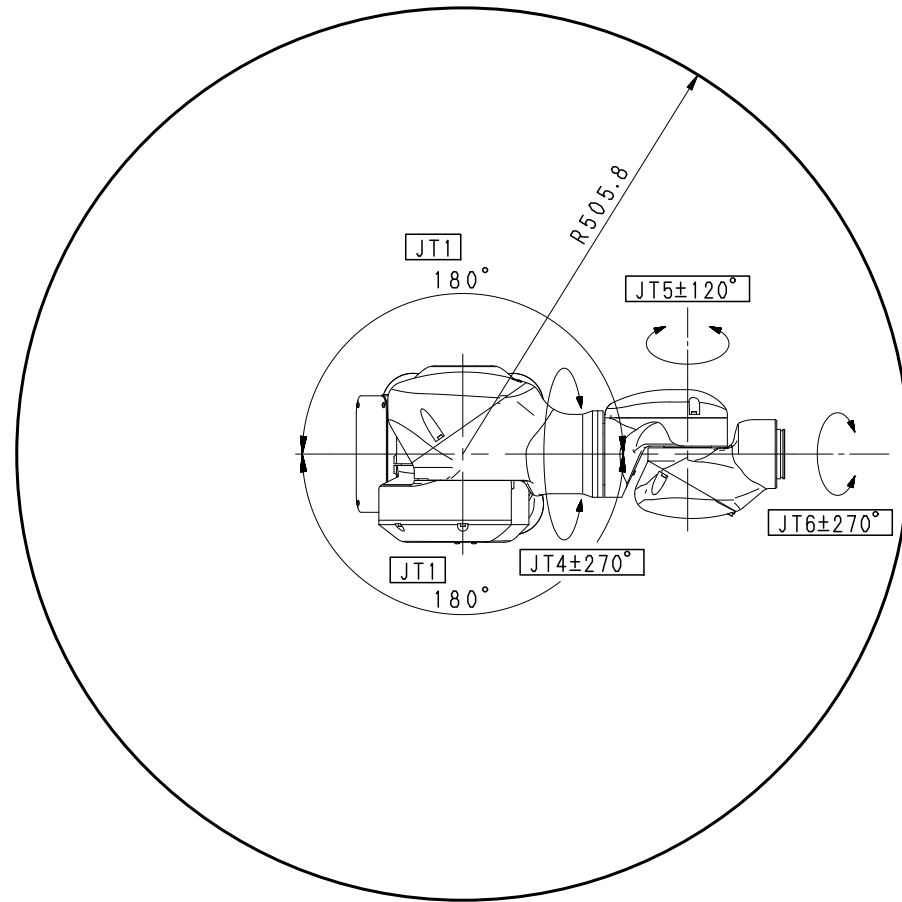

VIEW A
(Installation Dimensions)

**MC004N
WORKING RANGE**

(Bottom connector panel)

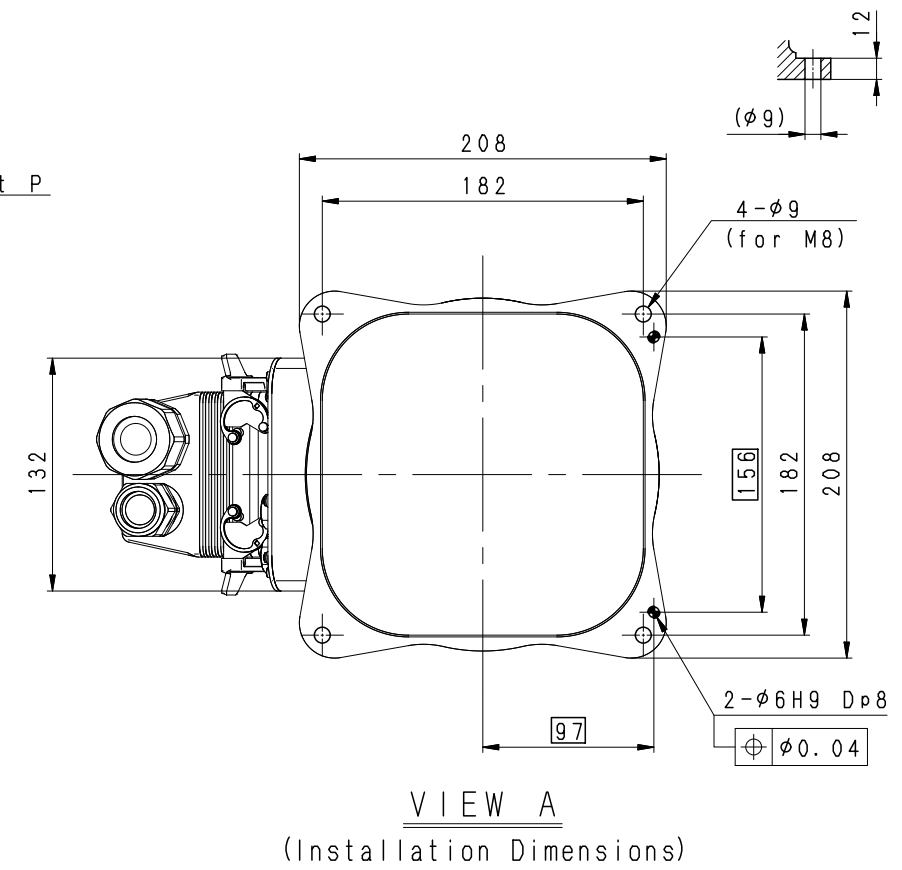
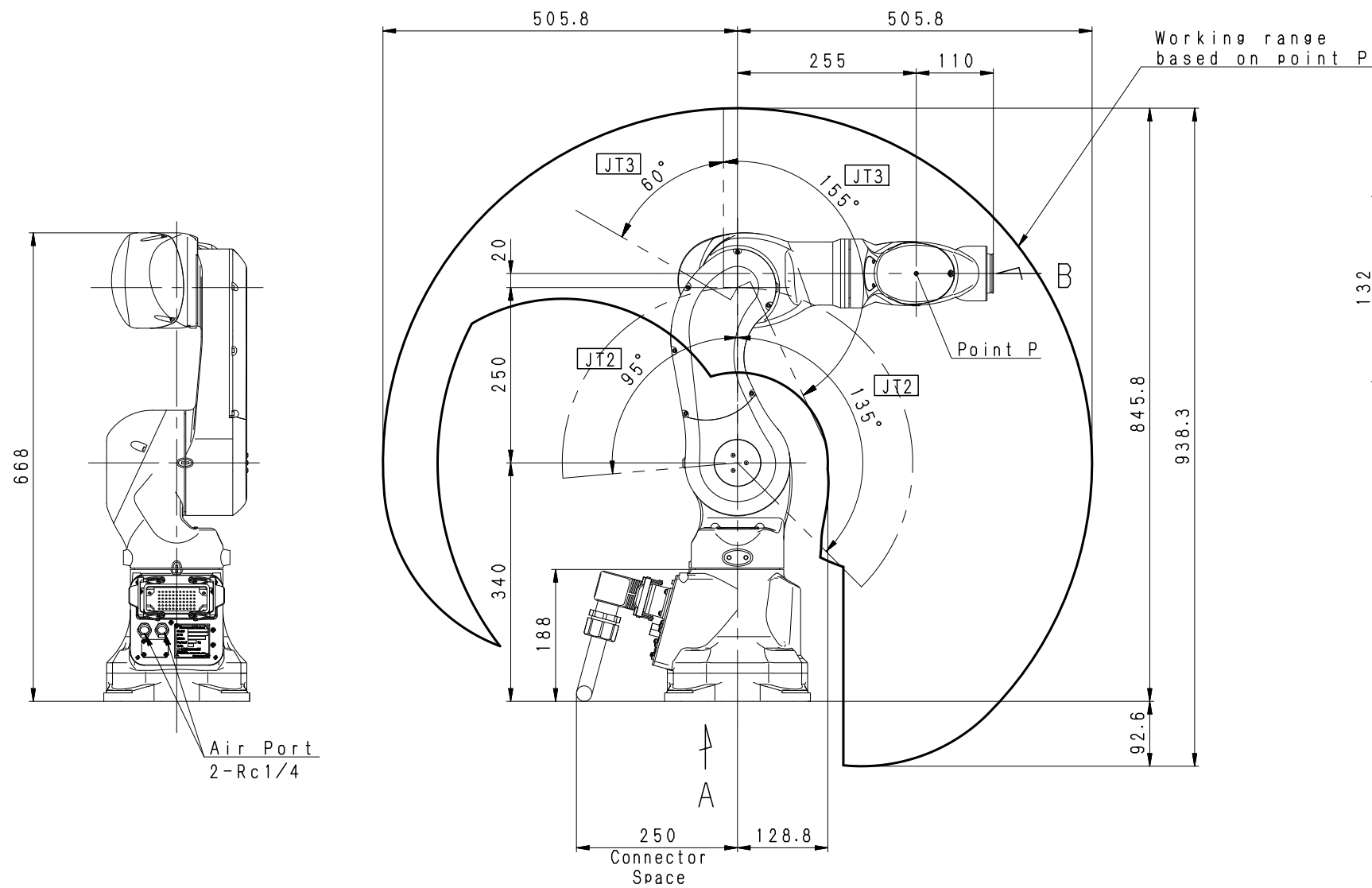
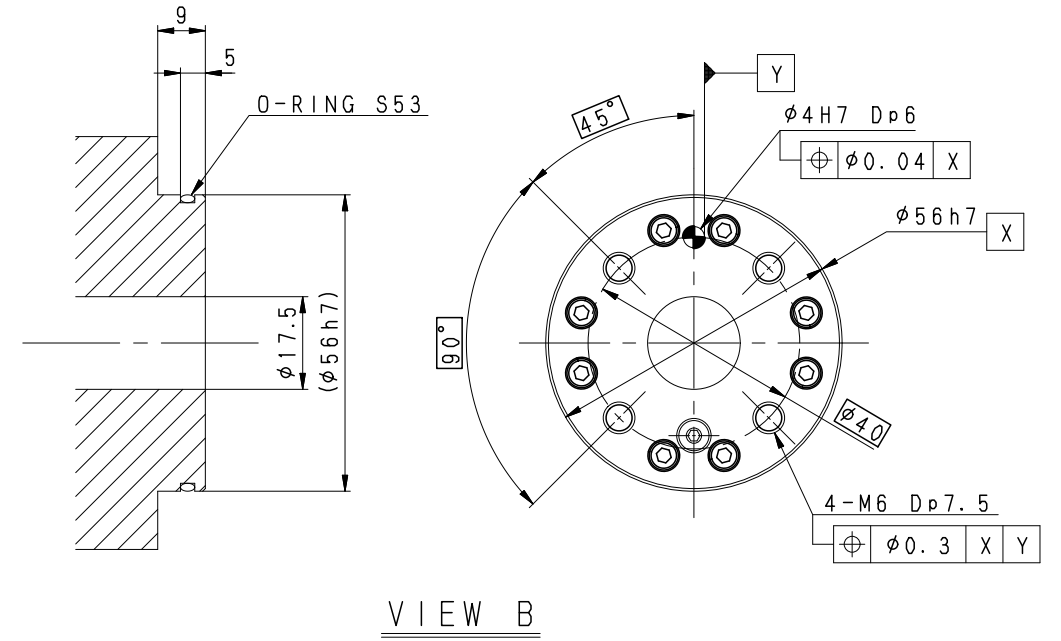
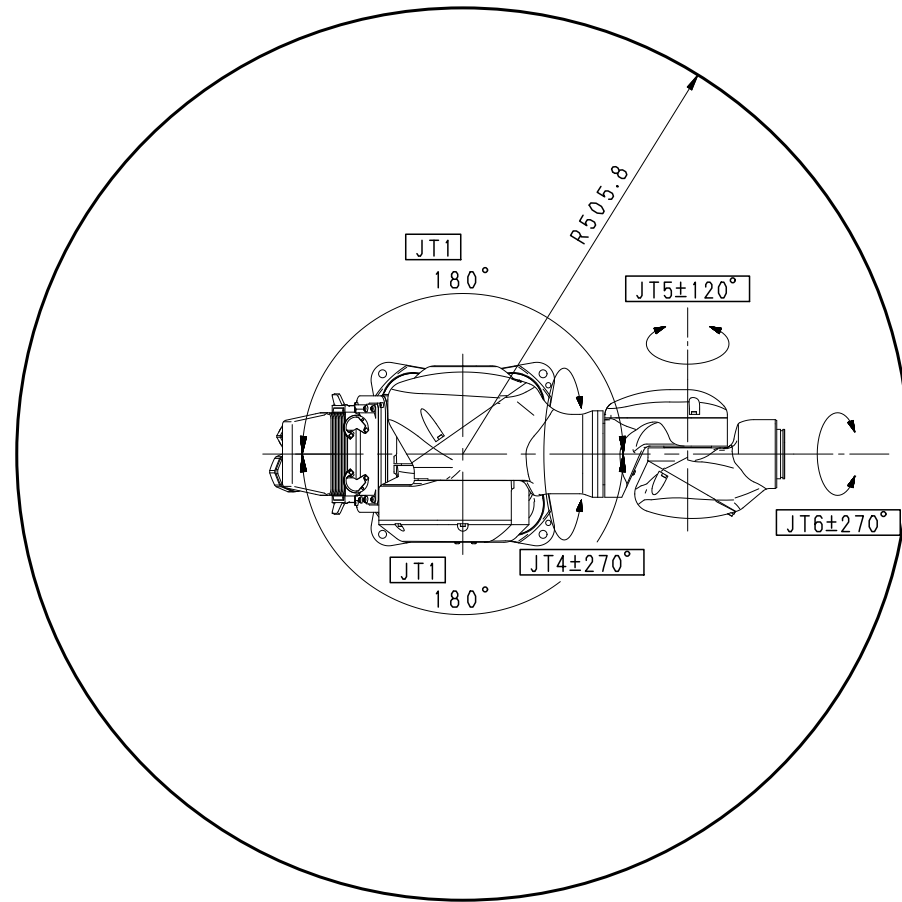

**MC004N
WORKING RANGE**

(Backside connector panel)