



Standard Specifications

KJ125J-B

1st ed. 30-May-19
4th ed. 21-Oct-25

Kawasaki Heavy Industries, Ltd.
Robot Business Division

Specification number : 90151-0270DED

Robot specifications

1. Model	KJ125J-B																						
2. Type	Articulated robot																						
3. Degree of freedom	6 axes																						
4. Max. payload	Wrist : 8 kg (at the tool mounting surface) Upper arm : 5 kg (including painting equipment in the pressurized chamber) Lower arm : 5 kg																						
5. Max. reach	1,299 mm																						
6. Position repeatability	±0.15 mm (wrist flange surface) conforms to ISO 9283																						
7. Max. painting speed	1,500 mm/s (at the center of tool mounting surface)																						
8. Axis specification	<table border="1"> <thead> <tr> <th colspan="2">Operating axis</th> <th>Motion range</th> </tr> </thead> <tbody> <tr> <td>Arm rotation</td> <td>(JT1)</td> <td>±160 °</td> </tr> <tr> <td>Arm out-in</td> <td>(JT2)</td> <td>+130 ° - -80 °</td> </tr> <tr> <td>Arm up-down</td> <td>(JT3)</td> <td>+90 ° - -75 °</td> </tr> <tr> <td>Wrist swivel</td> <td>(JT4)</td> <td>±720 °</td> </tr> <tr> <td>Wrist bend</td> <td>(JT5)</td> <td>±720 °</td> </tr> <tr> <td>Wrist twist</td> <td>(JT6)</td> <td>±410 °</td> </tr> </tbody> </table>		Operating axis		Motion range	Arm rotation	(JT1)	±160 °	Arm out-in	(JT2)	+130 ° - -80 °	Arm up-down	(JT3)	+90 ° - -75 °	Wrist swivel	(JT4)	±720 °	Wrist bend	(JT5)	±720 °	Wrist twist	(JT6)	±410 °
Operating axis		Motion range																					
Arm rotation	(JT1)	±160 °																					
Arm out-in	(JT2)	+130 ° - -80 °																					
Arm up-down	(JT3)	+90 ° - -75 °																					
Wrist swivel	(JT4)	±720 °																					
Wrist bend	(JT5)	±720 °																					
Wrist twist	(JT6)	±410 °																					
9. Load capacity of wrist	<table border="1"> <thead> <tr> <th></th> <th>Max. torque</th> <th>Moment of inertia*</th> </tr> </thead> <tbody> <tr> <td>JT4</td> <td>21.8 N·m</td> <td>0.90 kg·m²</td> </tr> <tr> <td>JT5</td> <td>17.0 N·m</td> <td>0.54 kg·m²</td> </tr> <tr> <td>JT6</td> <td>8.0 N·m</td> <td>0.12 kg·m²</td> </tr> </tbody> </table> <p>Note* Each value in this table shows allowable moment of inertia of JT4/JT5/JT6 when max. allowed torque is applied to each axis. If more detailed data is required for your application, please contact Kawasaki.</p>			Max. torque	Moment of inertia*	JT4	21.8 N·m	0.90 kg·m ²	JT5	17.0 N·m	0.54 kg·m ²	JT6	8.0 N·m	0.12 kg·m ²									
	Max. torque	Moment of inertia*																					
JT4	21.8 N·m	0.90 kg·m ²																					
JT5	17.0 N·m	0.54 kg·m ²																					
JT6	8.0 N·m	0.12 kg·m ²																					
10. Mass	190 kg (without options)																						
11. Mounting	Floor or Wall or Ceiling mounting																						
12. Installation Environment	Ambient Temperature: 0 - 40 °C																						
	Relative Humidity: 35 - 85 % (with no dew condensation)																						
13. Color	Munsell 10GY9/1 equivalent																						
14. Explosion proof	Pressurized and intrinsically safe																						
15. Air supply to the manipulator	Clean & dry air	0.5 Nm ³ /min, 0.4 - 0.7 MPa																					
	Dew point	-17 °C or less at atmospheric pressure																					
	Solid material	0.01 μm or less																					
	Oil content	Mist separation 99.9999% or more																					
16. Options	Mechanical stopper	Adjustable stoppers JT1/JT2/JT3																					
	Painting equipment	Solenoid valve for painting (up to 1 units can be equipped with)																					

Consult Kawasaki about maintenance parts and spare parts.

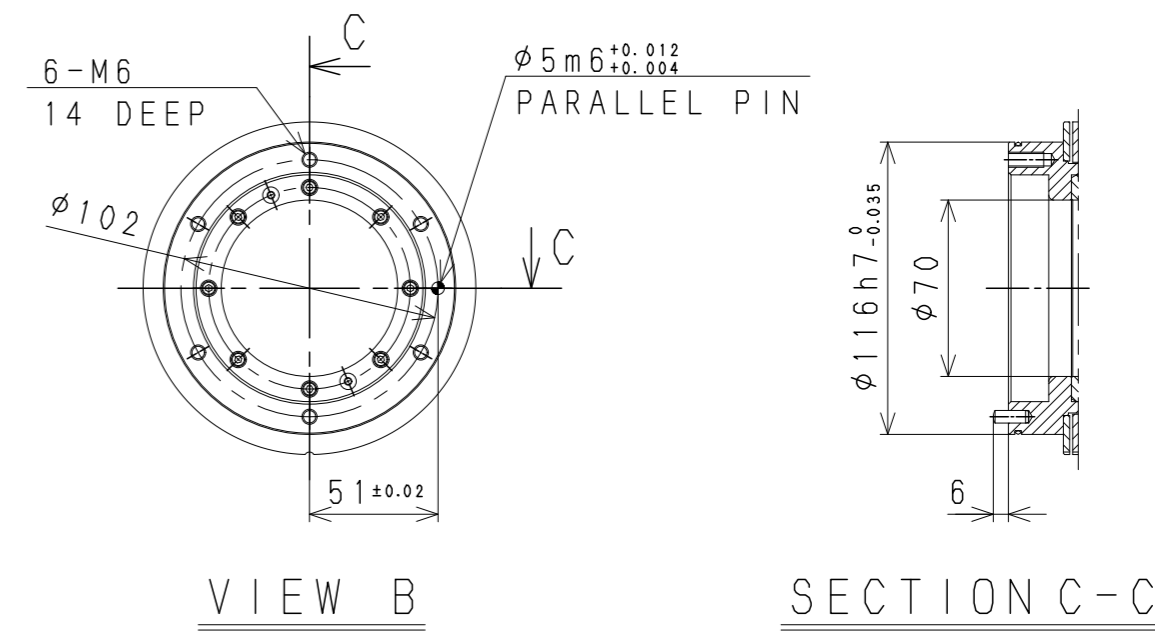
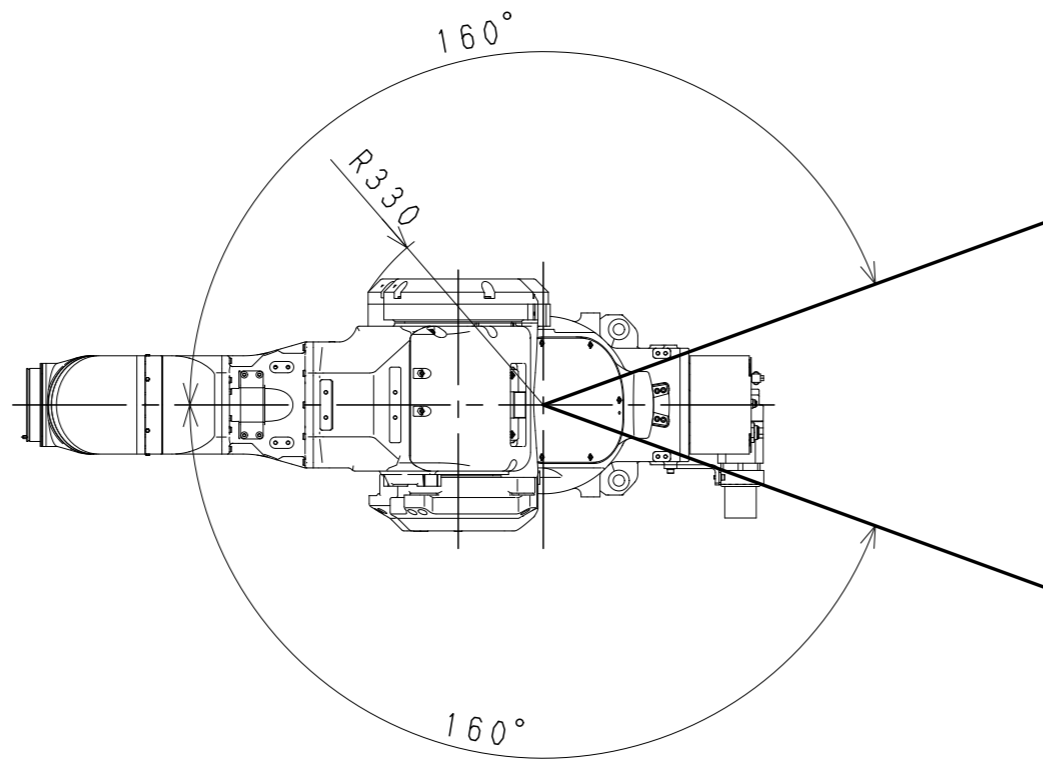

Working range based on point P

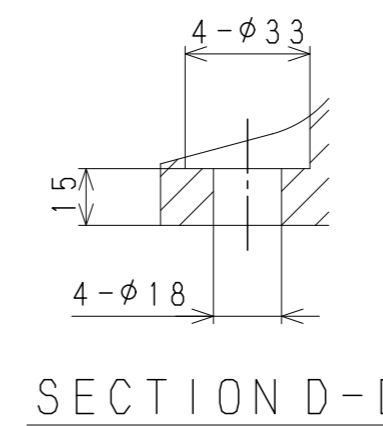
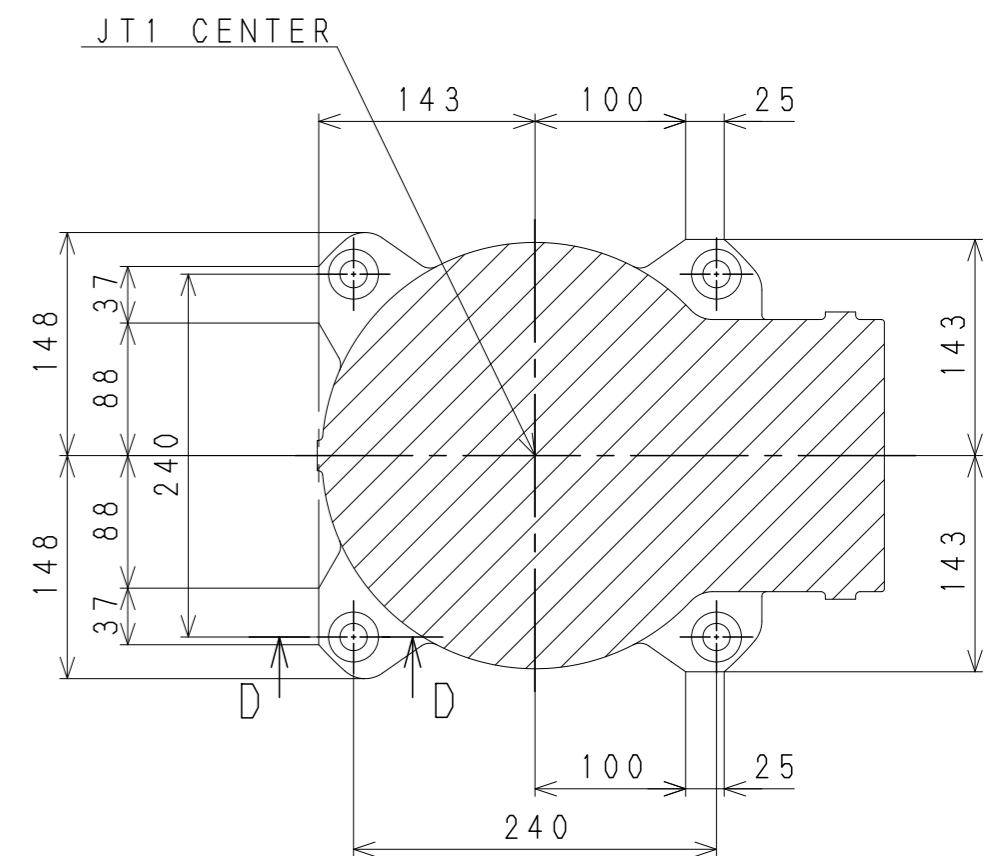
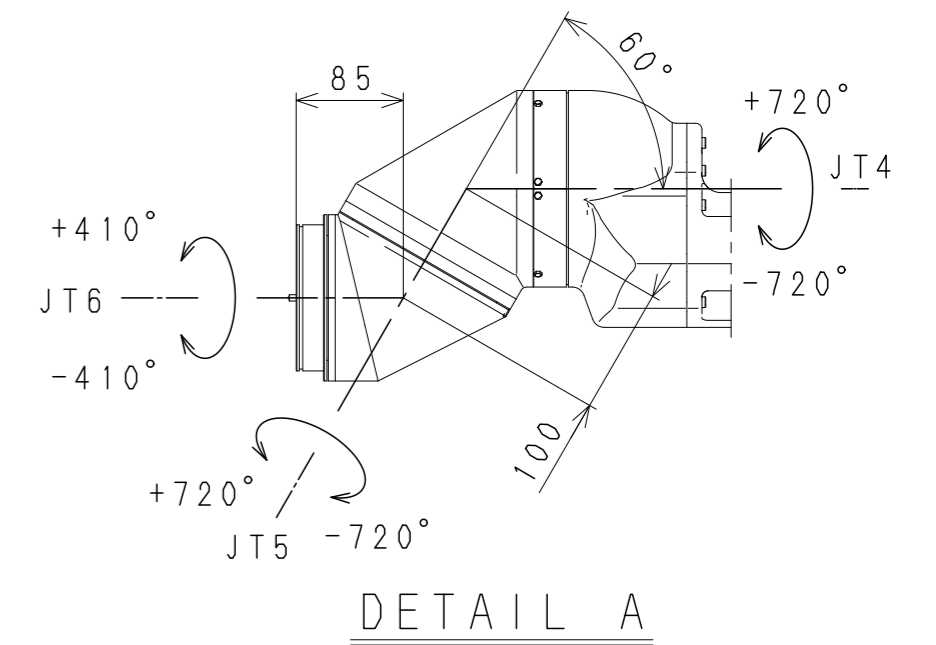
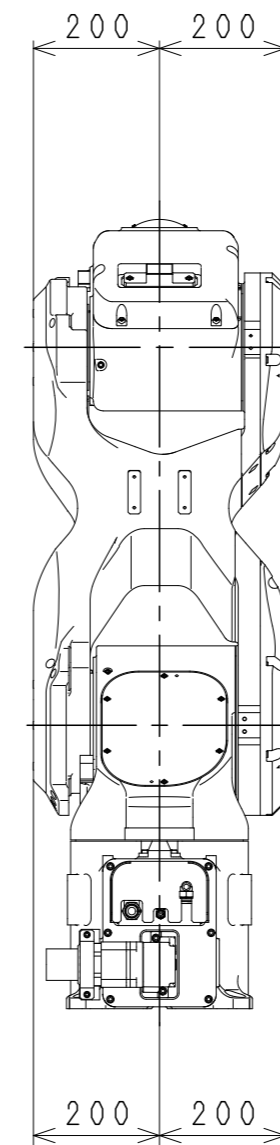
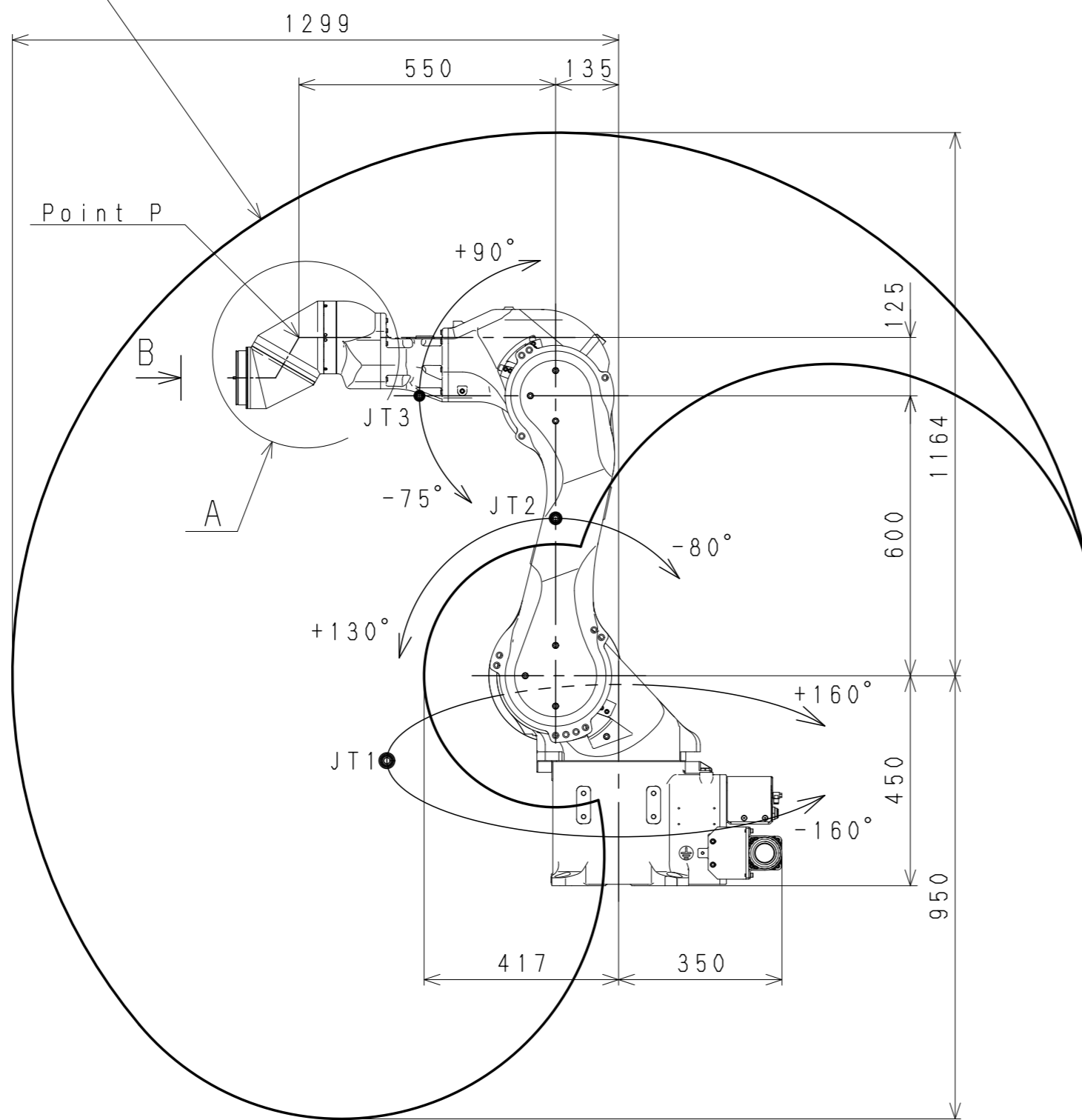
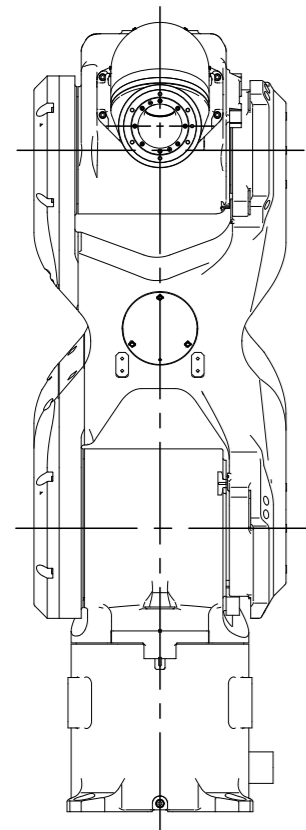

KJ125J-B
WORKING RANGE

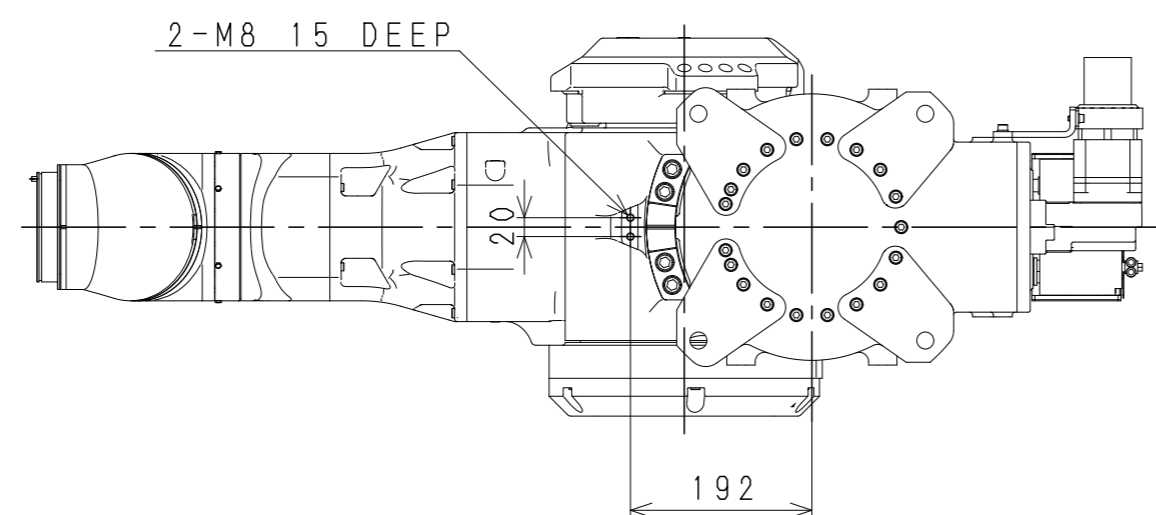
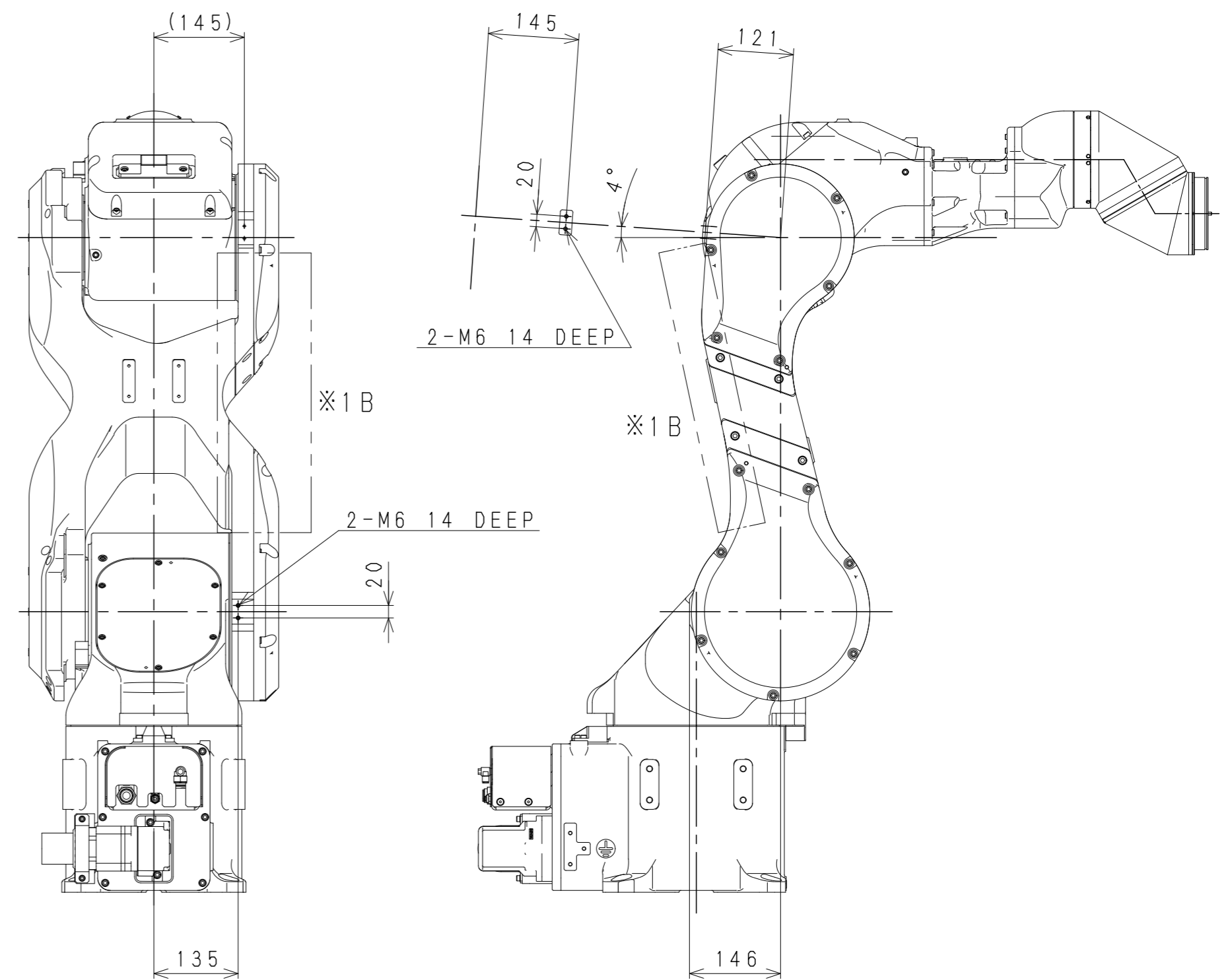
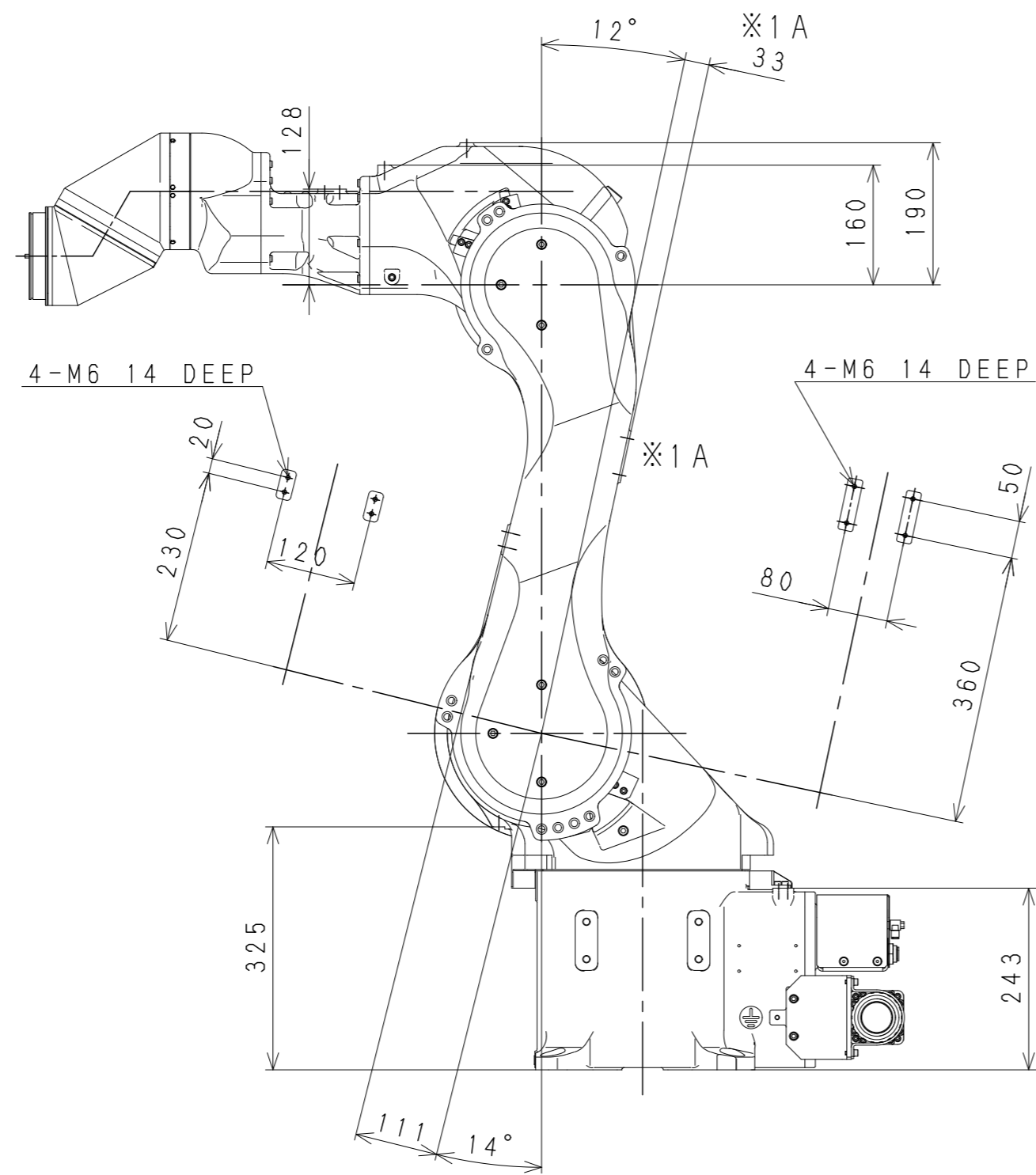
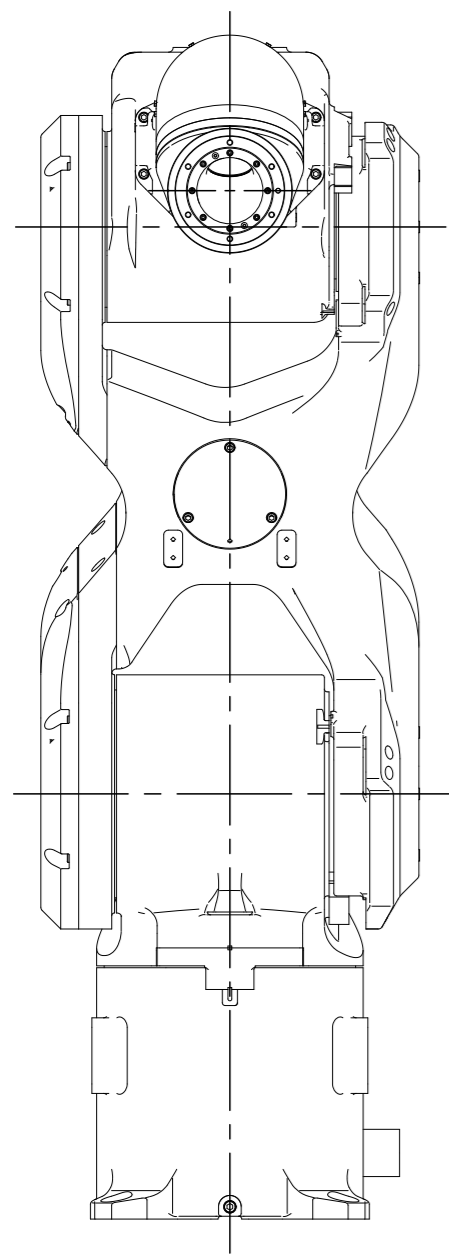
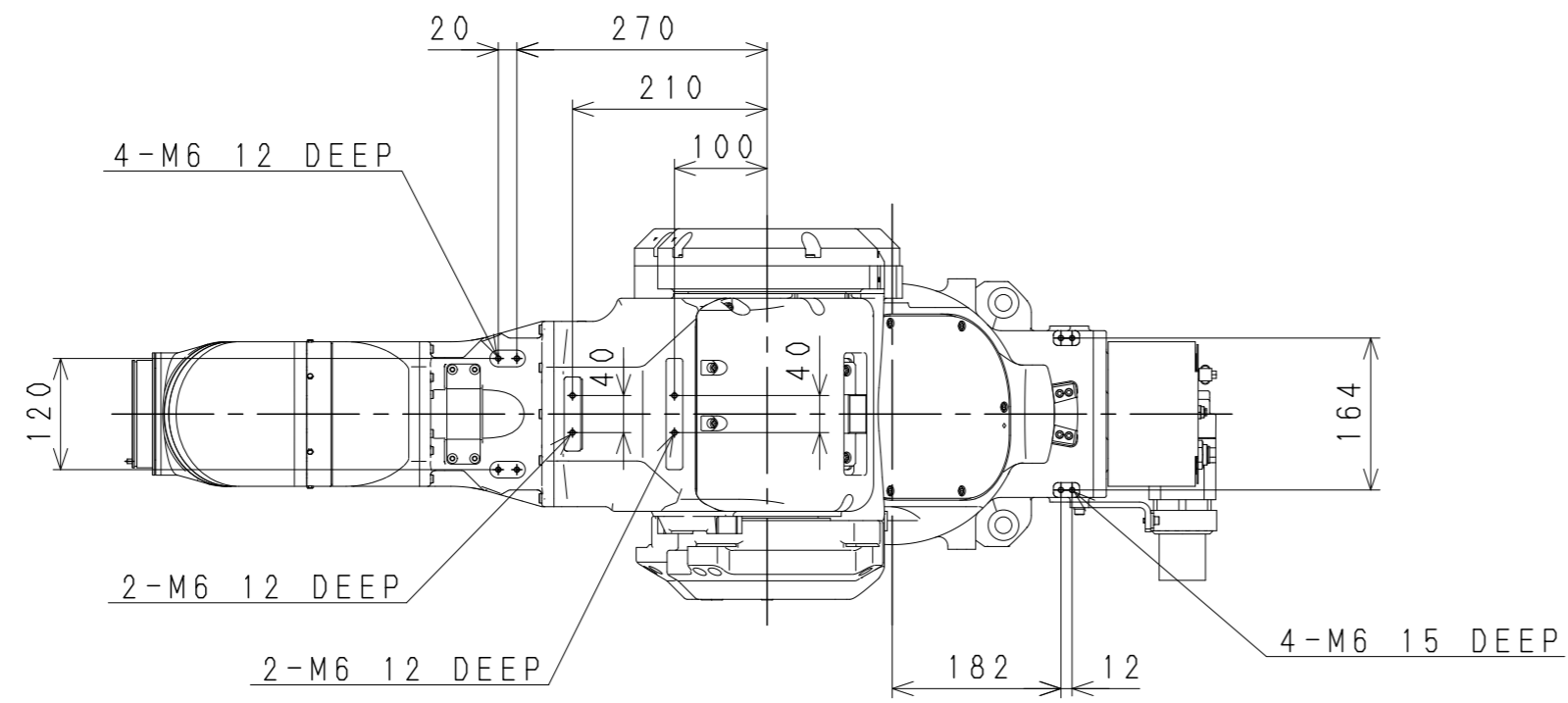

※1
 ※1 Bは部品の接合部であり、実機と上図の外形にズレが生じることがあります。
 ※1 Aに固定するブラケットが、※1 Bの近くに位置する場合は、ブラケットと
 ※1 Bの間に十分なクリアランスを設けてください。

Near by ※1B, there may be a gap between the actual shape
 and drawing shape.
 When you fix a bracket near ※1B, please provide enough
 clearance between the bracket and ※1B.

KJ125J-B
 SERVICE TAP LOCATION