

EXPLOSION PROOF PAINTING ROBOTS

K Series

Kawasaki Heavy Industries, Ltd.

Robot Business Division

Tokyo Head Office/Robot Division
1-14-5, Kaigan, Minato-ku, Tokyo 105-8315, Japan
Phone: +81-3-3435-2501 Fax: +81-3-3437-9880

Akashi Works/Robot Division
1-1, Kawasaki-cho, Akashi, Hyogo 673-8666, Japan
Phone: +81-78-921-2946 Fax: +81-78-923-6548

Nishi-Kobe Works/Robot Division
234, Matsumoto, Hasetani-cho, Nishi-ku, Kobe, Hyogo
651-2239, Japan
Phone: +81-78-915-8136 Fax: +81-78-915-8274

Kawasaki Robotics website
<https://kawasakirobotics.com/>



Kawasaki Robostage (showroom)
<https://kawasakirobotics.com/jp-sp/robostage/en/>



Global Network

Kawasaki Robotics (USA), Inc.
28140 Lakeview Drive, Wixom, MI 48393, U.S.A.
Phone: +1-248-446-4100 Fax: +1-248-446-4200

Kawasaki Robotics (UK) Ltd.
Unit 4 Easter Court, Europa Boulevard, Westbrook
Warrington Cheshire, WA5 7ZB, United Kingdom
Phone: +44-1925-71-3000 Fax: +44-1925-71-3001

Kawasaki Robotics GmbH
Im Taubental 32, 41468 Neuss, Germany
Phone: +49-2131-34260 Fax: +49-2131-3426-22

Kawasaki Robotics Korea, Ltd.
Room 1408, 135, Gasan digital 2-ro, Geumcheon-gu, Seoul,
Republic of Korea
Phone: +82-32-821-6941 Fax: +82-32-821-6947

Kawasaki Robotics (Tianjin) Co., Ltd.
1-2/F, Building 6, No.19 Xinhuan Road, TEDA, China
Phone: +86-22-5983-1888 Fax: +86-22-5983-1889

Taiwan Kawasaki Robot Center
3F, No.31, Ln.216, Gongyuan Rd., Hsinchu City
30069, Taiwan(R.O.C)
Phone: +886-3-562-0518

Kawasaki Robotics (Thailand) Co., Ltd.
(Rayong Robot Center)
119/9 Moo 4 T.Pluak Daeng, A.Pluak Daeng, Rayong 21140
Thailand
Phone: +66-38-955-040-58 Fax: +66-38-955-145

Singapore Kawasaki Robot Center
100G Pasir Panjang Road #06-10
Singapore 118523
Phone: +65-6513-3145

Kawasaki Robotics India Pvt. Ltd.
1/5, Village-Khandsa, Khasra No. 1364,599/2/2/1,
Hero Honda Chowk,Gurgaon-122001, Haryana
Phone: +91-124-608-5500

* Materials and specifications are subject to change without notice.



CAUTIONS TO BE TAKEN TO ENSURE SAFETY

- For any persons involved with the operation / servicing of your system, including Kawasaki Robot, they must strictly observe all safety regulations at all times. Please carefully read the Manuals and other related safety documents.
- Products described in this catalogue are general industrial robots. Therefore, if a customer wishes to use the Robot for special purposes, which might endanger operators, or if the Robot has any problems, please contact us. We will be happy to help you.
- Please be careful as Photographs illustrated in this catalogue are frequently taken after the removal of safety fences and other safety devices stipulated in the safety regulations from the Robot operation system.



Explosion-proof Painting Robots

Kawasaki offers explosion-proof painting robots with a world-leading market share, featuring a versatile lineup that automates painting processes for everything from small parts to large components.

K series

K

- F** With an extremely compact wrist, the robot flexibly handles painting in narrow inner panel areas. It excels at simple repetitive motions, making teaching easy and efficient.
- J** A lightweight and slim painting robot that allows flexible layout planning in any installation configuration. Its hollow wrist enables internal routing of tubes and cables.
- L** An explosion-proof, heavy-duty robot with no restrictions on workpiece position or movement. Boasting a maximum payload of 45 kg—the largest in the K series.



Features

- Full lineup of painting robots cover diverse workpieces from small to large.
- The 3R type hollow wrist can install hoses inside to prevent dusts on the painted parts.
- Painting package cells support users to introduce robot painting lines with ease (optional).

Variations of wrists

RBR
KF121

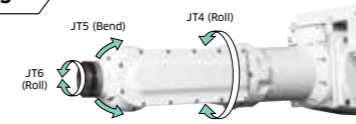

BBR
KF192 / KF262 / KL262

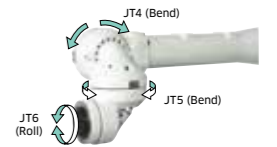

3R(Ø50mm*)
KJ125 / KJ155

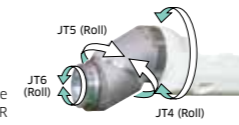

3R(Ø70mm)
KJ194 / KJ244 / KJ264
KJ314

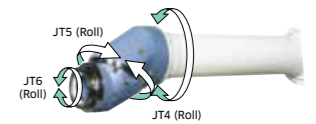

*The shape of the tool mounting part of the wrist (flange surface) is same as that of the 3R (Ø70mm)

		KF series			KJ series					KL series	
		KF121	KF192	KF262	KJ125	KJ155	KJ194 (Floor)	KJ244 (Floor)	KJ264 (Floor)	KJ314 (Wall)	KL262 (Floor)
Degree of freedom (axes)		6			6					7	6
Wrist type		RBR	BBR		3R(Ø50mm)*5	3R(Ø50mm)*5	3R(Ø70mm)			BBR	
Motion range(*)	Arm rotation (JT1)	±160/±60	±150		±160	±160	±120			±120	
	Arm out-in (JT2)	±90	+110 - -60							+130 - -80	+130 - -80
	Arm up-down (JT3)	±150	+90 - -80		+90 - -75	+90 - -75	+90 - -65			+90 - -65	
	Wrist swivel (JT4)	±270	±360							±720	±360
	Wrist bend (JT5)	±145	±360							±720	±360
	Wrist twist (JT6)	±360	±360							±410	±360
	Arm swing (JT7)	-	-							-	±90
Painting speed (m/s)		1.5	2		1.5					1.6	
Position repeatability*2 (mm)		±0.2	±0.5		±0.5	±0.5	±0.5			±0.5	
Max. reach*1 (mm)		1,240	1,973	2,665	1,299	1,545	1,940	2,490	2,640	3,100	2,640
Payload (kg)		5	Wrist : 12 Arm : 20		Wrist : 8 Arm : 5	Wrist : 8 Arm : 5	Wrist : 15 Arm : 25			Wrist : 45	
Wrist Torque (N·m)	JT4	7.8	33.3		21.8	21.8	56.2			260	
	JT5	7.8	28.8		17	17	43.4			260	
	JT6	2.9	7.9		8	8	22			120	
Wrist Moment (kg·m)	JT4	0.17	1.28	1.2	0.9	0.9	2.19			15.6	
	JT5	0.17	0.96	0.9	0.54	0.54	1.31			15.6	
	JT6	0.06	0.1	0.11	0.12	0.12	0.33			3.3	
Mass (kg)		140	690	720	190	195	530	540		720	600
Mounting		Floor, wall, ceiling*4	Floor, wall		Floor, wall, ceiling	Floor, wall, ceiling	Floor, Shelf, wall			wall	Floor, Shelf
Explosionproof construction	America	Combination of pressurized and intrinsically safe (CL I ZN 1 AEx ib pxb IIB T4 / AEx ib IIB T4 Gb)		Combination of pressurized and intrinsically safe (CL I ZN 1 AEx ib pxb IIB T4 / AEx ib IIB T4 Gb)							
	Canada	Combination of pressurized and intrinsically safe (Ex ib pxb IIB T4 Gb / Ex ib IIB T4 Gb)		Combination of pressurized and intrinsically safe (Ex ib pxb IIB T4 Gb / Ex ib IIB T4 Gb)							
	Europe	Combination of pressurized and intrinsically safe (II2 G Ex pxb ib IIB T4 / Ex ib IIB T4 Gb)				Combination of pressurized and intrinsically safe (II2 G Ex pxb ib IIB T4 / Ex ib IIB T4 Gb)					
	Korea	Combination of pressurized and intrinsically safe (Ex ib px IIB T4 / Ex ib IIB T4)					Please contact us.		Combination of pressurized and intrinsically safe (fG4 / Ex ib IIB T4)		
	China	Combination of pressurized and intrinsically safe (Ex ib px IIB T4 Gb / Ex ib IIB T4 Gb)				Combination of pressurized and intrinsically safe (Ex ib px IIB T4 Gb / Ex ib IIB T4 Gb)					
	Japan & Asia (except China & Korea)	Combination of pressurized and intrinsically safe (Expxib IIB T4 / Ex ib IIB T4 Gb)				Combination of pressurized and intrinsically safe (Expxib IIB T4 / Ex ib IIB T4 Gb)					
Temperature (°C)		0~40°C									
Color		Munsell 10GY9/1 equivalent									
Power requirements*3 (kVA)		1.5	5		3	3	5			-	
Controller	America, Canada	E37, F35	-							E35, F35	-
	Europe	E47, F45	E45, F45	E45, F45						E45, F45	-
	Japan & Asia	E27, F25	E25, F25	E25, F25						E25, F25	E25, F25 (Japan)

*Specifications are based on floor-mounted configuration (KJ314 is wall-mounted only). *1: RBR: Distance between centers of JT1 and JT5. 3R: Distance from JT1 center to the intersection of JT4 and JT5 rotation axes. *2: Conforms to ISO9283. *3: Depends on payload and motion patterns. *4: For U.S. and Canada, only floor-mounted and wall-mounted configurations are available. *5: The tool mounting section at the wrist flange end has the same shape as 3R (Ø70 mm).

BBR: Distance from JT1 center to the intersection of JT4 rotation axis. *2: Conforms to ISO9283. *3: Depends on payload and motion patterns.

Painting of Small Parts

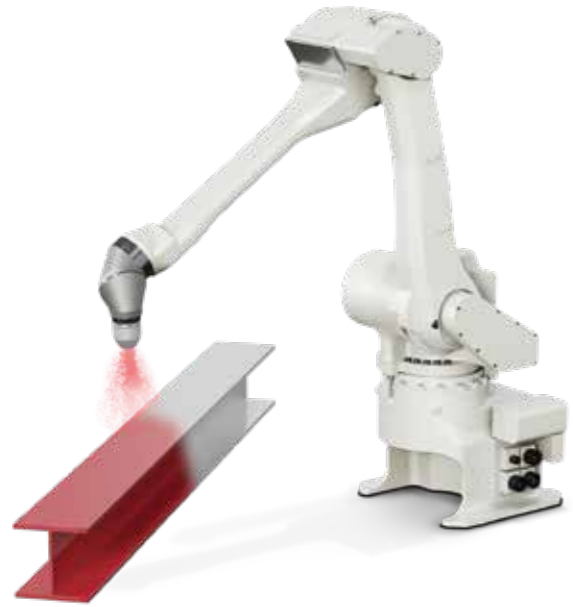

Precision-painted small parts for high-quality finishes

Painting of Moving Workpieces



Stably paints workpieces with movement and realizes efficient work

Small sized painting applications

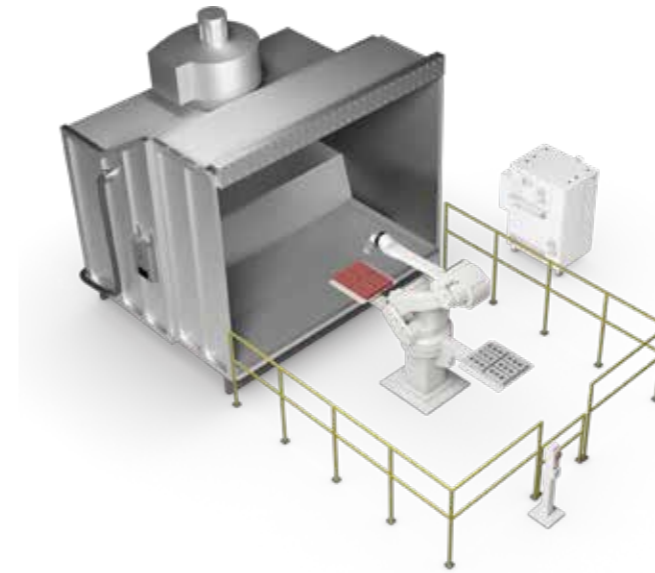

Servo Tombow P13
 Servo Tombow-R P14
 Servo Twister P15

Medium sized work-piece painting cell

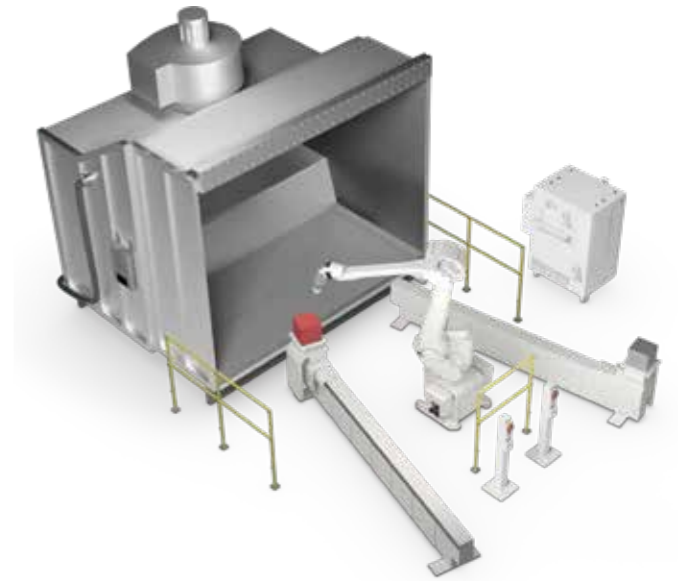

Servo Shuttle P16
 Servo Wing P17
 Servo Spinner P18

Painting of Workpieces with Various Shapes



Uniformly paints workpieces with complex shapes and provides a beautiful finish

Remote-Controlled Painting

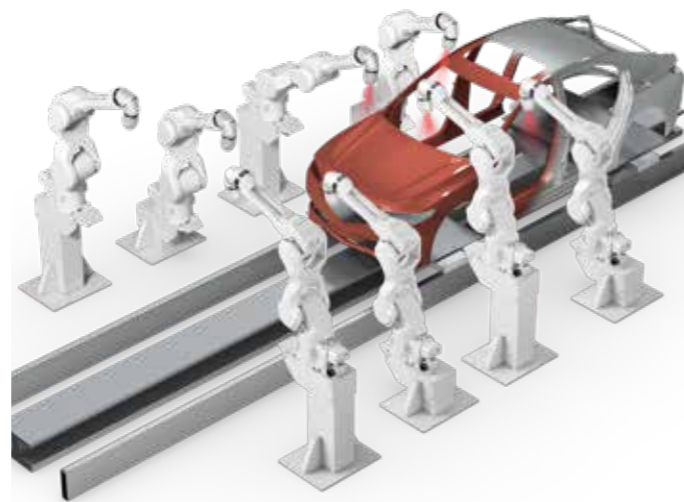

Efficient and high-precision coating with multiple machines for a wide working range and consistent quality

Large sized work-piece painting cell

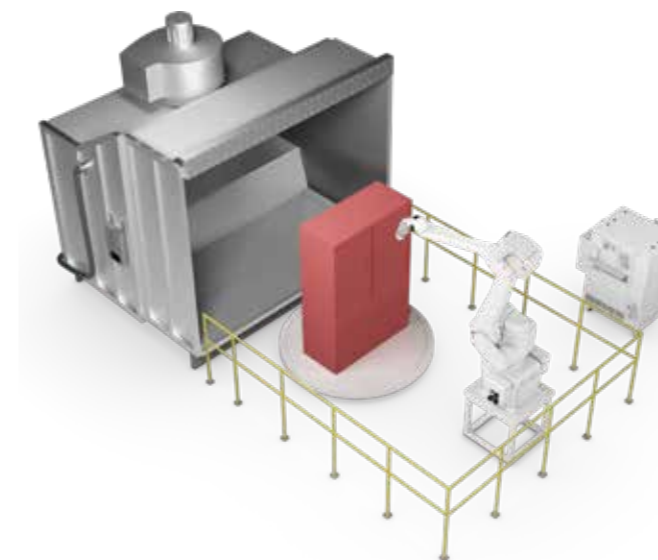

Servo Turntable P18

Tilt Spinner

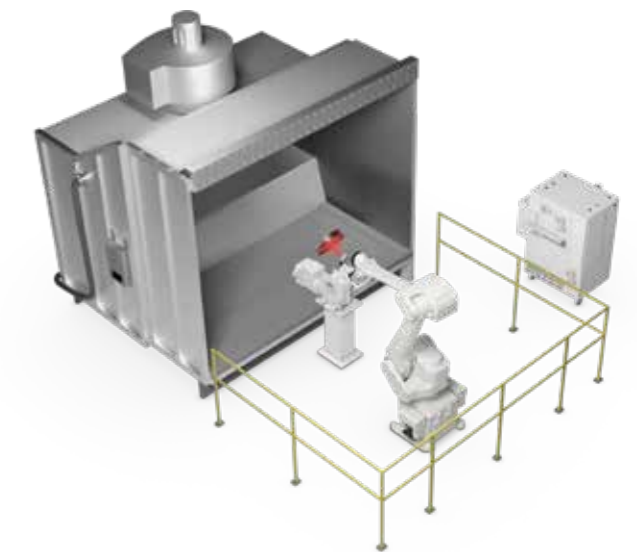

Tilt Spinner P19

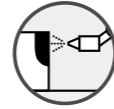

KF121

Standard Specifications

Type	Articulated robot	
Degree of freedom (axes)	6	
Payload (kg)	5	
Max. reach*1 (mm)	1,240	
Position repeatability*2 (mm)	±0.2	
Motion range (°)	Arm rotation (JT1)	±160/±60 (Wall)
	Arm out-in (JT2)	±90
	Arm up-down (JT3)	±150
	Wrist swivel (JT4)	±270
	Wrist bend (JT5)	±145
	Wrist twist (JT6)	±360
Mass (kg)	140	
Mounting	Floor, wall, ceiling*4	
Power requirements*3 (kVA)	1.5	
Explosion-proof construction	America	Combination of pressurized and intrinsically safe (CL I ZN 1 AEx ib pxb IIB T4 / AEx ib IIB T4 Gb)
	Canada	Combination of pressurized and intrinsically safe (Ex ib pxb IIB T4 Gb / Ex ib IIB T4 Gb)
	Europe	Combination of pressurized and intrinsically safe (II 2 G Ex pxb ib IIB T4 / Ex ib IIB T4 Gb)
	Korea	Combination of pressurized and intrinsically safe (Ex ib pxb IIB T4 Gb / Ex ib IIB T4)
	China	Combination of pressurized and intrinsically safe (Ex ib px IIB T4 Gb / Ex ib IIB T4 Gb)
	Japan & Asia (except China & Korea)	Combination of pressurized and intrinsically safe (Expixib IIB T4 / Ex ib IIB T4 Gb)
Controller	America, Canada	E37, F35
	Europe	E47, F45
	Japan & Asia	E27, F25

*1: Distance between centers of JT1 and JT5.
 *2: Conforms to ISO9283.
 *3: Depends on payload and motion patterns.
 *4: For America and Canada, only floor and wall mount types are available.

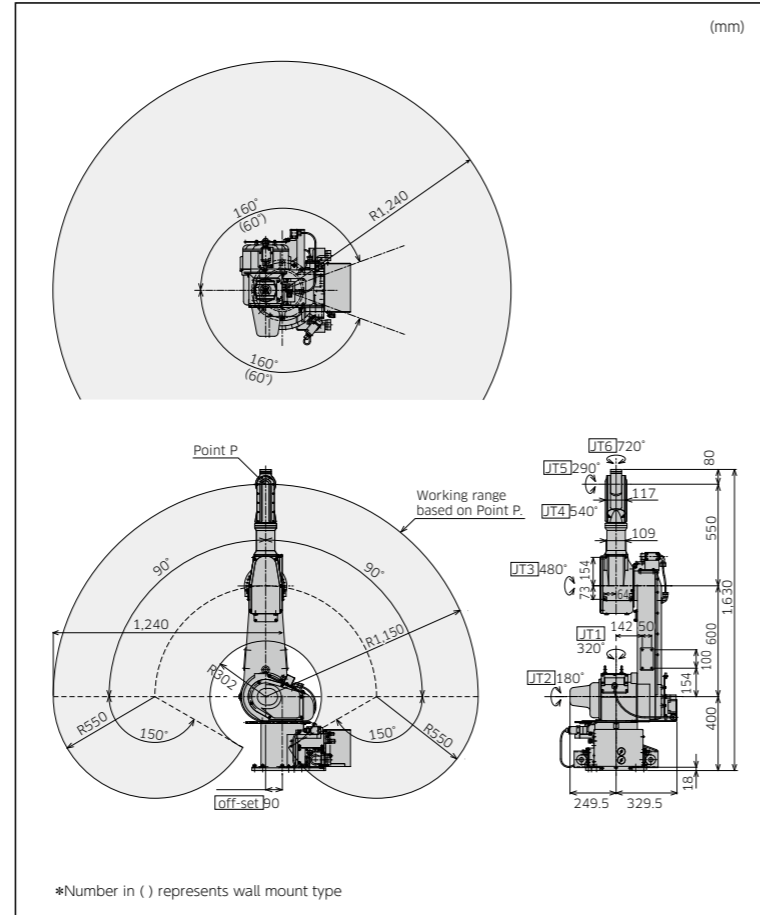

*Number in () represents wall mount type

KF262

Standard Specifications

Type	Articulated robot	
Degree of freedom (axes)	6	
Payload (kg)	Wrist : 12 Arm : 20	
Max. reach*1 (mm)	2,665	
Position repeatability*2 (mm)	±0.5	
Motion range (°)	Arm rotation (JT1)	±150
	Arm out-in (JT2)	+110 - -60
	Arm up-down (JT3)	+90 - -80
	Wrist swivel (JT4)	±360
	Wrist bend (JT5)	±360
	Wrist twist (JT6)	±360
Painting speed (m/s)	1.2	
Mass (kg)	720	
Mounting	Floor, wall	
Power requirements*3 (kVA)	5	
Explosion-proof construction	Europe	Combination of pressurized and intrinsically safe (II 2 G Ex pxb ib IIB T4 / Ex ib IIB T4 Gb)
	Korea	Combination of pressurized and intrinsically safe (Ex ib pxb IIB T4 Gb / Ex ib IIB T4)
	China	Combination of pressurized and intrinsically safe (Ex ib px IIB T4 Gb / Ex ib IIB T4 Gb)
	Japan & Asia (except China & Korea)	Combination of pressurized and intrinsically safe (Expixib IIB T4 / Ex ib IIB T4 Gb)
	Europe	E45, F45
Controller	Japan & Asia	E25, F25

*1: Distance between centers of JT1 and JT4.
 *2: Conforms to ISO9283.
 *3: Depends on payload and motion patterns.

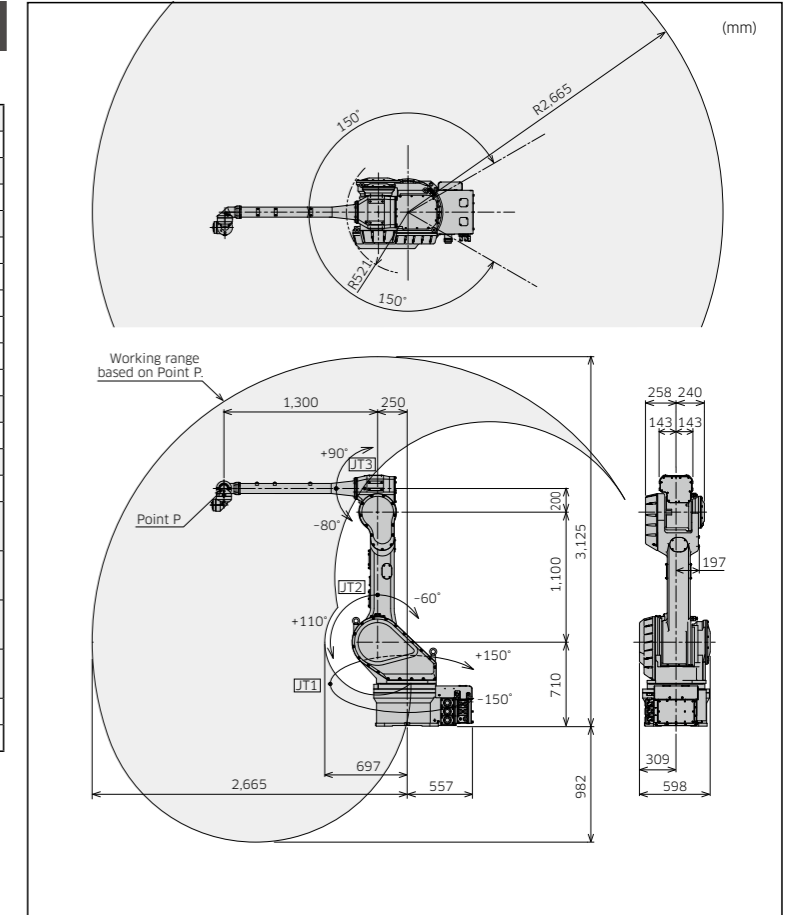

KF192

Standard Specifications

Type	Articulated robot	
Degree of freedom (axes)	6	
Payload (kg)	Wrist : 12 Arm : 20	
Max. reach*1 (mm)	1,973	
Position repeatability*2 (mm)	±0.5	
Motion range (°)	Arm rotation (JT1)	±150
	Arm out-in (JT2)	+110 - -60
	Arm up-down (JT3)	+90 - -80
	Wrist swivel (JT4)	±360
	Wrist bend (JT5)	±360
	Wrist twist (JT6)	±360
Painting speed (m/s)	1.2	
Mass (kg)	690	
Mounting	Floor, wall	
Power requirements*3 (kVA)	5	
Explosion-proof construction	Europe	Combination of pressurized and intrinsically safe (II 2 G Ex pxb ib IIB T4 / Ex ib IIB T4 Gb)
	Korea	Combination of pressurized and intrinsically safe (Ex ib pxb IIB T4 Gb / Ex ib IIB T4)
	China	Combination of pressurized and intrinsically safe (Ex ib px IIB T4 Gb / Ex ib IIB T4 Gb)
	Japan & Asia (except China & Korea)	Combination of pressurized and intrinsically safe (Expixib IIB T4 / Ex ib IIB T4 Gb)
	Europe	E45, F45
Controller	Japan & Asia	E25, F25

*1: Distance between centers of JT1 and JT4.
 *2: Conforms to ISO9283.
 *3: Depends on payload and motion patterns.

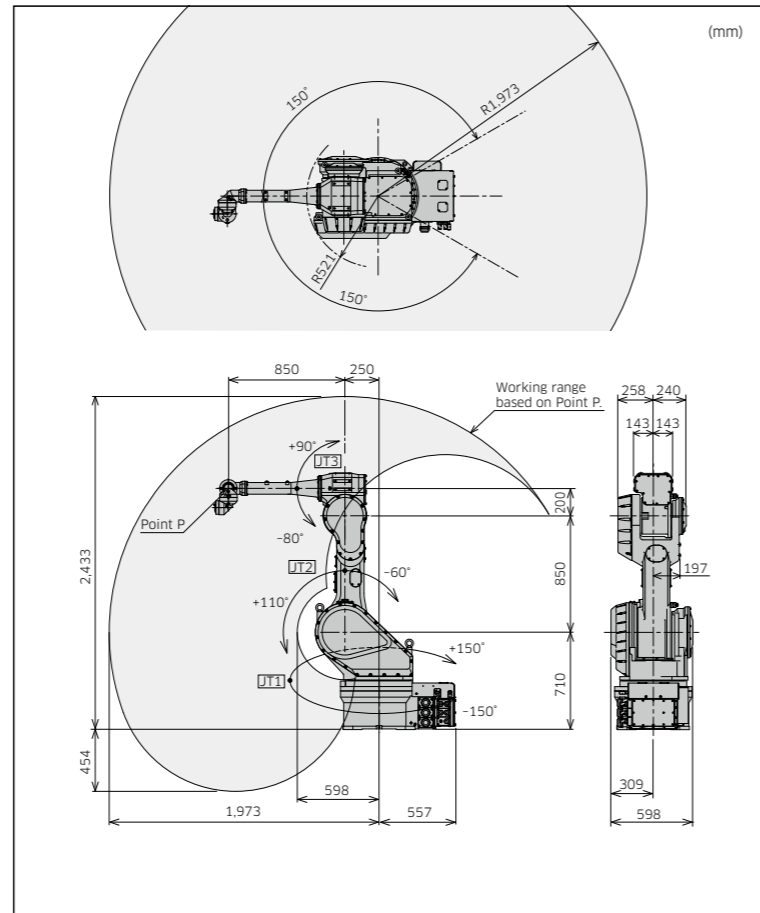

KJ125

Standard Specifications

Type	Articulated robot	
Degree of freedom (axes)	6	
Payload (kg)	Wrist : 8 Arm : 5	
Max. reach*1 (mm)	1,299	
Position repeatability*2 (mm)	±0.15	
Motion range (°)	Arm rotation (JT1)	±160
	Arm out-in (JT2)	+130 - -80
	Arm up-down (JT3)	+90 - -75
	Wrist swivel (JT4)	±720
	Wrist bend (JT5)	±720
	Wrist twist (JT6)	±410
Painting speed (m/s)	1.5	
Mass (kg)	190	
Mounting	Floor, wall	
Power requirements*3 (kVA)	3	
Explosion-proof construction	America	Combination of pressurized and intrinsically safe (CL I ZN 1 AEx ib pxb IIB T4 / AEx ib IIB T4 Gb)
	Canada	Combination of pressurized and intrinsically safe (Ex ib pxb IIB T4 Gb / Ex ib IIB T4 Gb)
	Europe	Combination of pressurized and intrinsically safe (II 2 G Ex pxb ib IIB T4 / Ex ib IIB T4 Gb)
	Korea	Combination of pressurized and intrinsically safe (Ex ib pxb IIB T4 Gb / Ex ib IIB T4)
	China	Combination of pressurized and intrinsically safe (Ex ib px IIB T4 Gb / Ex ib IIB T4 Gb)
	Japan & Asia (except China & Korea)	Combination of pressurized and intrinsically safe (FG4 / Ex ib IIB T4 Gb)
Controller	America, Canada	E35, F35
	Europe	E45, F45
	Japan & Asia	E25, F25

*1: Distance between centers of JT1 and JT5.
 *2: Conforms to ISO9283.
 *3: Depends on payload and motion patterns.

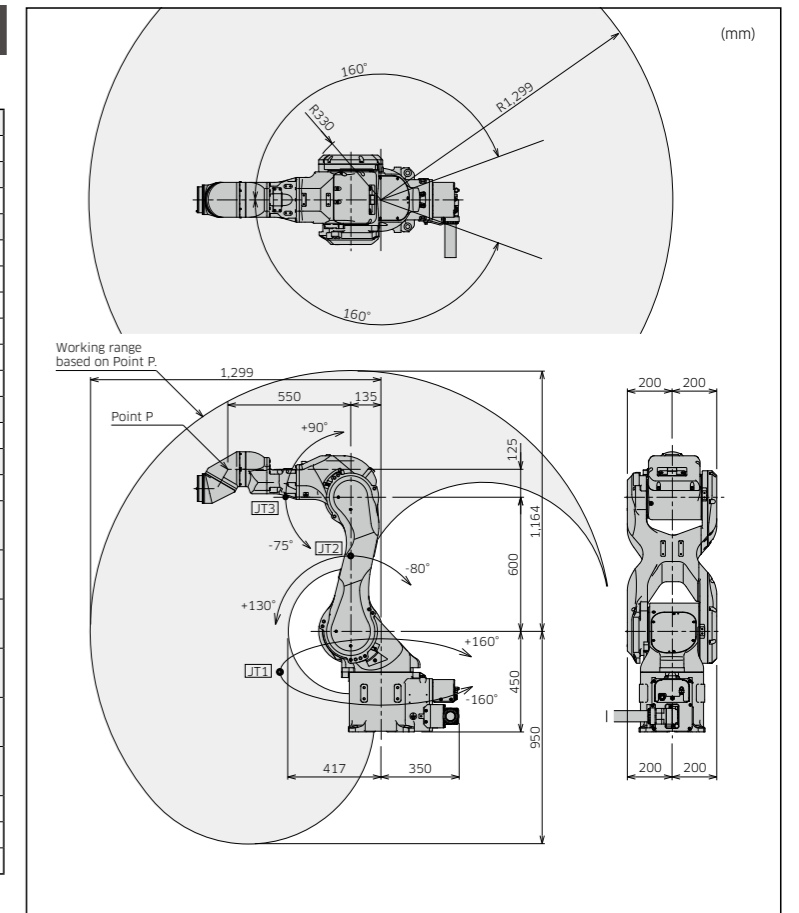

KJ155

Standard Specifications

Type	Articulated robot	
Degree of freedom (axes)	6	
Payload (kg)	Wrist : 8 Arm : 5	
Max. reach*1 (mm)	1,545	
Position repeatability*2 (mm)	±0.15	
Motion range (°)	Arm rotation (JT1)	±160
	Arm out-in (JT2)	+130 - -80
	Arm up-down (JT3)	+90 - -75
	Wrist swivel (JT4)	±720
	Wrist bend (JT5)	±720
	Wrist twist (JT6)	±410
Painting speed (m/s)	1.5	
Mass (kg)	195	
Mounting	Floor, wall	
Power requirements*3 (kVA)	3	
Explosion-proof construction	America	Combination of pressurized and intrinsically safe (CL I ZN 1 AEx ib pxb IIB T4 / AEx ib IIB T4 Gb)
	Canada	Combination of pressurized and intrinsically safe (Ex ib pxb IIB T4 Gb / Ex ib IIB T4 Gb)
	Europe	Combination of pressurized and intrinsically safe (II G Ex pxb ib IIB T4 / Ex ib IIB T4 Gb)
	Korea	Combination of pressurized and intrinsically safe (Ex ib pxb IIB T4 Gb / Ex ib IIB T4)
	China	Combination of pressurized and intrinsically safe (Ex ib px IIB T4 Gb / Ex ib IIB T4 Gb)
	Japan & Asia (except China & Korea)	Combination of pressurized and intrinsically safe (FG4 / Ex ib IIB T4 Gb)
Controller	America, Canada	E35, F35
	Europe	E45, F45
	Japan & Asia	E25, F25

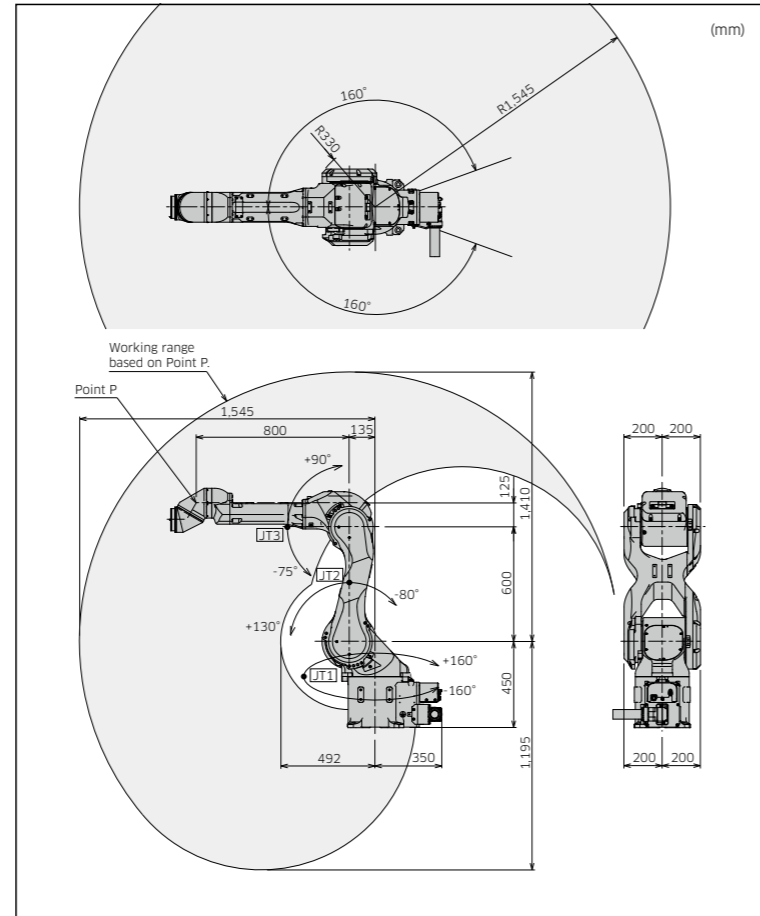

*1: Distance between centers of JT1 and JT5.
*2: Conforms to ISO9283.
*3: Depends on payload and motion patterns.

KJ244(Floor)

Standard Specifications

Type	Articulated robot	
Degree of freedom (axes)	6	
Payload (kg)	Wrist : 15 Arm : 25	
Max. reach*1 (mm)	2,490	
Position repeatability*2 (mm)	±0.5	
Motion range (°)	Arm rotation (JT1)	±120
	Arm out-in (JT2)	+130 - -80
	Arm up-down (JT3)	+90 - -65
	Wrist swivel (JT4)	±720
	Wrist bend (JT5)	±720
	Wrist twist (JT6)	±410
Painting speed (m/s)	1.5	
Mass (kg)	540	
Mounting	Floor	
Power requirements*3 (kVA)	5	
Explosion-proof construction	America	Combination of pressurized and intrinsically safe (CL I ZN 1 AEx ib pxb IIB T4 / AEx ib IIB T4 Gb)
	Canada	Combination of pressurized and intrinsically safe (Ex ib pxb IIB T4 Gb / Ex ib IIB T4 Gb)
	Europe	Combination of pressurized and intrinsically safe (II G Ex pxb ib IIB T4 / Ex ib IIB T4 Gb)
	Korea	Combination of pressurized and intrinsically safe (Ex ib pxb IIB T4 Gb / Ex ib IIB T4)
	China	Combination of pressurized and intrinsically safe (Ex ib px IIB T4 Gb / Ex ib IIB T4 Gb)
	China	Combination of pressurized and intrinsically safe (FG4 / Ex ib IIB T4 Gb)
Controller	America, Canada	E35, F35
	Europe	E45, F45
	Japan & Asia	E25, F25

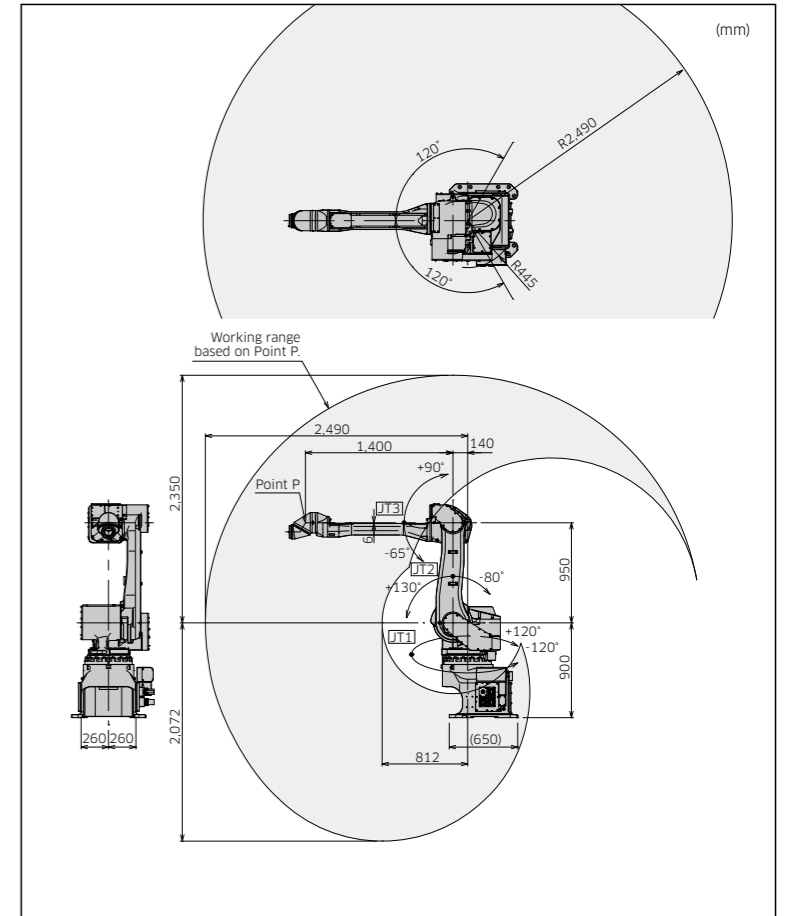

*1: Distance between centers of JT1 and JT5.
*2: Conforms to ISO9283.
*3: Depends on payload and motion patterns.

KJ194(Floor)

Standard Specifications

Type	Articulated robot	
Degree of freedom (axes)	6	
Payload (kg)	Wrist : 15 Arm : 25	
Max. reach*1 (mm)	1,940	
Position repeatability*2 (mm)	±0.5	
Motion range (°)	Arm rotation (JT1)	±120
	Arm out-in (JT2)	+130 - -80
	Arm up-down (JT3)	+90 - -65
	Wrist swivel (JT4)	±720
	Wrist bend (JT5)	±720
	Wrist twist (JT6)	±410
Painting speed (m/s)	1.5	
Mass (kg)	530	
Mounting	Floor	
Power requirements*3 (kVA)	5	
Explosion-proof construction	America	Combination of pressurized and intrinsically safe (CL I ZN 1 AEx ib pxb IIB T4 / AEx ib IIB T4 Gb)
	Canada	Combination of pressurized and intrinsically safe (Ex ib pxb IIB T4 Gb / Ex ib IIB T4 Gb)
	Europe	Combination of pressurized and intrinsically safe (II G Ex pxb ib IIB T4 / Ex ib IIB T4 Gb)
	Korea	Combination of pressurized and intrinsically safe (Ex ib pxb IIB T4 Gb / Ex ib IIB T4)
	China	Combination of pressurized and intrinsically safe (Ex ib px IIB T4 Gb / Ex ib IIB T4 Gb)
	Japan & Asia (except China & Korea)	Combination of pressurized and intrinsically safe (FG4 / Ex ib IIB T4 Gb)
Controller	America, Canada	E35, F35
	Europe	E45, F45
	Japan & Asia	E25, F25

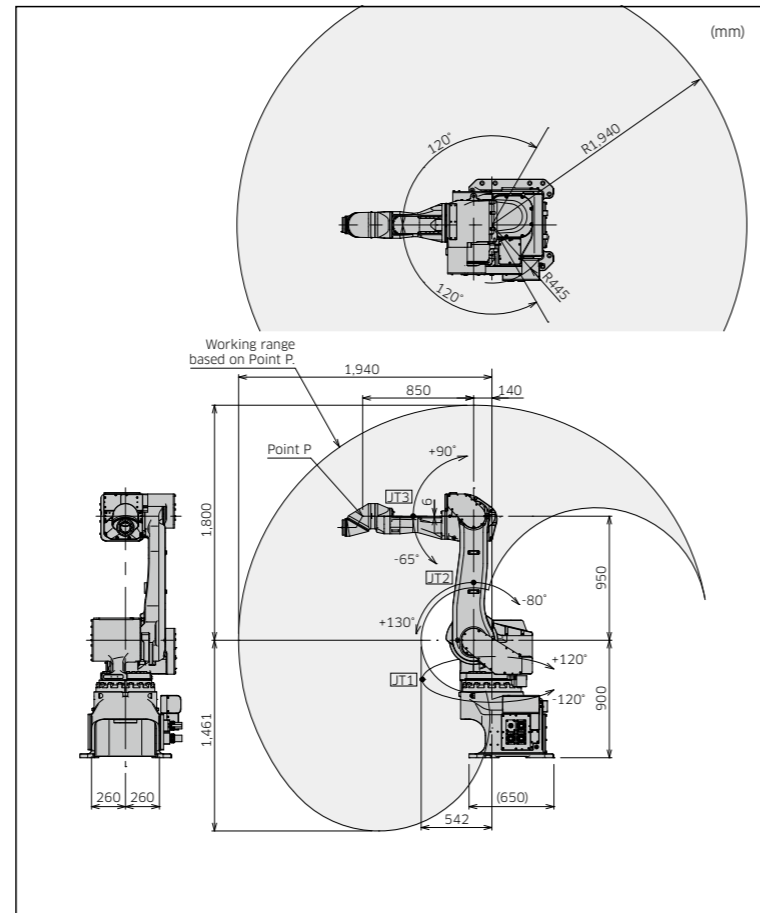

*1: Distance between centers of JT1 and JT5.
*2: Conforms to ISO9283.
*3: Depends on payload and motion patterns.

KJ264(Floor)

Standard Specifications

Type	Articulated robot	
Degree of freedom (axes)	6	
Payload (kg)	Wrist : 15 Arm : 25	
Max. reach*1 (mm)	2,640	
Position repeatability*2 (mm)	±0.5	
Motion range (°)	Arm rotation (JT1)	±120
	Arm out-in (JT2)	+130 - -80
	Arm up-down (JT3)	+90 - -65
	Wrist swivel (JT4)	±720
	Wrist bend (JT5)	±720
	Wrist twist (JT6)	±410
Painting speed (m/s)	1.5	
Mass (kg)	540	
Mounting	Floor	
Power requirements*3 (kVA)	5	
Explosion-proof construction	America	Combination of pressurized and intrinsically safe (CL I ZN 1 AEx ib pxb IIB T4 / AEx ib IIB T4 Gb)
	Canada	Combination of pressurized and intrinsically safe (Ex ib pxb IIB T4 Gb / Ex ib IIB T4 Gb)
	Europe	Combination of pressurized and intrinsically safe (II G Ex pxb ib IIB T4 / Ex ib IIB T4 Gb)
	Korea	Combination of pressurized and intrinsically safe (Ex ib pxb IIB T4 Gb / Ex ib IIB T4)
	China	Combination of pressurized and intrinsically safe (Ex ib px IIB T4 Gb / Ex ib IIB T4 Gb)
	China	Combination of pressurized and intrinsically safe (FG4 / Ex ib IIB T4 Gb)
Controller	America, Canada	E35, F35
	Europe	E45, F45
	Japan & Asia	E25, F25

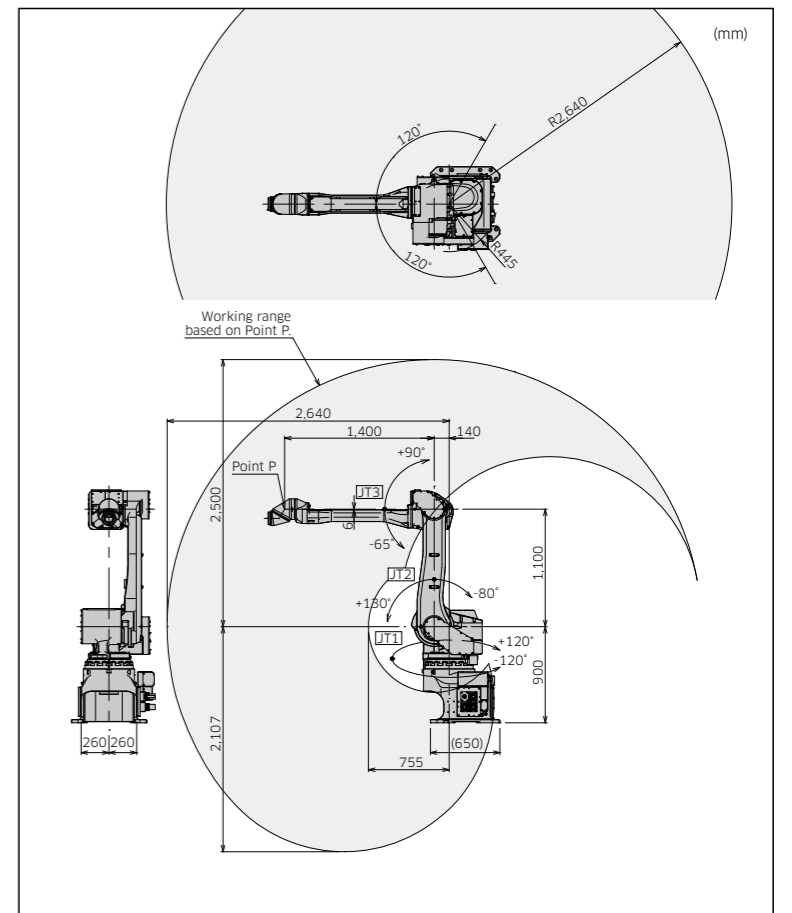

*1: Distance between centers of JT1 and JT5.
*2: Conforms to ISO9283.
*3: Depends on payload and motion patterns.

KJ314 (Wall)

Standard Specifications

Type	Articulated robot	
Degree of freedom (axes)	7	
Payload (kg)	Wrist : 15 Arm : 25	
Max. reach*1 (mm)	3,100	
Position repeatability*2 (mm)	±0.5	
Motion range (°)	Arm rotation (JT1)	±120
	Arm out-in (JT2)	+130 - -80
	Arm up-down (JT3)	+90 - -65
	Wrist swivel (JT4)	±720
	Wrist bend (JT5)	±720
	Wrist twist (JT6)	±410
	Arm swing (JT7)	±90
Painting speed (m/s)	1.5	
Mass (kg)	720	
Mounting	Wall	
Power requirements*3 (kVA)	5	
Explosion-proof construction	America	Combination of pressurized and intrinsically safe (CL I ZN 1 AEx ib pxb IIB T4 / AEx ib IIB T4 Gb)
	Canada	Combination of pressurized and intrinsically safe (Ex ib pxb IIB T4 Gb / Ex ib IIB T4 Gb)
	Europe	Combination of pressurized and intrinsically safe (II2 G Ex pxb ib IIB T4 / Ex ib IIB T4 Gb)
	Korea	Combination of pressurized and intrinsically safe (Ex ib pxb IIB T4 Gb / Ex ib IIB T4)
	China	Combination of pressurized and intrinsically safe (Ex ib px IIB T4 Gb / Ex ib IIB T4 Gb)
Controller	America, Canada	E35, F35
	Europe	E45, F45
	Japan & Asia	E25, F25

*1: Distance between centers of JT1 and JT5.
*2: Conforms to ISO9283.
*3: Depends on payload and motion patterns.

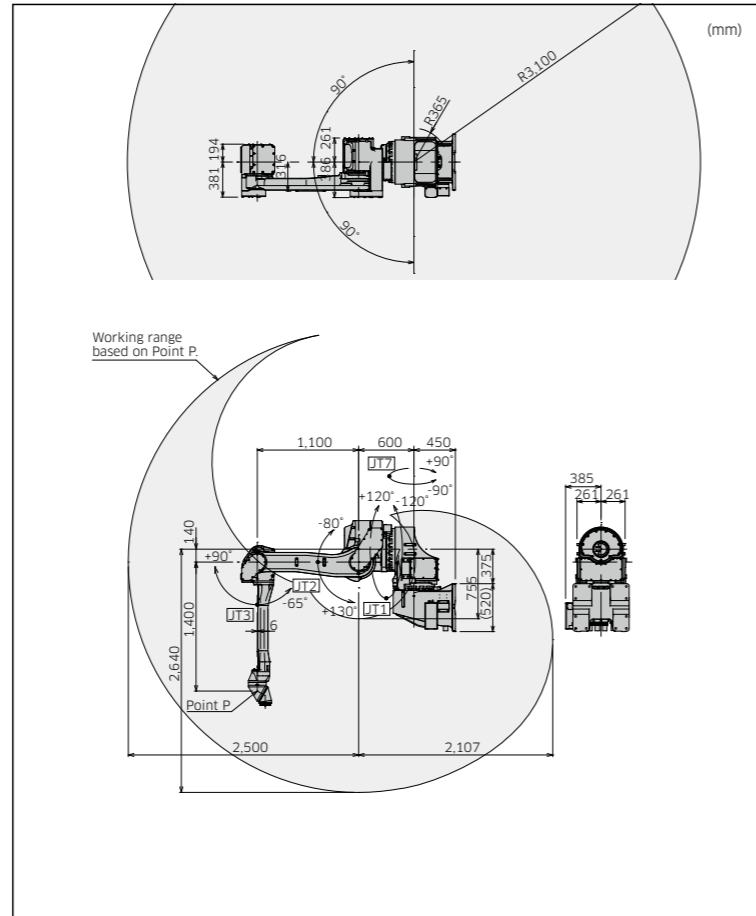

KL262

Standard Specifications

Type	Articulated robot	
Degree of freedom (axes)	6	
Payload (kg)	Wrist : 45	
Max. reach*1 (mm)	2,640	
Position repeatability*2 (mm)	Wrist flange surface: ±0.5	
Motion range (°)	Arm rotation (JT1)	±120
	Arm out-in (JT2)	+130 - -80
	Arm up-down (JT3)	+90 - -65
	Wrist swivel (JT4)	±360
	Wrist bend (JT5)	±360
	Wrist twist (JT6)	±360
Painting speed (m/s)	1.6	
Mass (kg)	600	
Mounting	Floor	
Power requirements*3 (kVA)	5	
Explosion-proof construction	Japan	Combination of pressurized and intrinsically safe (FG4)
	Japan	E25, F25

*1: Distance between centers of JT1 and JT5.
*2: Conforms to ISO9283.
*3: Depends on payload and motion patterns.

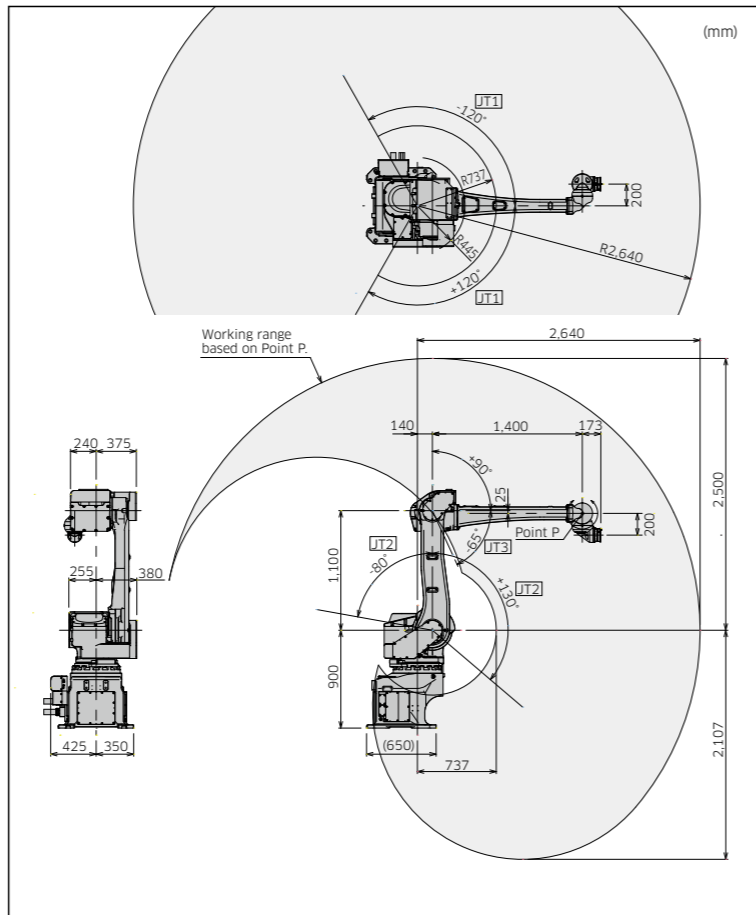

E25, E35, E45/E27, E37, E47

Features

- Space saving thanks to the small footprint.
- By installing additional amplifiers, a conveyor, a gear pump and up to 3 external axes can be used.

Standard Specifications

America & Canada	E35	E37
Europe	E45	E47
Japan & Asia	E25	E27
Dimensions (mm)	W500×D550×H1,400	
Construction	Enclosed structure/Indirect cooling system	
Controlled (axes)	6 (Max. 9)	
Memory capacity (MB)	8	
I/O signals	External operation	Motor power Off, Hold
	Input (Channels)	32
	Output (Channels)	32
Cable length	Robot-controller (m)	3 (Inside the booth, outside the booth)
	Teach pendant (m)	10
Mass (kg)	120 (E25/E27), 170 (E35/E37, E45/E47)	
Power requirements	E35/E37	AC440-480V ±10%, 60 Hz, 3ø 7.3kVA (E35)/5.1kVA (E37)*1 Protective ground, leakage current: 10 mA at maximum
	E45/E47	AC380-415V ±10%, 50/60 Hz, 3ø 7.3kVA (E45)/5.1kVA (E47)*1 Protective ground, leakage current: 10 mA at maximum
	E25/E27	AC200-220V ±10%, 50/60Hz, 3ø 10kVA (E25)/5.6kVA (E27)*1 Class-D ground (standard for robots), leakage current: 100 mA at maximum Class-A ground (for intrinsic explosion-proof safety circuits)
Installation environment	Ambient temperature (°C)	0 - 45
	Relative humidity (%)	35 - 85 (No dew, nor frost allowed)
Teach pendant	TFT color LCD display with touch-panel, E-Stop switch, teach lock switch, Enable switch	
Operation panel	E-stop switch, teach/repeat switch*2, control power light (Cycle start, motor-on, hold/run, and error rest are activated from the teach pendant.)	

*1: Power requirements ensure maximum operation of a robot, not those required for normal operations.
*2: The E45/E47 comes with three switches to change between teach/teach 100%/repeat, as standard equipment.



External view and dimensions

E25, E35, E45 / E27, E37, E47

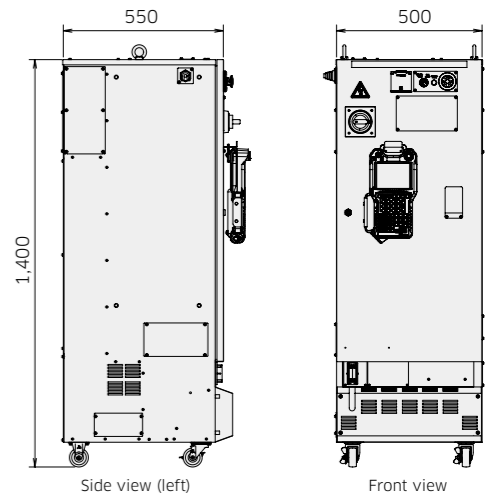

System configuration

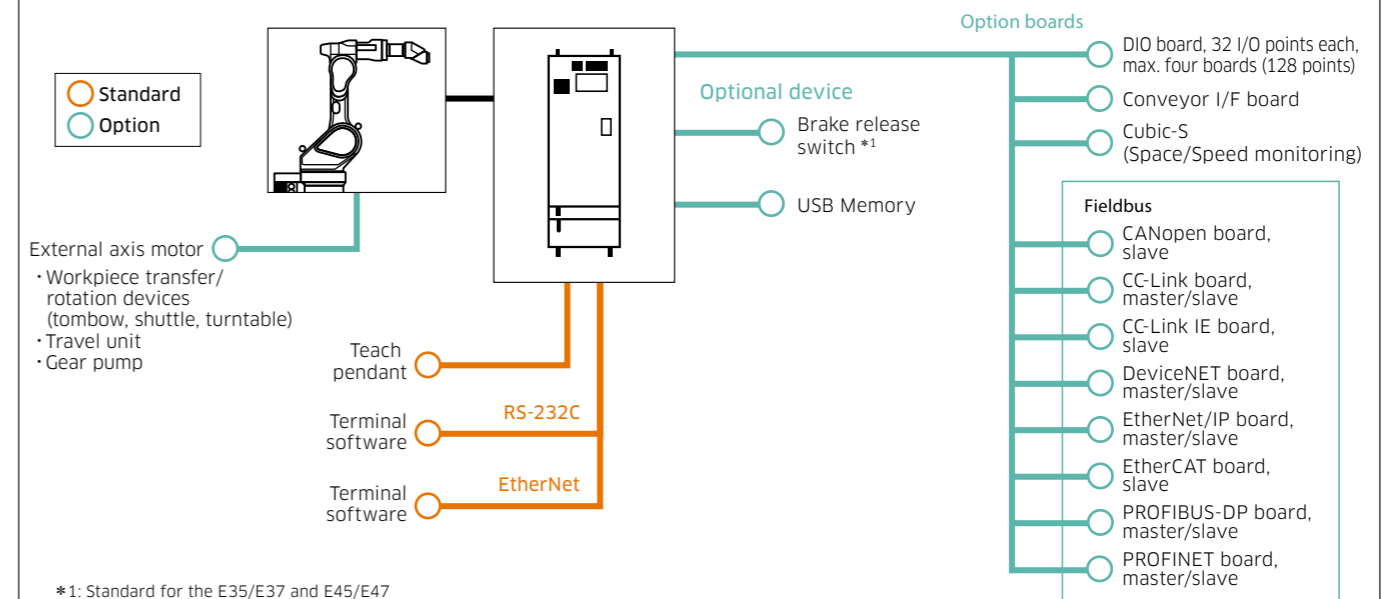

*1: Standard for the E35/E37 and E45/E47

F25, F35, F45

Features

- Compared to the conventional E-series controller, the F Controller is more than 50% smaller in volume and significantly lighter in weight.
- Additionally, the air panel can be mounted directly on top of the controller, allowing for more efficient use of installation space.



Standard Specifications

America & Canada	F35	
Europe	F45	
Japan & Asia	F25	
Dimensions (mm)	W560xD415xH790	
Construction	Enclosed structure Indirect cooling system	
Controlled (axes)	7 (Max. 9)	
Memory capacity (MB)	16	
I/O signals	External operation	Motor power Off, Hold
	Input (Channels)	32
	Output (Channels)	32
Cable length	Robot-controller (m)	3 (Inside the booth, outside the booth)
	Teach pendant (m)	10
Mass (kg)	70(F25), 95(F35), 100(F45)	
Power requirements	F25	AC200V - AC220V ±10%, 50/60Hz, 3 phases
	F35	AC440V - AC480V ±10%, 60Hz, 3 phases
	F45	AC380V - AC415V ±10%, 50/60Hz, 3 phases
Installation environment	Ambient temperature (°C)	0 - 45
	Relative humidity (%)	35 - 85 (non-condensation)
Teach pendant	Color LCD with touch panel Emergency Stop SW, Teach Lock SW and Enable SW	
Operation panel	Emergency Stop SW, Teach/Repeat SW ^{*2}	

*1: Power requirements ensure maximum operation of a robot, not those required for normal operations.
*2: The F45 comes with three switches to change between teach/teach 100%/repeat, as standard equipment.

External view and dimensions

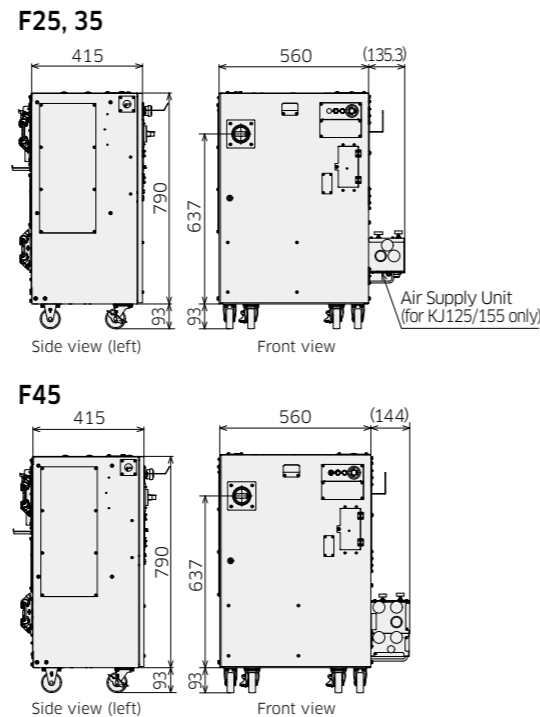

New Lightweight Explosion Proof Teach Pendant

- Reduces weight by more than 30%
- Changing the liquid crystal method to STN
→TFT high-brightness LCD improves brightness and visibility
- Significantly improved viewing angles, reducing the stress of teaching work

Item	Current Explosion-proof Teach Pendant	New Lightweight Explosion-Proof Teach Pendant
Operability	Equivalent (Key Arrangement is the same)	
Size	215(W) x 346(H) x 58(D)	162(W) x 304(H) x 58(D)
Weight	1500g	1000g
Screen Size	7.2inch	5.7inch
LCD	STN Color	TFT Color
Explosion-proof	Structure Intrinsically Safe	

Explosion-proof color LCD with large touch panel enables teaching, editing work, pre-position/I/O signals, and other information in the explosion-proof area monitor and user-customizable interface panel. Also, back it also has a light, so the screen is clear even in low light conditions.



USER FRIENDLY OPERATION

The easy to use intrinsically safe teach pendant now incorporates a low-voltage color LCD touchscreen as well as motor power and cycle start at your fingertips while programming inside the paint booth. Multiple information screens can be displayed simultaneously including spray condition and diagnostics. The intuitive teaching interface is simple to use.



ADVANCED TECHNOLOGIES

The high performance CPU provides extremely accurate trajectory control, high-speed program execution as well as extremely fast loading and saving of files. Two Ethernet ports are available for the user to connect directly to a laptop or to an Ethernet network to remotely save programs or monitor the process.



System configuration

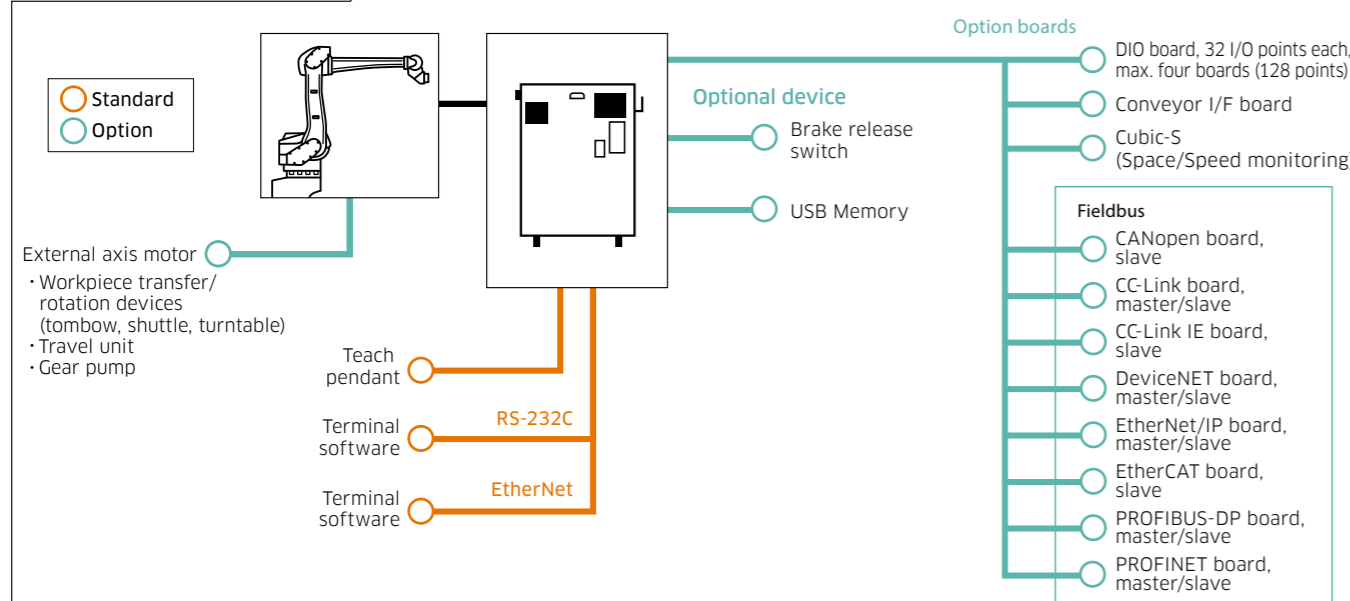

EASY MAINTENANCE

Modular components with limited cables allow for easy diagnostics and maintenance. On board self diagnostics minimizes troubleshooting and reduces MTTR. Remote Diagnostics via the web server option enables service support from anywhere in the world. The E35/37 controller's main circuitry modules, including the I/O boards and MC unit, are interchangeable with non-paint E controllers reducing spare parts inventory and order lead time. All standard circuitry and intrinsically safe components are now mounted inside the main controller enclosure, eliminating the bulky side box.



EXPANDABLE

Three additional axes can be added for control of process equipment and a 7th axis rail. Numerous communication field buses are available for controlling peripheral devices. The controller supports a wide range of fieldbus protocols for peripheral device control. It can implement either the KLogic software sequencer, which allows program editing directly from the teach pendant, or the CODESYS software PLC, which complies with the international IEC 61131-3 standard. These capabilities make it easy to build sophisticated automation systems.



Small sized painting applications Servo Tombow

Space saving and easy-to-install

1. Smooth movement

Servo motion control provides smooth movement to eliminate work slippage.

2. Higher painting quality

For small cubical boxes (electronic appliances such as TV cabinets.), the spray gun can be oriented to each surface at a right angle. The distance between the gun and the surface can also be adjusted simply by entering a value. These features enable easy operation and enhance the painting quality.

3. Synchronous operation with the robot

The Servo Tombow's table rotation is synchronized with the robot movements, assuring a uniform paint finish for cylindrical shaped components such as hot plates, wooden trays and automobile hubs. The Tombow table offers 360 degrees of rotation.

4. Preventing paint mist accumulation

To reduce the problem of paint mist accumulation, workpieces can be positioned above a water tank when spraying.

Standard Specifications

	Standard	Heavy load type
Table load	20 kg x 2 Table	40 kg x 2 Table
No. of control (axes)	Robot 6+Servo tombow 2	
Control method	Servo control	
Teaching playback method	PTP teaching+CP control	
Position detection method	Absolute encoder	
Arm	Diameter (mm)	1,000, 1,200, 1,400, 1,600, 1,800
	Operation angle (°)	180°
	Indexing time (sec)	2.0/180° / 2.4/180°
Table	Operation angle	Infinite revolution
	Indexing angle (°)	90-deg and arbitrary angle
	Indexing time (sec)	0.8/90° / 1.2/90°
	Uninterrupted rotary speed (rpm)	Max. 90 / Max. 45
	Rotary direction	Normal/reverse rotation
Explosion protection	Air pressurized explosion protection and intrinsically safe, Explosion-proof composite type (Expib II BT4 / Exib II BT4)	
Mass (kg)	Approx. 140 - 160	
Color	Munsell 10GY9/1 equivalent	

Note: The standard arm lengths are 1,000 mm, 1,200 mm, 1,400 mm, 1,600 mm and 1,800 mm. The work loading table and loading fixtures to be prepared by the purchaser.

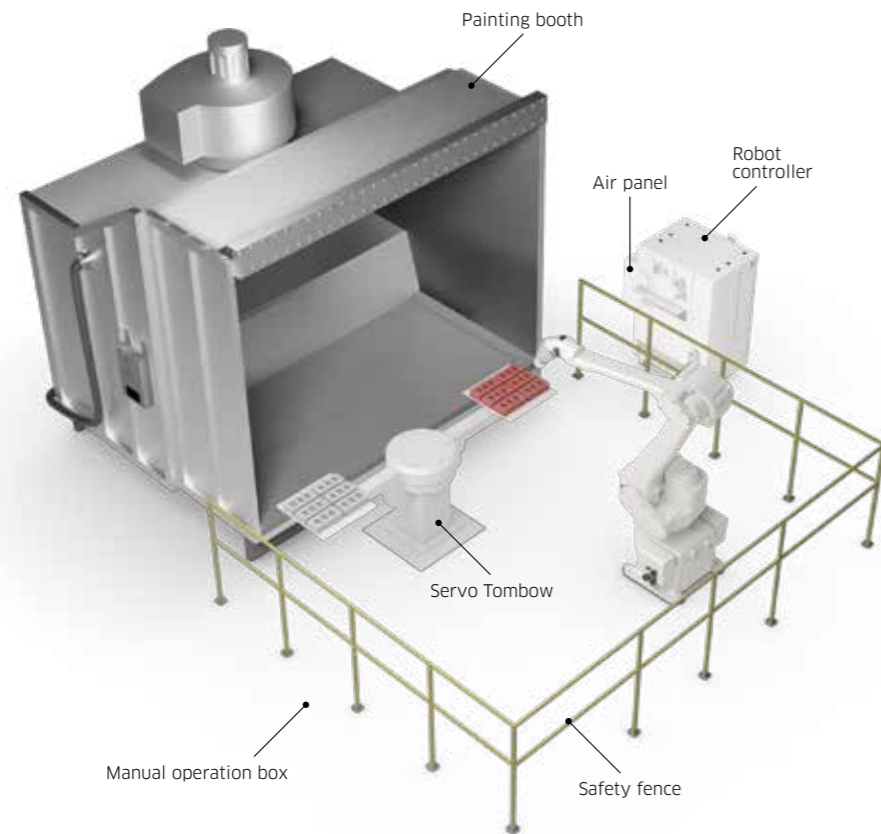

Small sized painting applications Servo Tombow-R

Enhanced space efficiency

1. Space efficient

The paint robot is installed at the center of the Servo Tombow painting system, thereby achieving a greater space efficiency.

2. Adaptability to different painting conditions

The tables and arm can be positioned and speed-controlled with a high level of precision. The tables can also be continuously rotated and fixed at any desired angle, making it possible to select the best painting method for the workpiece.

3. Enhanced paint quality

There are few obstacles surrounding the tables, allowing the paint robot to freely change its posture. The lack of obstacles also means that the airflow inside the booth does not become too turbulent. These advantages lead to an improved level of paint quality.

4. Ideal for automated transportation equipment

This system attaches and removes workpieces behind the paint robot. As a result, this system can be easily combined with automated transportation equipment that uses conveyors or delivery robots.

Standard Specifications

	Standard	Heavy load type
Table load	20 kg x 2 Table	40 kg x 2 Table
No. of control (axes)	Robot 6+Servo tombow-R 2	
Control method	Servo control	
Teaching playback method	PTP teaching+CP control	
Position detection method	Absolute encoder	
Arm	Diameter (mm)	1,800, 2,000, 2,200, 2,400, 2,600
	Operation angle (°)	180
	Indexing time (sec)	4.0/180°
Table	Operation angle	Infinite revolution
	Indexing angle (°)	90-deg and arbitrary angle
	Indexing time (sec)	1.0/90° / 1.7/90°
	Uninterrupted rotary speed (rpm)	Max. 120 / Max. 45
	Rotary direction	Normal/reverse rotation
Explosion protection	Air pressurized explosion protection and intrinsically safe, Explosion-proof composite type (Expib II BT4 / Exib II BT4)	
Mass (kg)	Approx. 550 - 690 (excluding the manipulator base)	
Color	Munsell 10GY9/1 equivalent	

Note: A set of work loading tables and loading fixtures are necessary. Install the Manipulator KF121 onto a tombow-R with an arm length of 1,800 mm or 2,000 mm. Install the Manipulator KF192/193/194 onto a tombow-R with an arm length of 2,200 mm or 2,600 mm.

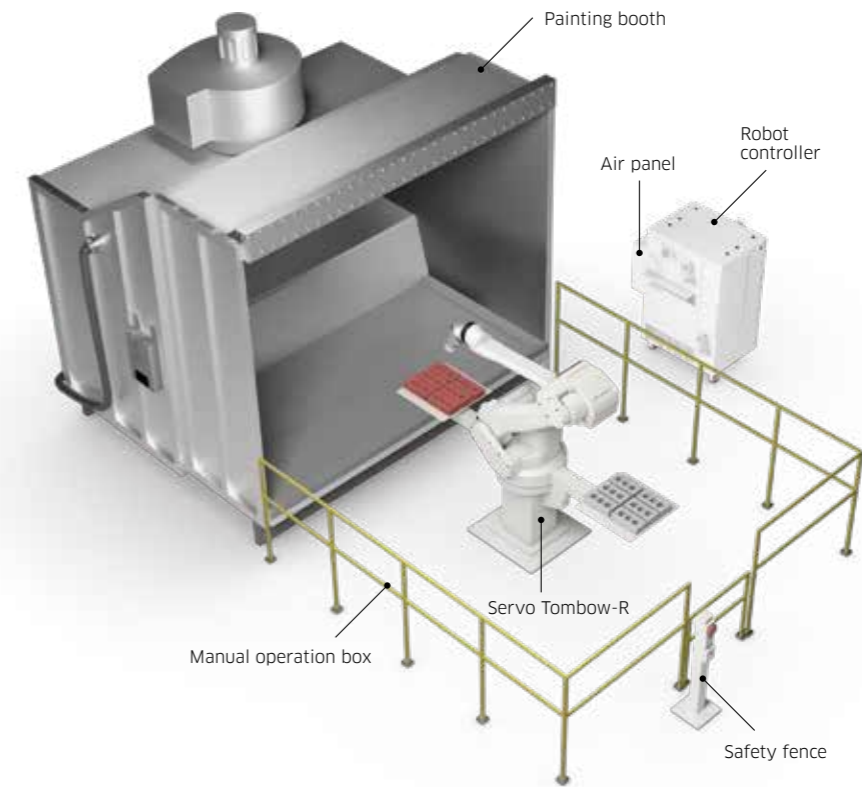

External view and dimensions

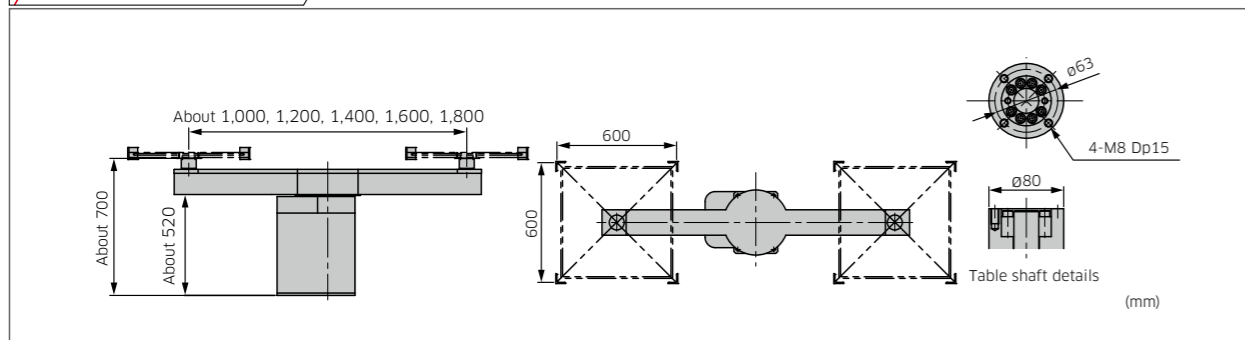

External view and dimensions

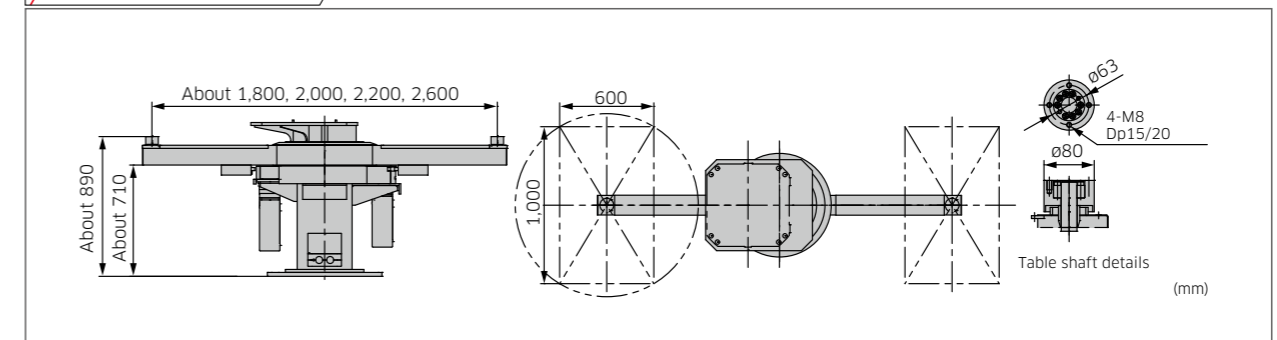

Small sized painting applications Servo Twister

A compact but sophisticated system

1. Small installation space

The minimum installation space required for this system is 2,200 mm wide x 1,966 mm long for a 600 x 600 mm table. Such compactness allows you to install this system in a narrow hand-blowing booth.

2. Rotary table functions

In spite of its small size the Servo Twister provides rotary coating, indexed coating and rotary synchronization functions.

3. 6-axis robots

The Servo Twister installation uses a 6-axis, articulated robot.

4. Shared coating program

The integration of the robot and painting table into one unit allows for programs to be shared by more than one robot.

5. Short installation time

The servo twister cell can be built before delivery, so that the time for installation could be done as quick as one day.

Standard Specifications

		Standard
Table load		20 kg x 2 Table
No. of control (axes)		Robot 6+Servo twister 2
Control method		Servo control
Teaching playback method		PTP teaching+CP control
Position detection method		Absolute encoder
Arm	Diameter (mm)	650, 800
	Operation angle (°)	135
	Indexing time (sec)	1.8/135°
Table	Operation angle	Infinite revolution
	Indexing angle (°)	90-deg and arbitrary angle
	Indexing time (sec)	0.8/90°
	Uninterrupted rotary speed (rpm)	Max. 90
	Rotary direction	Normal/reverse rotation
Explosion protection		Air pressurized explosion protection and intrinsically safe. Explosion-proof composite type (Expib II BT4 / Exib II BT4)
Mass (kg)		120
Color		Munsell 10GY9/1 equivalent

Note : The work loading table and loading fixtures to be prepared by the purchaser.

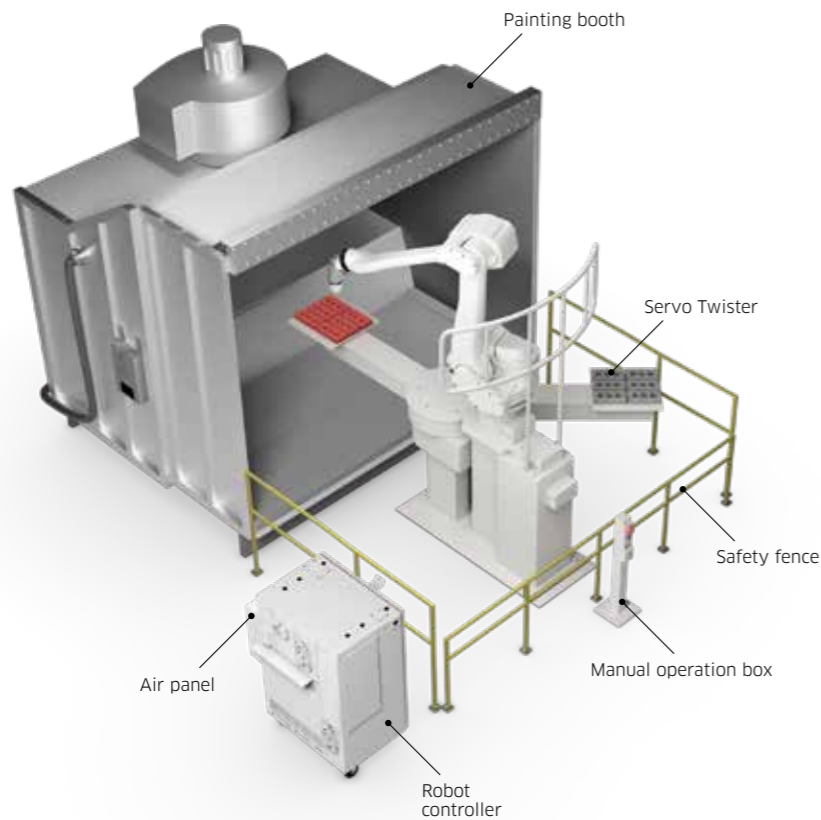

Medium sized work-piece painting cell Servo Shuttle

Ultimate "table painting" type

1. Improvement in productivity

Servo motion provides high speed work transfer and table rotation with shock-less smooth start and stop motion, and also enables continuous rotation tracking with robot and any stand-by position of feeder.

2. Higher coating quality

Controlling the position of the table provides the optimum painting position. This combined with the high-speed, high-precision robot with the servo shuttle enables high-quality painting.

3. Simple teaching

The simple teaching function provided by the KF series painting robot eliminates time-consuming program teaching.

4. Increased table load

The system can be used for painting large TV cabinets, sanitary ware, automobile instrument panels etc.

5. Simple installation

This complete package is simple to install, but will provide for the painting of the most complex of components. installation could be done as quick as one day.

Standard Specifications

		Standard	Heavy load type
Table load		20 kg x 2 Table	60 kg x 2 Table
No. of control (axes)		Robot 6+Servo shuttle 2	
Control method		Servo control	
Teaching playback method		PTP teaching+CP control	
Position detection method		Absolute encoder	
Shuttle	Stroke (mm)	2,000, 2,700, 3,200, 4,000	
	Max. speed (mm/秒)	1,000	
Table	Operation angle	Infinite revolution	
	Indexing angle (°)	90-deg and arbitrary angle	
	Indexing time (sec)	0.8/90°	1.2/90°
	Uninterrupted rotary speed (rpm)	Max. 90	Max. 45
Rotary direction		Normal/reverse rotation	
Intermediate stop function		The intermediate stop function and multiple coating control function are available.	
Explosion protection		Air pressurized explosion protection and intrinsically safe. Explosion-proof composite type (Expib II BT4 / Exib II BT4)	
Mass (kg)		One side: 300 to 500	
Color		Munsell 10GY9/1 equivalent	

Note : The work loading table and loading fixtures to be prepared by the purchaser.

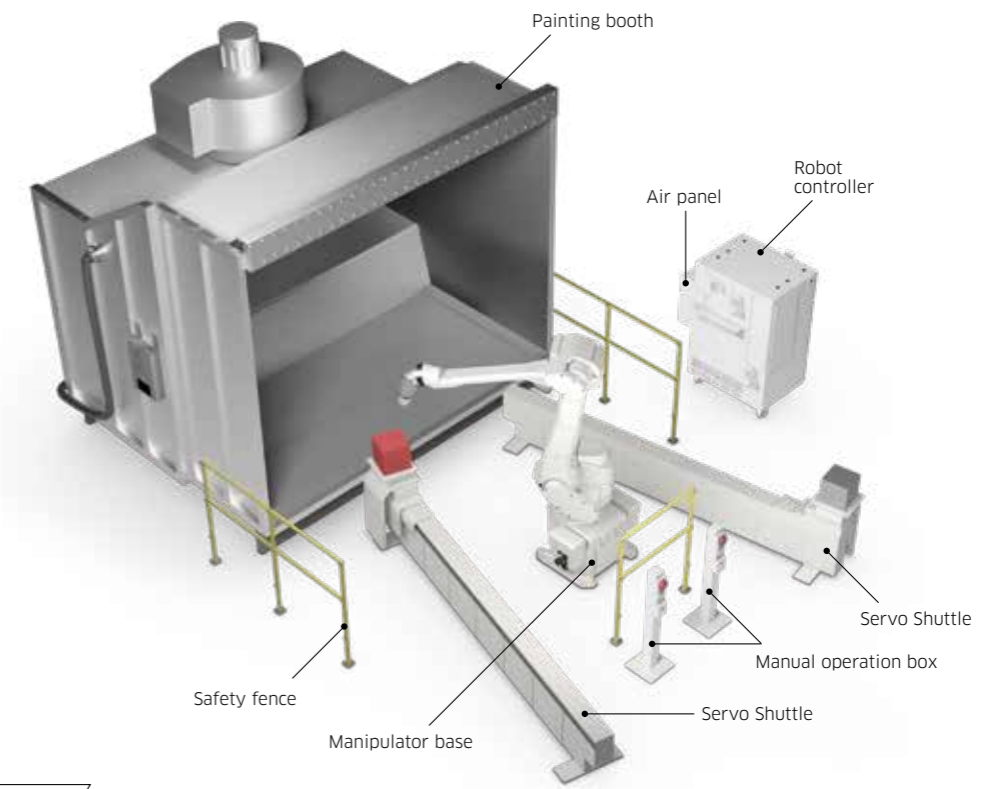

External view and dimensions

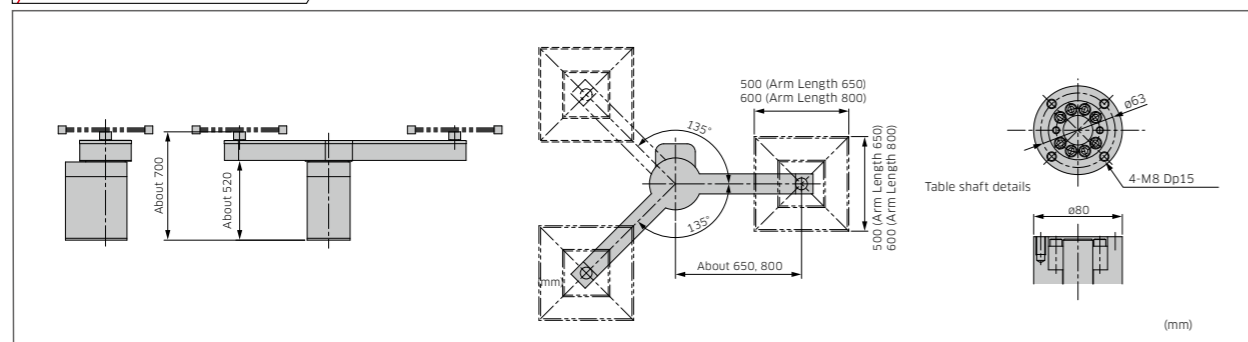

External view and dimensions

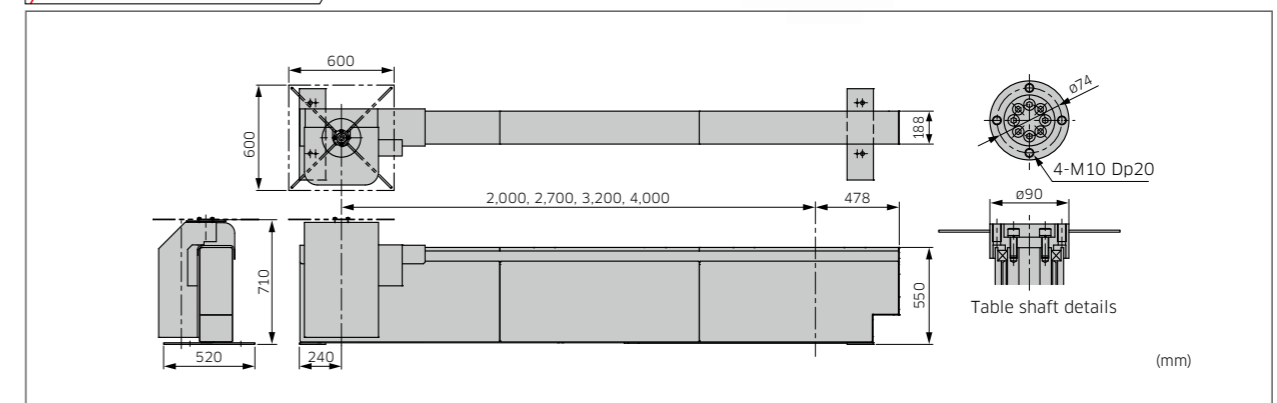

Medium sized work-piece painting cell Servo Wing

The installation space for "Table Painting" was made even smaller.

1. Space saving

While suitable for workpieces of a larger size than in the Servo Shuttle, the installation space is made smaller. Because the left and right workpieces are closer together, loading and unloading work is reduced.

2. Even small-sized robots can handle large workpieces

Because there is one painting position, the distance between the workpiece and the robot becomes closer, making the robot possibly smaller than that in the Servo Shuttle.

3. Less teaching work

Because the left and right arms can be set for the same painting positions (one position), a single program can be used, thus making the teaching time shorter.

4. Preventing paint mist accumulation

Because the arms are slim with no fixed rails, painting can be conducted above the water, reducing soiling of the booth. In addition, the airflow turbulence inside the paint booth can be minimized.

5. Short Construction Period

This device is delivered pre-assembled. So, it can be installed in as short as one day and you can start production immediately.

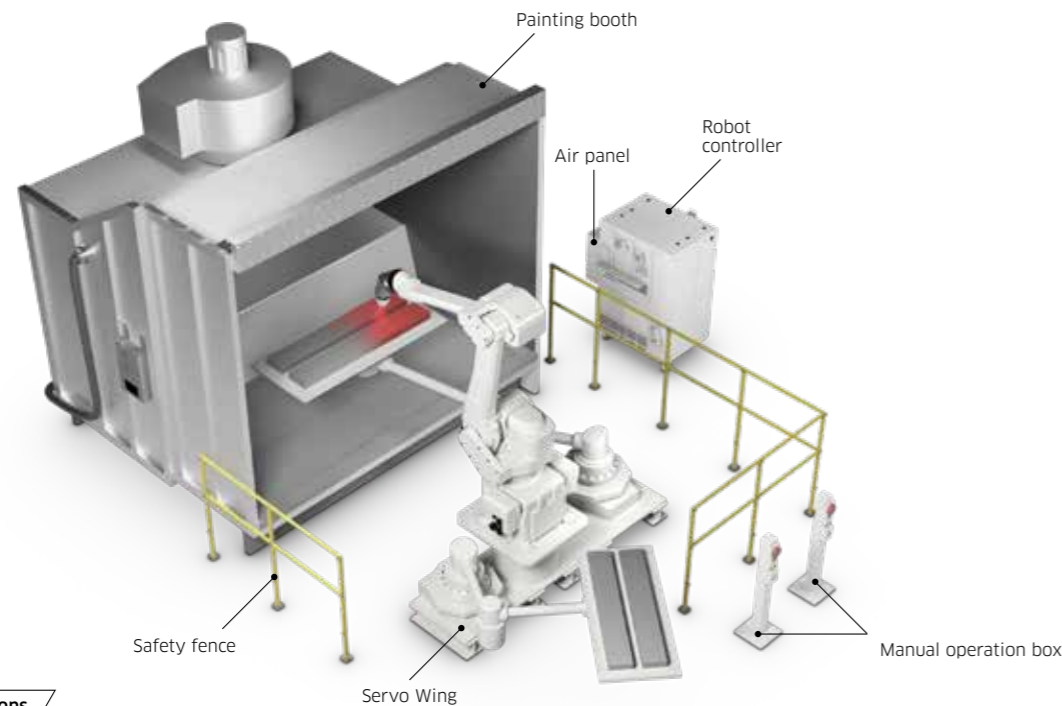

Standard Specifications

Table load	30 kg x 2 Table	
No. of control (axes)	Robot 6+Servo wing 2	
Control method	Servo control	
Teaching playback method	PTP teaching+CP control	
Position detection method	Absolute encoder	
Arm	Diameter (mm)	2,670
	Operation angle (°)	3.2
Table	Operation angle	Infinite revolution
	Indexing angle (°)	90-deg and arbitrary angle
	Indexing time (sec)	1.2/90°
	Uninterrupted rotary speed (rpm)	Max. 90
Rotary direction	Normal/reverse rotation	
Intermediate stop function	The intermediate stop function and multiple coating control function are available.	
Explosion protection	Air pressurized explosion protection and intrinsically safe. Explosion-proof composite type (Expib II BT4 / Exib II BT4)	
Mass (kg)	970	
Color	Munsell 10GY9/1 equivalent	

Note: The arm index time indicates the time of arm movement from the intermediate stop position to the painting position.
The arm index time varies depending on the intermediate stop position.

External view and dimensions

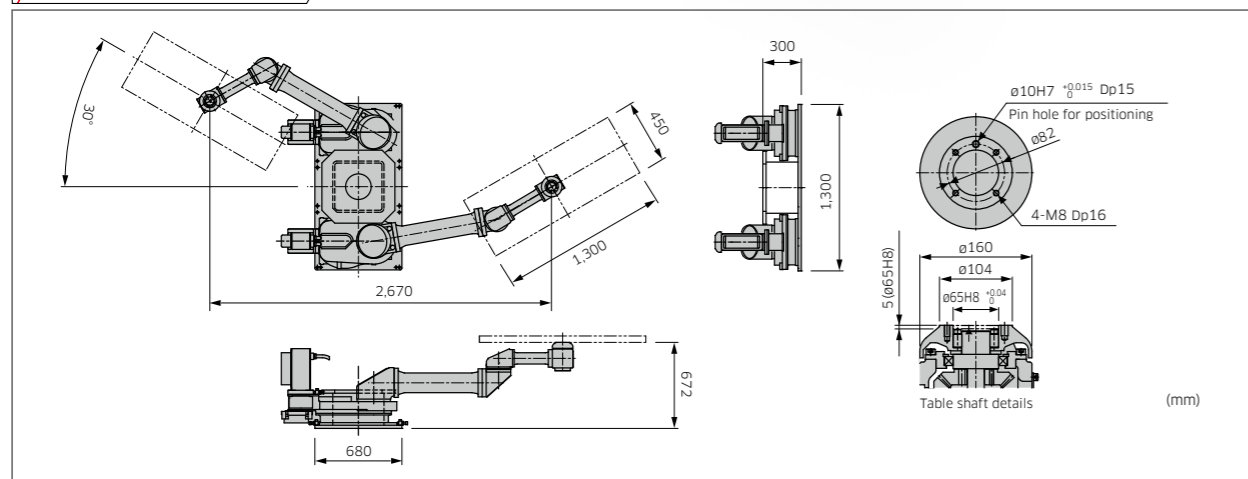

Medium sized work-piece painting cell Servo Spinner

A new dimension in "line coating"

1. Flexible component placement

Choose the optimum painting posture for the workpiece, and reduce contamination of the paint booth.

2. Uninterrupted painting

Painting can be performed with the table rotating, thus minimizing the robot's wait time.

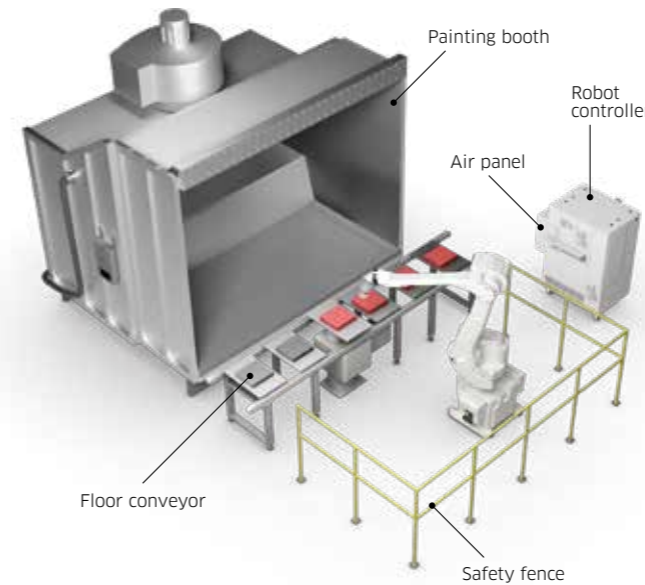

Standard Specifications

	Standard	Heavy load type	
Table load	20	60	
No. of control (axes)	Robot 6+Servo Spinner 1		
Control method	Servo control		
Teaching playback method	PTP teaching+CP control		
Position detection method	Absolute encoder		
Table	Operation angle	Infinite revolution	
	Indexing angle (°)	90-deg and arbitrary angle	
	Indexing time (sec)	0.8/90°	1.1/90°
	Uninterrupted rotary speed (rpm)	Max. 90	Max. 45
	Rotary direction	Normal/reverse rotation	
Explosion protection	Air pressurized explosion protection and intrinsically safe. Explosion-proof composite type (Expib II BT4 / Exib II BT4)		
Mass (kg)	60		
Color	Munsell 10GY9/1 equivalent		

External view and dimensions

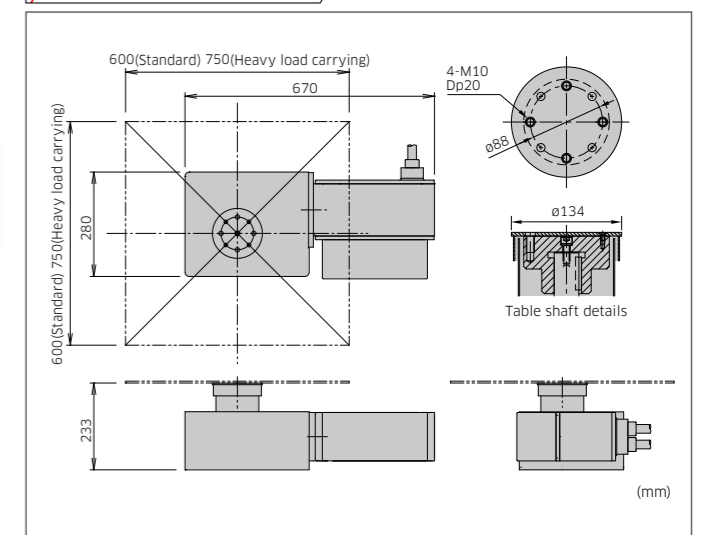

Large sized work-piece painting cell Servo Turntable

Complete surface painting is possible with uninterrupted turntable rotation

1. The integrated control of the robot and table allows any painting position to be achieved according to the work shape.

2. The system can be applied to various types of painting such as synchronous control, arbitrary-angle indexing and paint spraying with continuous rotation of the table.

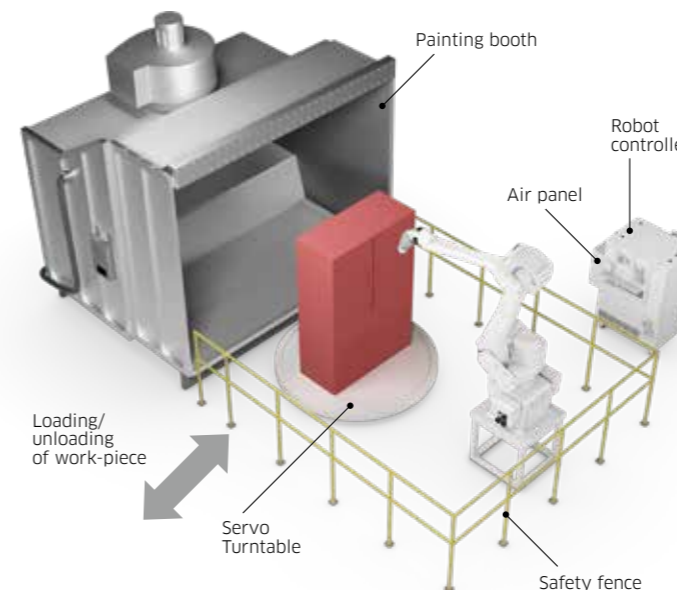

Standard Specifications

	Standard	Heavy load type	
Table load (kg)	Max. 500	Max. 1,000	
No. of control (axes)	Robot 6+Servo Turntable 1		
Control method	Servo control		
Teaching playback method	PTP teaching+CP control		
Position detection method	Absolute encoder		
Table	Operation angle	Infinite revolution	
	Indexing angle (°)	90-deg and arbitrary angle	
	Indexing time (sec)	2.5/90°	5/90°
	Uninterrupted rotary speed (rpm)	Max. 10	Max. 5
	Rotary direction	Normal/reverse rotation	
Explosion protection	Air pressurized explosion protection and intrinsically safe. Explosion-proof composite type (Expib II BT4 / Exib II BT4)		
Mass (kg)	180 (without table jig)		
Table diameter (mm)	up to ø2,000		
Color	Munsell 10GY9/1 equivalent		
Foot switch function (Option)	Uninterrupted normal rotation, rotation stop	Uninterrupted rotation, 45-deg, 90-deg, 180-deg, indexing (changeable indexing angle), rotation stop	

External view and dimensions

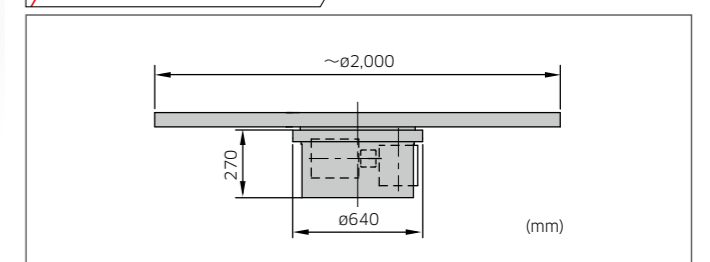

Medium sized work-piece painting cell Tilt Spinner

It is a new style of "line painting".

- 1. Arbitrary positioning of the workpiece on the line**
The robot can adopt a painting posture that matches the shape of the workpiece, allowing for a comfortable setup that reduces booth contamination.
- 2. Continuous rotation painting is possible**
Continuous rotation of the table enables painting during movement, minimizing robot idle time.

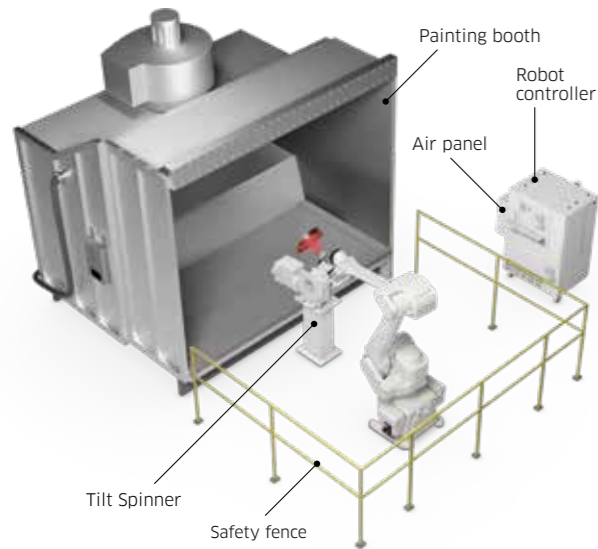

Standard Specifications		
No. of control (axes)	Robot 6+Servo tomow-R 2	
Control method	Servo control	
Teaching playback method	PTP teaching+CP control	
Position detection method	Absolute encoder	
Inclined axis	Operation angle (°)	±45°
	Indexing time* (sec)	1.0/45°
Operation angle	Operation angle (°)	Infinite revolution
	Indexing angle (°)	90-deg and arbitrary angle
	Indexing time* (sec)	0.9/90°
	Uninterrupted rotary speed (rpm)	Max. 60
	Time to Reach Maximum Table Speed	0.4 sec
	Rotation Direction	Forward/Reverse Rotation
Payload	40kg	
Allowable Inertia Moment	Maximum 4.2 kg·m ²	
Workpiece Size	700mm x 700mm	
Explosion-proof composite type	Air pressurized explosion protection and intrinsically safe. (Expib II BT4 / Exib II BT4)	
Mass (kg)	270kg	
Color	Munsell 10GY9/1 equivalent	
Motion range (°)	-	
Mounting	Floor	
Installation environment	Ambient temperature (°C) 0 - 40 Relative humidity (%) 35 - 85 (No dew, nor frost allowed)	
Air Supply	Clean, dry air : 0.08Nm ³ /min, 0.4~0.7MPa Atmospheric dew point : -17°C or lower Solid particles : 0.01µm or smaller Oil content : Mist removal efficiency 99.999% or higher	
Options	None	

*Arm indexing time refers to the time from the intermediate stop position to the painting position. Arm indexing time varies depending on the intermediate stop position.

Kawasaki's cooperative coating technology

Next-generation coating solutions that deliver high quality, energy efficiency, and operational effectiveness.

Technical Overview

Cooperative painting is a control technology that synchronizes the movements of the painting and transport robots, optimizing the relative motion and spray angle of the paint gun. This enhances production efficiency while maintaining high paint quality.



The coating process is one of the most demanding energy consumption at manufacturing sites, and it is necessary to improve it to achieve carbon neutrality. Kawasaki proposes a new collaborative coating solution that enhances quality while reducing energy consumption and costs—achieved through synchronized operation of multiple robots.

Main Advantages

Stabilization of paint quality

Optimizing the workpiece orientation relative to the spray surface improves film thickness uniformity and color tone stability. It also supports electrostatic coating for a refined, high-quality finish.

Reduced paint usage

Enhanced application efficiency minimizes overspray, reducing paint consumption and lowering operational costs.

Reduced takt time

Coordinated movement with the transport robot maintains application speed while minimizing acceleration and deceleration of the paint gun, boosting overall productivity.

Efficiency of equipment start-up

Shared coordinate systems between robots reduce setup errors and simplify teaching and adjustments, shortening start-up time.

Reduced maintenance load

Optimizing the spray direction reduces paint scattering, resulting in less booth contamination and lower cleaning and maintenance workload.

neoROSET is a programming tool that enables robot programming and accurate simulation on a PC. By performing offline verification in advance, risks that may be concerned about introducing a robot system can be reduced.



Flow of using the system

neoROSET provides maximum effectiveness with simple operation.

Placement considerations

Interactive operation makes it easy to add robots and workpieces and modify their placement. Even those who are unfamiliar with design work can confidently check whether a robot can reach a workpiece.

Teaching and programming

You can easily create machining operations by snapping to vertices and edges of CAD data and adding teaching points directly to the workpiece. You can also easily program by adding items that display explanations of commands.

Simulation

The movement of robots and peripheral devices, as well as interference conditions when models come into contact, can be displayed, allowing you to prevent system problems before they occur. You can also check the status of currently executing program steps and signals, shortening the time it takes to find problems.

Application to actual equipment

Programs created with neoROSET can be loaded to the actual machine, or saved to neoROSET. You can also monitor the robot's posture and signal status, reducing on-site adjustment time.

Dramatically reduces teaching time

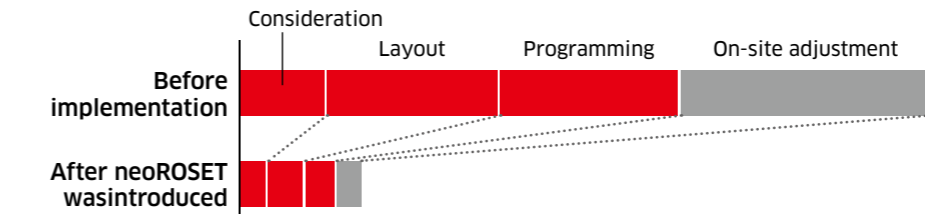

By using neoROSET, the time required for conventional offline teaching and adjustment can be reduced to a fraction or even up to one-tenth.

CAD formats are supported as standard!

neoROSET can import data from many commonly used 3D CAD programs and use it to create programs. This allows you to build an environment where CAD data and robots can be used, seamlessly connecting the design department and the manufacturing site. In addition, it is backward compatible with the conventional software K-ROSET, and can load K-ROSET projects.

*Supported CAD formats are updated from time to time.

Simple and intuitive operation



Its intuitive graphical user interface allows users to visually create robot programs, even without specialized programming knowledge.

Display of processing results

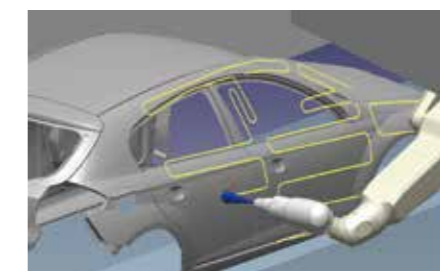

The trajectory of the machining results when welding or painting commands are executed can be displayed separately from the air cutting operation.

Operating environment

Item	Contents
Operating System (OS)	Windows(R) 10 Pro x64/Windows(R) 10 Enterprise x64 Windows(R) 11 Pro x64/Windows(R) 11 Enterprise x64 Japanese version / English version / Chinese version / German version
CPU	Intel Core i5 or higher recommended
Memory	Minimum 8GB RAM, 16GB or more recommended
Free space	30GB or more, Solid State Drive (SSD) recommended
Resolution	1920 x 1080 or higher recommended
Video card	Intel UHD Graphics or higher / NVIDIA Quadro series recommended
Other requirements	Mouse (with wheel recommended) or equivalent pointing device PDF Reader such as Adobe® Acrobat® Reader

Standard Format

Format	Extension
ACIS	sat
	sab
IGES	iges/igs
STEP	step/stp
DXF	dxg
DWG	dwg
JT	jt
Parasolid	x_t
	x_b
STL	stl

Robot Motion Monitoring Safety Unit

CoreCubic-S is a safety feature that monitors robot behavior with software. Monitor the operation to safely stop the robot or system.



Both the main CPU board and servo board software monitor the robot status. Mutual diagnostics between the two CPUs ensure safety.

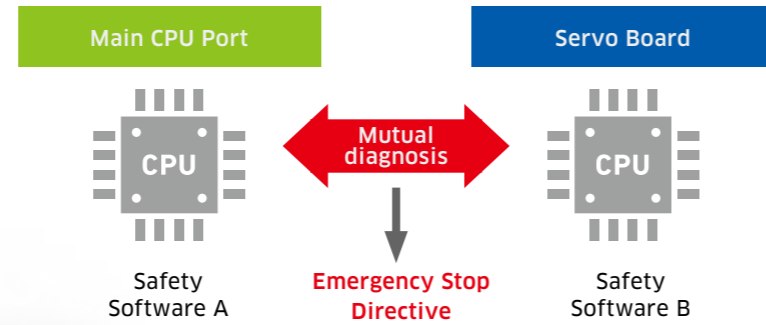

Item	CoreCubs-S
Safety Performance	Protective Stop Function, Emergency Stop Function: PL e (Category 4), SIL3 Other Safety Functions: PL d (Category 3), SIL2
Number of Monitoring Axes	Up to 17 Axes
User Input/Output	DJ Board (Optional) Additional (*2 Points per DJ Board: 8/8 Points) Safety Duplexing Input: 16 points (Max) Safety Duplex Output: 16 points (Max) Tool ID Input: 5 points
Safety Features	Safety Features Operating space monitoring, axis monitoring, speed monitoring, stop monitoring, tool direction monitoring, protective stop, emergency stop, safety state output, EtherNet/IP safety, logic arithmetic



Built-in explosion-proof F-controller

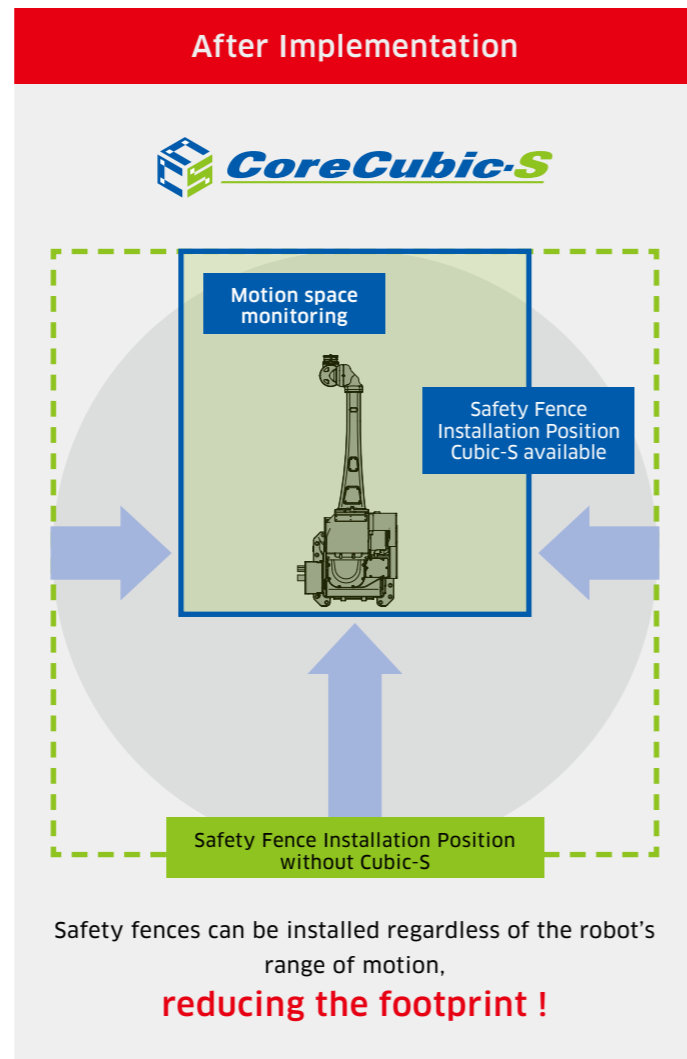
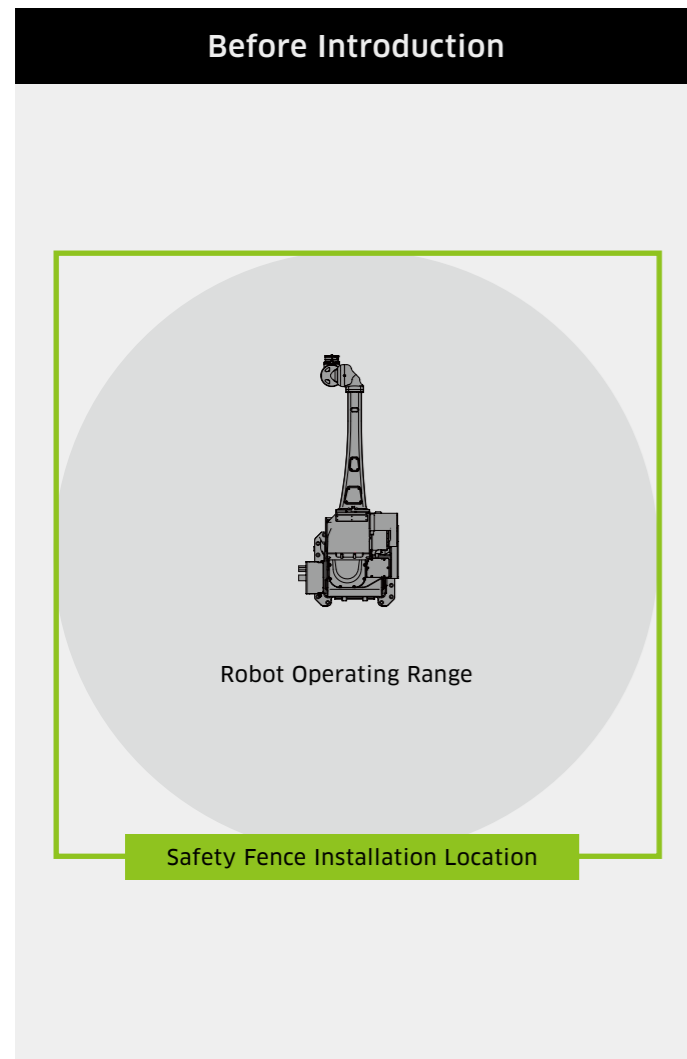

Safety fences can be installed regardless of the robot's range of motion, **reducing the footprint !**

Coating Robot Control System

KOSMOS is a software that sets and displays the painting data associated with each robot.

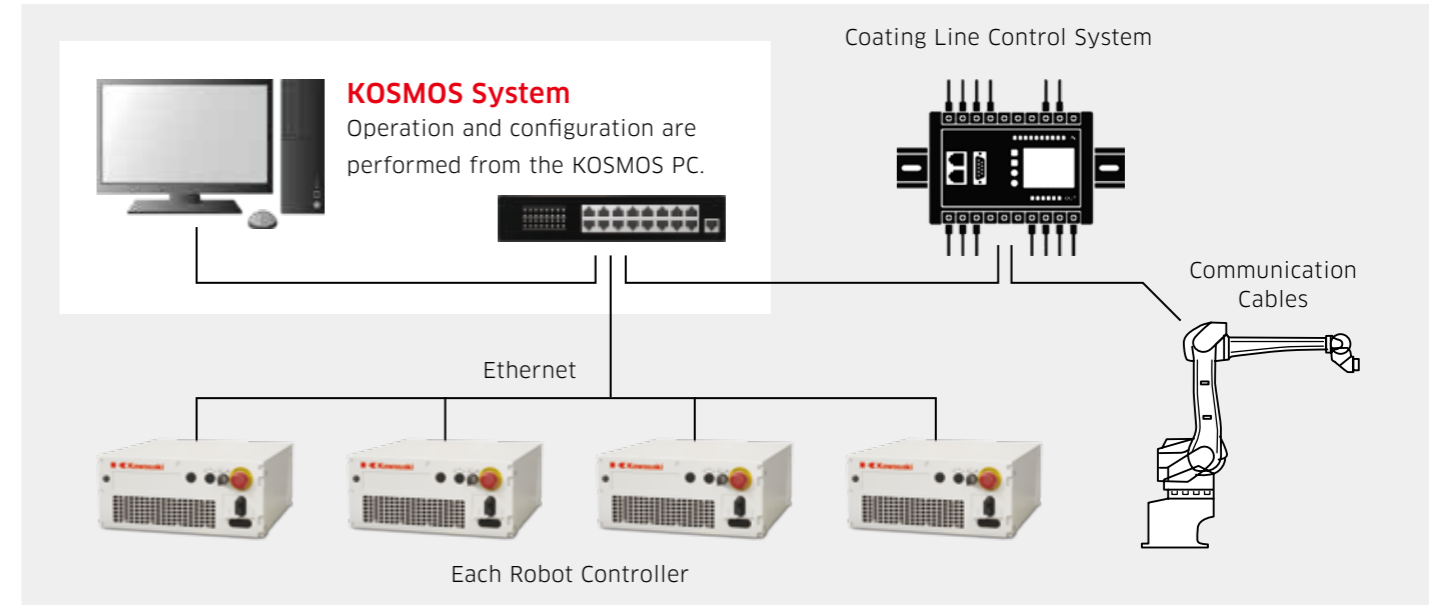

Centralized management of all data

Each axis's software limit and home position settings can be managed directly through the robot program—without the need for a teaching pendant.

What does KOSMOS deal with?

- **Paint condition**
Spraying air/pattern air/spraying volume, high voltage level, etc.
- **Calibration**
- **Statistics, each history check**
Abnormal statistics, data change history, robot utilization rate, paint usage, abnormal history, data change history, etc.
- **Data Save, Data Load**
Teaching Program, System Parameters, Paint Data, Data Backup

Statistics, each history check

The system allows verification of when and by whom data was modified, as well as the specific details of each change.



Paint Data : Paint Equipment Time Chart

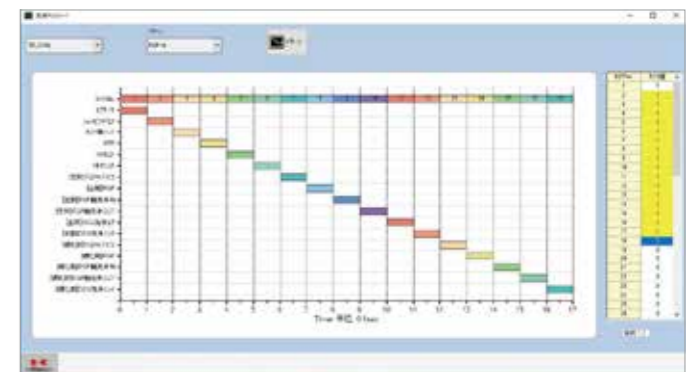

ON/OFF pattern and time to be turned on

Robot Data : Saving and Loading



The program can select individual robots or all robots to be saved and loaded.

