

Kawasaki Heavy Industries, Ltd

Robot Business Division

Tokyo Head Office/Robot Division

1-14-5, Kaigan, Minato-ku, Tokyo 105-8315, Japan
Phone: +81-3-3435-2501 Fax: +81-3-3437-9880

Akashi Works/Robot Division

1-1, Kawasaki-cho, Akashi, Hyogo 673-8666, Japan
Phone: +81-78-921-2946 Fax: +81-78-923-6548

Nishi-Kobe Works/Robot Division

234, Matsumoto, Hasetani-cho, Nishi-ku, Kobe, Hyogo 651-2239, Japan
Phone: +81-78-915-8136 Fax: +81-78-915-8274

Global Network

Kawasaki Robotics (USA), Inc.

28140 Lakeview Drive, Wixom, MI 48393, U.S.A.
Phone: +1-248-446-4100 Fax: +1-248-446-4200

Kawasaki Robotics (UK) Ltd.

Unit 4 Easter Court, Europa Boulevard, Westbrook
Warrington Cheshire, WA5 7ZB, United Kingdom
Phone: +44-1925-71-3000 Fax: +44-1925-71-3001

Kawasaki Robotics GmbH

Im Taubental 32, 41468 Neuss, Germany
Phone: +49-2131-34260 Fax: +49-2131-3426-22

Kawasaki Robotics Korea, Ltd.

43, Namdong-daero 215beon-gil, Namdong-gu, Incheon,
21633, Korea
Phone: +82-32-821-6941 Fax: +82-32-821-6947

Kawasaki Robotics (Tianjin) Co., Ltd.

1-2/F, Building 6, No.19 Xinhuan Road, TEDA, China
Phone: +86-22-5983-1888 Fax: +86-22-5983-1889

Taiwan Kawasaki Robot Center

3F, No.31, Ln.216, Gongyuan Rd., Hsinchu City
30069, Taiwan(R.O.C)
Phone: +886-3-562-0518

Kawasaki Motors Enterprise (Thailand) Co., Ltd.

(Rayong Robot Center)
119/10 Moo 4 T.Pluaek Daeng, A.Pluaek Daeng, Rayong 21140
Thailand
Phone: +66-38-955-040-58 Fax: +66-38-955-145

Singapore Kawasaki Robot Center

100G Pasir Panjang Road #06-10
Singapore 118523
Phone: +65-6513-3145

Kawasaki Robotics India Pvt. Ltd.

Plot No. 136, Sector-37, Pace City 1,
Gurgaon, 122101 Haryana, India
Phone: +91-124-437-1845

Kawasaki Robotics website

<https://kawasakirobotics.com/>



Kawasaki Robostage (showroom)

<https://kawasakirobotics.com/jp-sp/robostage/en/>



Kawasaki Robot

Medical & Pharmaceutical Robots

Small-to-medium robots
up to 80kg payload

Large robots
up to 300kg payload

Extra large robots
up to 1,500kg payload

Dual-arm Collaborative robots

Explosion-proof painting robots

Sealing robots

Arc welding robots

Palletizing robots

Medical & pharmaceutical robots

Picking robots

Wafer transfer robots



CAUTIONS TO BE TAKEN TO ENSURE SAFETY

- For those persons involved with the operation / service of your system, including Kawasaki Robot, they must strictly observe all safety regulations at all times. They should carefully read the Manuals and other related safety documents.
- Products described in this catalogue are general industrial robots. Therefore, if a customer wishes to use the Robot for special purposes, which might endanger operators or if the Robot has any problems, please contact us. We will be pleased to help you.
- Be careful as Photographs illustrated in this catalogue are frequently taken after removing safety fences and other safety devices stipulated in the safety regulations from the Robot operation system.



Medical and Pharmaceutical Robots

Robotics automation is required in the medical and pharmaceutical industries to avoid human errors, contamination and exposure risks to high potency active pharmaceutical ingredients such as anticancer drugs.

MC series

The streamlined arm with a special surface treatment is chemical-resistant, allowing for sterilization by VHP.

[Applications]



Pharmaceutical

Features

- Hollow wrist for built-in cables and hoses.
- Compatible with ISO Class 5 (Fed-class 100) without vacuum piping.
- (MC004V) Special sealing material that enables sterilization by VHP.



MC004V

MC004N

F60

Features

- Universal controller has common specifications to be used worldwide.
- Drastic downsizing has achieved very compact dimensions and light weight (8.3kg). It is easy for a person to carry the controller.

Standard Specifications

Dimensions (mm)	W300×D320×H130	
Type	Open type indirect cooling system (IP20 or equivalent)	
Controlled (axes)	6	
Memory capacity (MB)	16	
I/O signals	External operation	Motor power off, Hold
	Input (Channels)	16
Cable length	Teach pendant (m)	5
	Robot-controller (m)	5
Mass (kg)	8.3	
Power requirements	AC200 - AC230V ±10%, 50/60Hz, 1Φ	
	Max. 2.0kVA	
Installation environment	Ambient temperature (°C)	0 - 45
	Relative humidity (%)	35 - 85 (No dew, nor frost allowed)
Teach pendant	TFT color LCD display with touch-panel, E-Stop switch, Teach lock switch, Enable switch	
Operation panel	E-stop switch, teach/repeat switch	



External view and dimensions

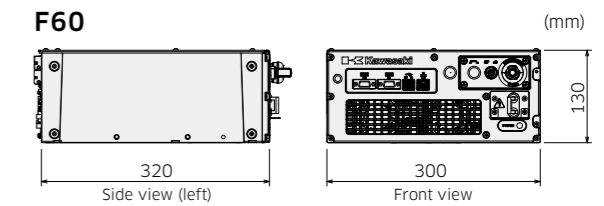

MC004N

Standard Specifications

Type	Articulated robot	
Degree of freedom (axes)	6	
Payload (kg)	4	
Max. reach (mm)	505.8	
Position repeatability*1 (mm)	±0.028	
Motion range (°)	Arm rotation (JT1)	±180
	Arm out-in (JT2)	+135 - -95
	Arm up-down (JT3)	+60 - -155
	Wrist swivel (JT4)	±270
	Wrist bend (JT5)	±120
	Wrist twist (JT6)	±270
Max. speed (°/s)	Arm rotation (JT1)	200
	Arm out-in (JT2)	180
	Arm up-down (JT3)	225
	Wrist swivel (JT4)	700
	Wrist bend (JT5)	500
	Wrist twist (JT6)	350
Allowable moment (N·m)	Wrist swivel (JT4)	8.5
	Wrist bend (JT5)	8.5
	Wrist twist (JT6)	4.0
Allowable moment of inertia (kg·m²)	Wrist swivel (JT4)	0.2
	Wrist bend (JT5)	0.2
	Wrist twist (JT6)	0.1
Mass (kg)	25	
Mounting	Floor, Ceiling	
Installation environment	Ambient temperature (°C)	10 - 35
	Relative humidity (%)	35 - 85 (No dew, nor frost allowed)
Degree of protection*2	Wrist : IP67 or equivalent Base axes : IP65 or equivalent	
Controller/Power requirements	F60/2.0kVA	

*1: Conforms to ISO9283
*2: The flange must be closed in case of using the built-in piping.

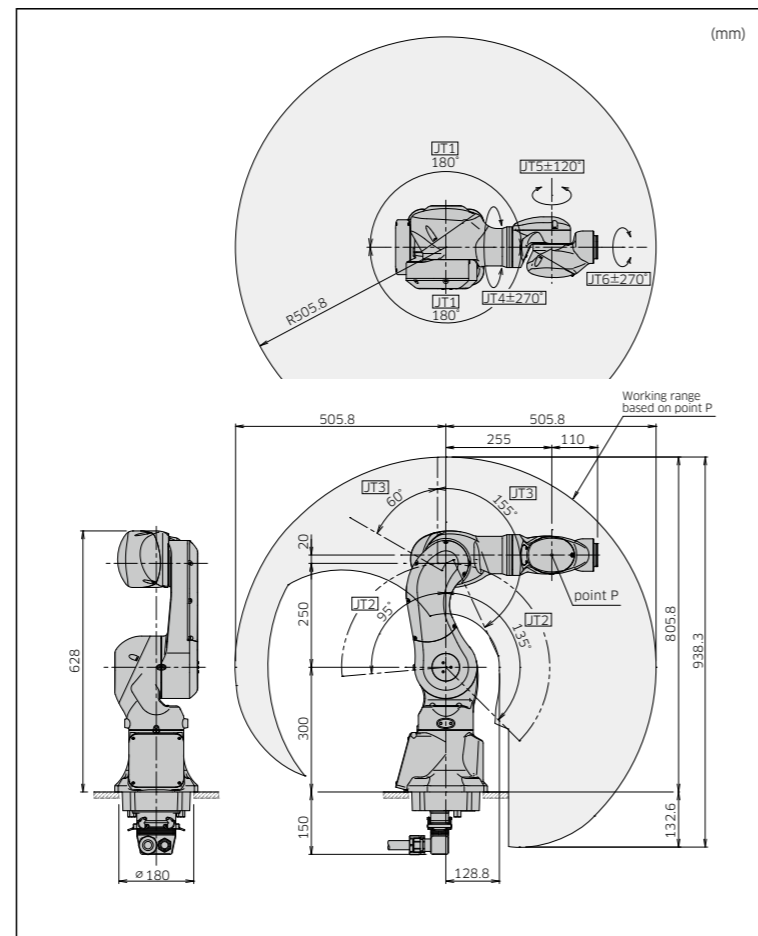

MC004V

Standard Specifications

Type	Articulated robot	
Degree of freedom (axes)	6	
Payload (kg)	4	
Max. reach (mm)	505.8	
Position repeatability*1 (mm)	±0.028	
Motion range (°)	Arm rotation (JT1)	±180
	Arm out-in (JT2)	+135 - -95
	Arm up-down (JT3)	+60 - -155
	Wrist swivel (JT4)	±270
	Wrist bend (JT5)	±120
	Wrist twist (JT6)	±270
Max. speed (°/s)	Arm rotation (JT1)	200
	Arm out-in (JT2)	180
	Arm up-down (JT3)	225
	Wrist swivel (JT4)	700
	Wrist bend (JT5)	500
	Wrist twist (JT6)	350
Allowable moment (N·m)	Wrist swivel (JT4)	8.5
	Wrist bend (JT5)	8.5
	Wrist twist (JT6)	4.0
Allowable moment of inertia (kg·m²)	Wrist swivel (JT4)	0.2
	Wrist bend (JT5)	0.2
	Wrist twist (JT6)	0.1
Mass (kg)	25	
Mounting	Floor, Ceiling	
Installation environment	Ambient temperature (°C)	10 - 35
	Relative humidity (%)	35 - 85 (No dew, nor frost allowed)
Degree of protection*2	Wrist : IP67 or equivalent Base axes : IP65 or equivalent	
Controller/Power requirements	F60/2.0kVA	

*1: Conforms to ISO9283
*2: The flange must be closed in case of using the built-in piping.
*3: Special sealing material that enables sterilization by VHP.

