

**Kawasaki Robot
MG Series (Ver. B)**

**Installation and
Connection Manual**

Robot

Kawasaki Heavy Industries, Ltd.

Preface

This manual describes installation and connection procedures for Kawasaki Robot MG Series (Ver. B).

Read and understand the contents of this and “Safety Manual” thoroughly and strictly observe all rules for safety before proceeding with any operation. This manual describes only the installation and connection of the robot arm. Please refer to the following manuals for installation and connection of controller and for operation of the robot.

“Installation and Connection Manual” for controller

“Operation Manual” for controller

Never proceed with any operation until you understand the contents of this manual completely. Kawasaki cannot take any responsibility for any accidents and/or damages caused by operations that are based on only the limited part of this manual.

This manual is applicable to the following robot arms.

MG10HL, MG15HL

-
1. This manual does not constitute a guarantee of the systems in which the robot is utilized. Accordingly, Kawasaki is not responsible for any accidents, damages, and/or problems relating to industrial property rights as a result of using the system.
 2. It is recommended that all personnel assigned for activation of operation, teaching, maintenance or inspection of the robot attend the necessary education/training course(s) prepared by Kawasaki, before assuming their responsibilities.
 3. Kawasaki reserves the right to change, revise, or update this manual without prior notice.
 4. This manual may not, in whole or in part, be reprinted or copied without the prior written consent of Kawasaki.
 5. Store this manual with care and keep it available for use at any time. If the robot is reinstalled or moved to a different site or sold off to a different user, attach this manual to the robot without fail. In the event the manual is lost or damaged severely, contact Kawasaki.

Applicable Robots

This manual is applicable to MG Series (Ver. B) robots. Check the position of the JT3 mechanical stopper and the machine nameplate to know if the robot is MG Series (Ver. B) or not.

MG series (Ver. B) robot

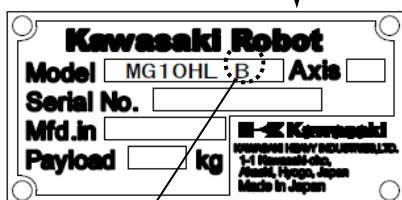
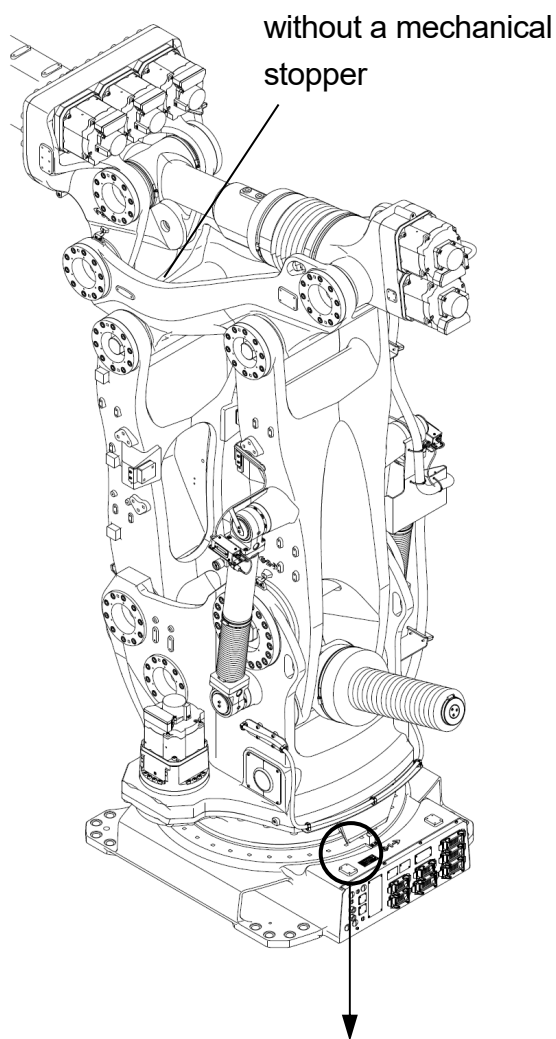

“B” is written in the Model column.

MG series (Ver. A) robot

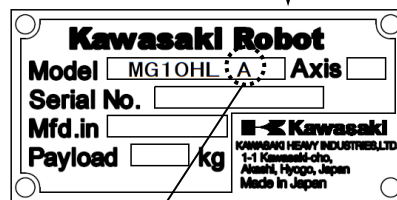
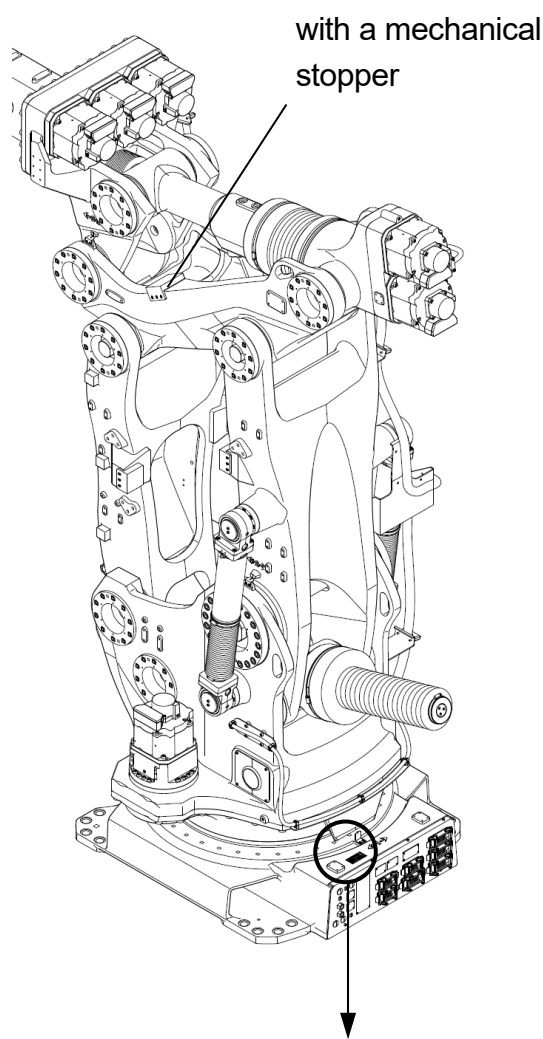

“A” is written in the Model column.

Symbols

The items that require special attention in this manual are designated with the following symbols.

Ensure proper and safe operation of the robot and prevent physical injury or property damages by complying with the safety matters given in the boxes with these symbols.

 **DANGER**

Failure to comply with indicated matters can result in imminent injury or death.

 **WARNING**

Failure to comply with indicated matters may possibly lead to injury or death.

 **CAUTION**

Failure to comply with indicated matters may lead to physical injury and/or mechanical damage.

[NOTE]

Denotes precautions regarding robot specification, handling, teaching, operation, and maintenance.

 **WARNING**

- 1. The accuracy and effectiveness of the diagrams, procedures, and detail explanations given in this manual cannot be confirmed with absolute certainty. Accordingly, it is necessary to give one's fullest attention when using this manual to perform any work. Should any unexplained questions or problems arise, please contact Kawasaki.**
- 2. Safety related contents described in this manual apply to each individual work and not to all robot work. In order to perform every work in safety, read and fully understand the "Safety Manual," all pertinent laws, regulations and related materials as well as all the safety explanation described in each chapter, and prepare safety measures suitable for actual work.**

Table of Contents

Preface	i
Applicable Robots	ii
Symbols	iii
1 Precautions.....	1
1.1 Precautions during Transportation, Installation and Storage.....	1
1.2 Installing Environment of Robot Arm.....	2
1.3 Residual Risks during Work.....	3
2 Work Flow at Arm Installation and Connection.....	5
3 Motion Range and Specifications of Robot.....	6
3.1 Determination of Safety Fence Installation Location.....	6
3.2 Motion Range and Specifications of Robot.....	7
3.3 Mechanical Stoppers.....	10
3.3.1 JT1 Stopper Block	11
4 Robot Transportation Method.....	12
4.1 Using a Transporting Stand	12
4.1.1 Using Wire Sling	15
4.1.2 Using Forklift.....	18
4.2 When Transporting only Arm.....	20
4.2.1 Using Wire Sling	24
4.2.1.1 When Wiring on Arm Directly with the Arm Folded.....	25
4.2.1.2 When Using Suspending Jig in Forward-Bent Posture of the Arm.....	26
4.2.2 Using Forklift.....	27
5 Installation Dimensions of Base Section	28
6 Movement Reaction Acting on Installation Surface during Operation	29
7 Installation Method.....	30
7.1 When Installing the Base Directly on the Floor	30
7.2 When Installing the Robot Base Plate on the Floor.....	30
7.3 Checking Gas Spring Pressure after Installation	31
8 Mounting of Tools	33
8.1 Dimensions of Wrist End (Flange Surface).....	33
8.2 Specification of Mounting Bolt	34
8.3 Load Capacity and JT3 Maximum Motion Range Limits.....	35
9 Mounting External Equipment	38
9.1 Service Tapped Hole Positions.....	38
10 JT2 Stop/Storage Posture.....	39

1 Precautions

1.1 Precautions during Transportation, Installation and Storage

When transporting the Kawasaki Robot to its installation site, strictly observe the following cautions.



WARNING

1. When the robot arm is to be transported by using a crane or forklift, never support the robot arm manually.
2. During transportation, never climb on the robot arm or stay under the suspended robot arm.
3. Prior to installation, turn OFF the controller power switch and the external power switch for shutting down power supply to the controller. Display signs indicating clearly “Installation and connection in progress”, and lock out/tag out the external power switch to prevent accidents of electric shock etc. caused when someone accidentally turns ON the power.
4. Prior to moving the robot, ensure safety by first confirming no abnormality is observed in installing condition, etc., and then turn ON the motor power to set the robot to the desired pose. Be careful not to be caught by/between any moving parts due to careless approach to the robot. After setting the robot to the specified pose, turn OFF the controller power and the external power switch again as mentioned above. Display signs indicating clearly “Installation and connection in progress”, and lock out/tag out the external power switch before starting installation and connection.
5. When it is necessary to change the arm pose during transportation and installation, see “4 Robot Transportation Method.”



CAUTION

1. Since the robot arm is composed of precision parts, be careful not to apply excessive shocks or vibrations during transportation.
2. Prior to installation, remove all obstacles so the installation is carried out smoothly and safely. Clear a passage to the installation area for transportation of the robot arm.
3. During transportation and storage,
 - (1) Keep the ambient temperature within the range of minus 10 to 60°C.
 - (2) Keep the relative humidity within the range of 35 to 85% RH without dew condensation.
 - (3) Keep free from excessively strong vibration.

1.2 Installing Environment of Robot Arm

The robot arm must be installed in a place that satisfies all the following environmental conditions:

1. When the robot is installed on the floor, the levelness must be within $\pm 5^\circ$.
2. Be sure that the installation floor or pedestal has sufficient rigidity.
3. Secure a flatness to prevent undue force applied to the installation section. (If sufficient flatness is unobtainable, insert liners and adjust the flatness.)
4. Keep the ambient temperature during operation within the range of 0 to 45°C. (Deviation or overload error may occur due to high viscosity of grease or oil when starting operation at low temperatures. In this case, move the robot at low speed before operation.)
5. Keep the relative humidity during operation within the range of 35 to 85%RH without dew condensation.
6. The robot installing place should be free from dust, dirt, oil, smoke, water, and other foreign matters.
7. The robot installing place should be free from flammable or corrosive liquid or gas.
8. The robot installing place should be free from excessively strong vibration. (0.5G or less)
9. The robot installing place should be free from electric noise interference.
10. The robot installing place should be sufficiently larger than the motion range of robot arm.
 - (1) Install a safety fence so the maximum movement of fully equipped robot arm (with tools and workpieces) does not cause interference.
 - (2) Minimize the number of entrance gates (only one is best) and equip the entrance gate with a safety plug.
 - (3) Observe the requirements of ISO 10218 established in each region for details of the safety fence.

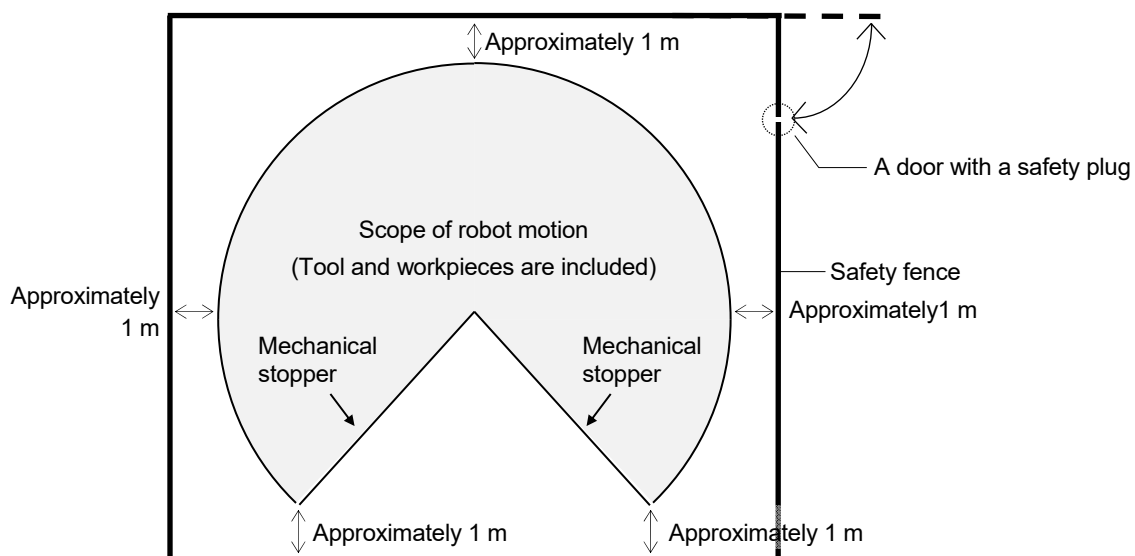

1.3 Residual Risks during Work

! **WARNING**

Pay attention to the hazardous places listed in the drawings below.

High-temperature and electric shock danger areas

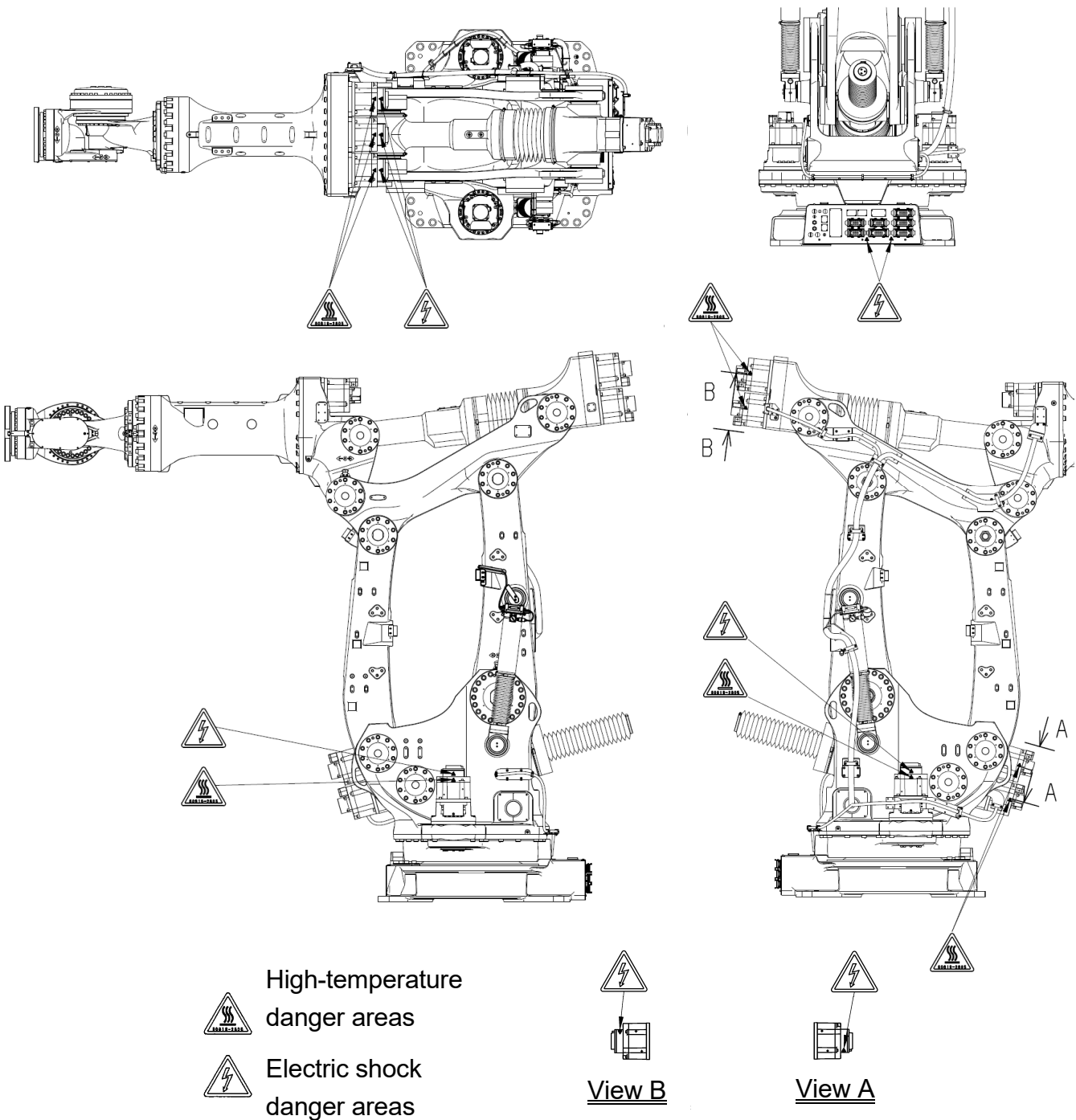

Catching danger areas

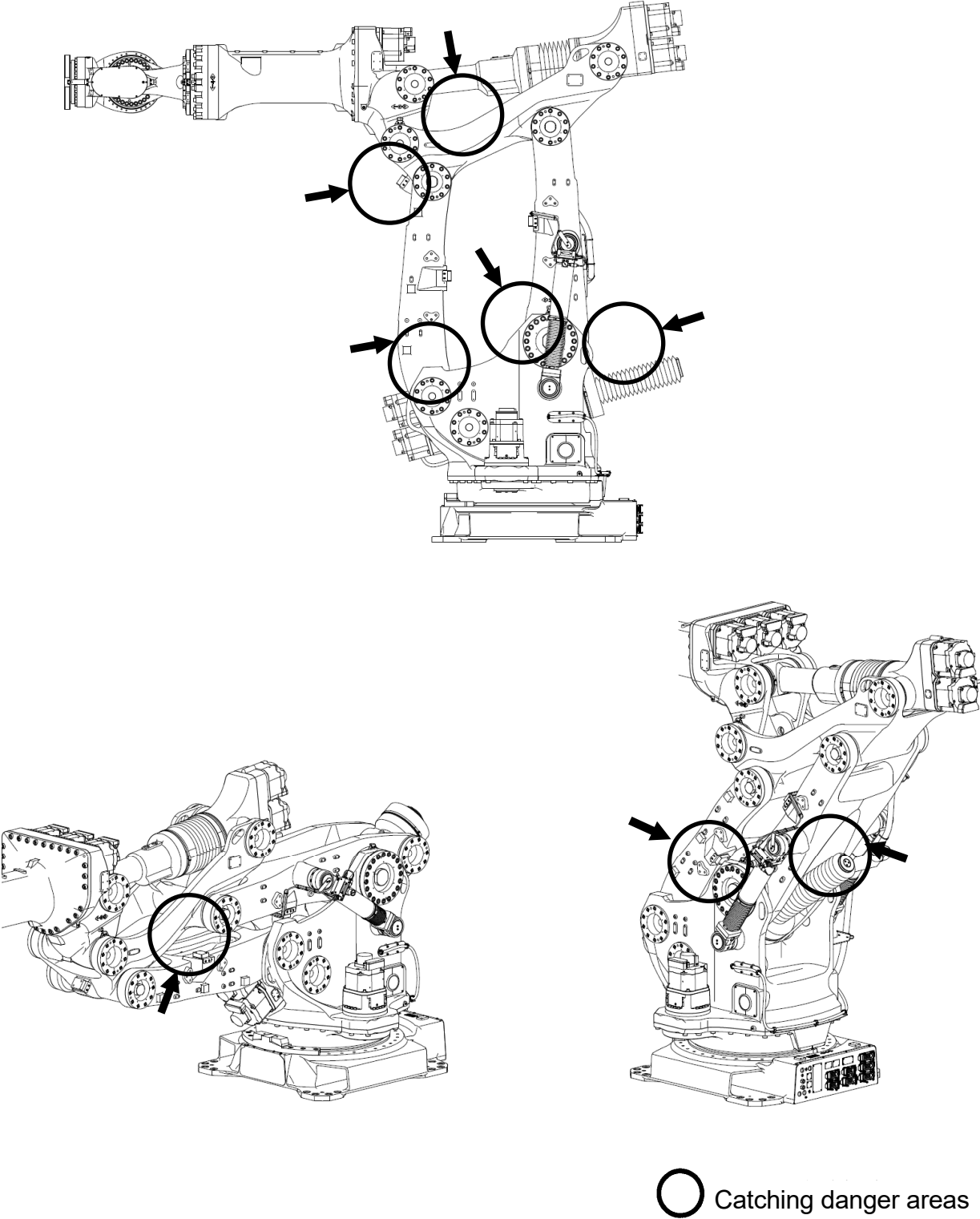

2 Work Flow at Arm Installation and Connection

This workflow describes only the robot arm section. For the controller, refer to “Installation and Connection Manual” for controller.

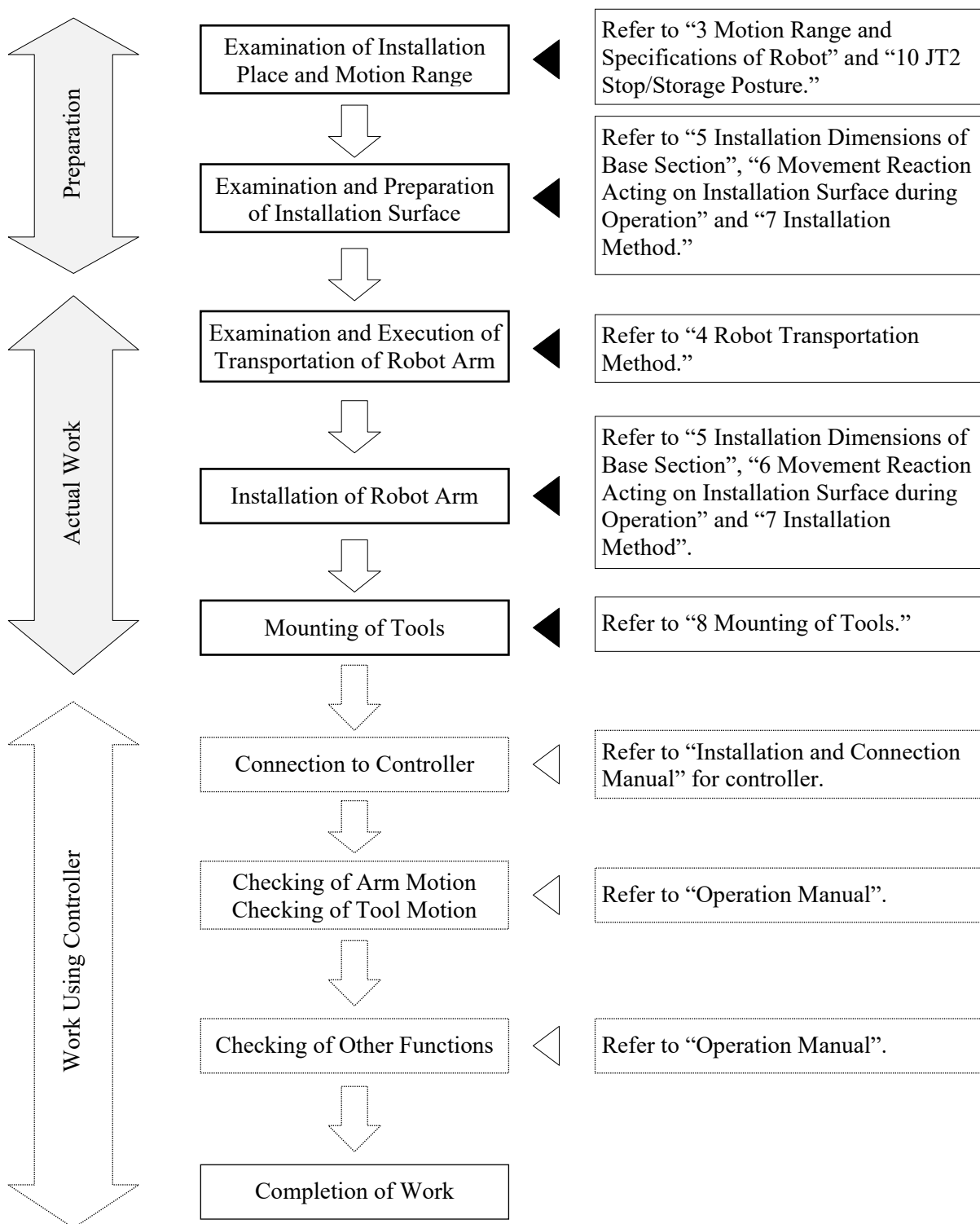

3 Motion Range and Specifications of Robot

3.1 Determination of Safety Fence Installation Location

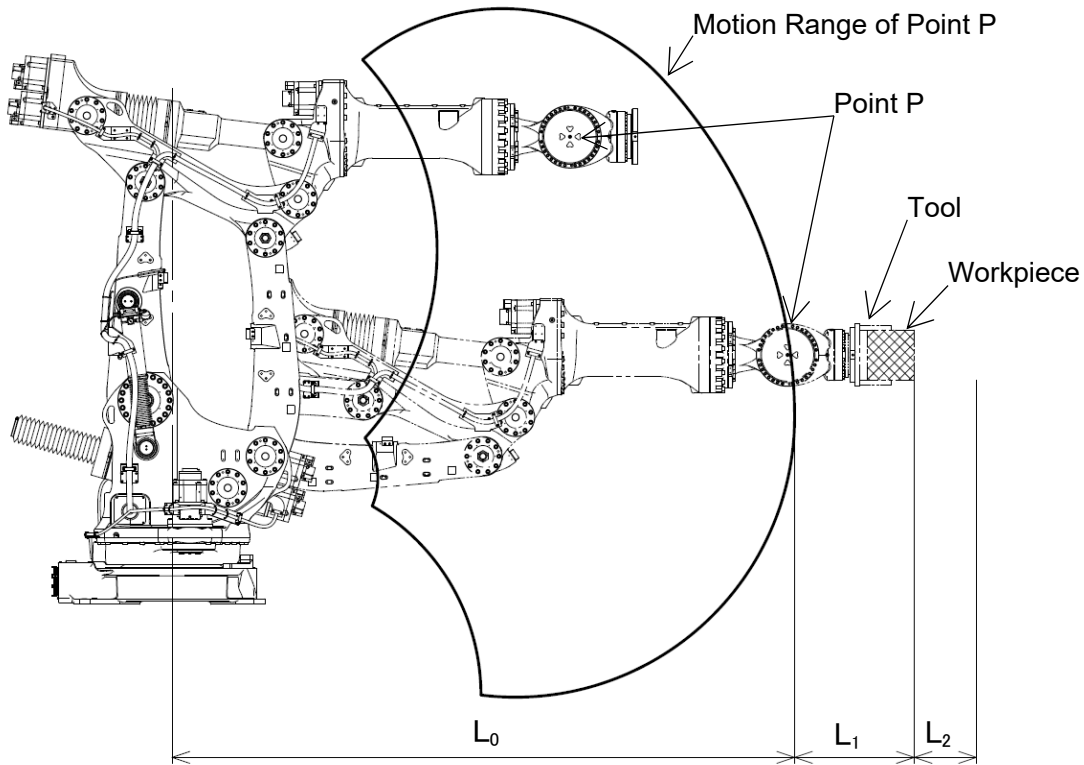

The motion range of the robot is represented by the maximum area that can be covered by point P in the figure above. Therefore, as shown in the figure below, install the safety fence outside circle whose radius is $L_0+L_1+L_2$. Where L_0 is the length from the center line of arm (point A shown above) to the farthest point of P, L_1 is the length from point P to the farthest point of wrist flange, tool and workpiece, and L_2 is safety margin. For the length of L_0 , refer to the drawings in the section “3.2 Motion Range and Specifications of Robot.”

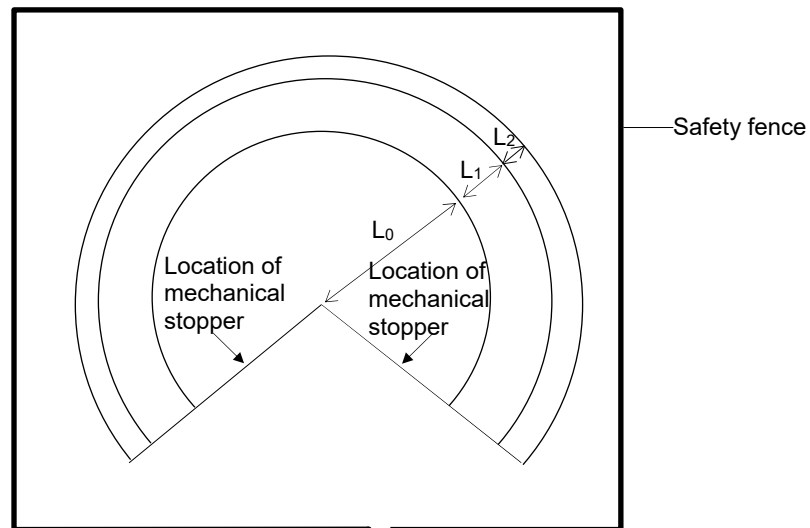

3.2 Motion Range and Specifications of Robot

MG10HL

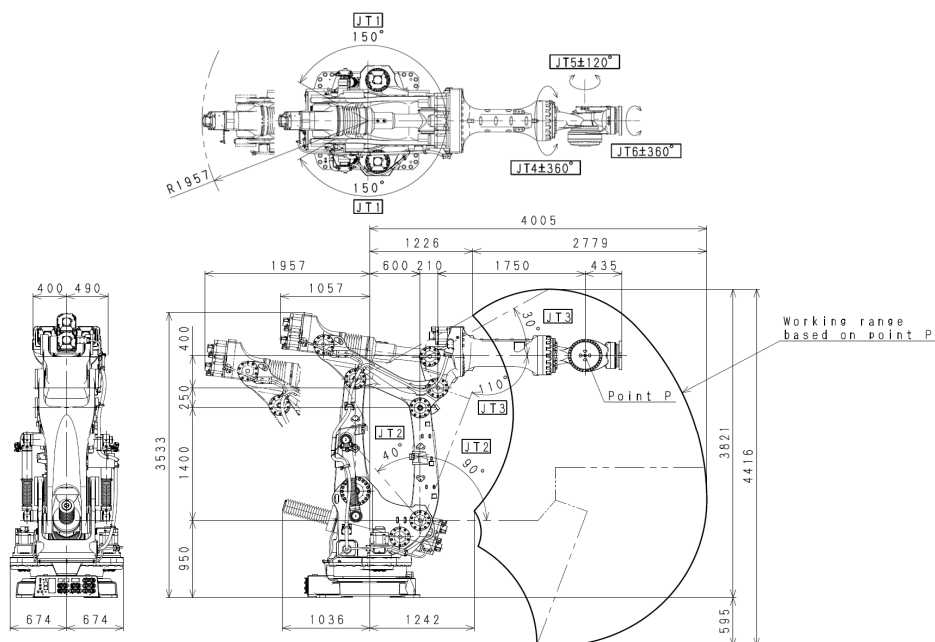

Type	Vertical Articulated Robot		
Degree of Freedom	6		
Motion Range and Maximum Speed	JT	Motion Range	Maximum Speed**
	1	±150°	65°/s
	2	+90° to -40°	33.5°/s
	3	+30° to -110°	37.5°/s
	4	±360°	65°/s
	5	±120°	65°/s
6	±360°	80°/s	
Max. Payload	1000 kg		
Wrist Load Capacity	JT	Torque	Moment of Inertia
	4	8800 N·m	1800 kg·m ²
	5	8800 N·m	1800 kg·m ²
6	4410 N·m	120 kg·m ²	
Repeatability	±0.1 mm		
Mass	6500 kg (except options)		
Acoustic Noise	76 dB (A)*		

*Measured condition:

- Equivalent to ISO 11201
- Reference operation in Kawasaki

(The acoustic noise level depends on robots, loads and operation conditions, and it may exceed 80 dB depending on the application motion such as moving a single axis at the maximum speed. Protect personnel from noise as necessary.)

**The values in the table are maximum values and vary depending on conditions such as load and motion range.

MG15HL

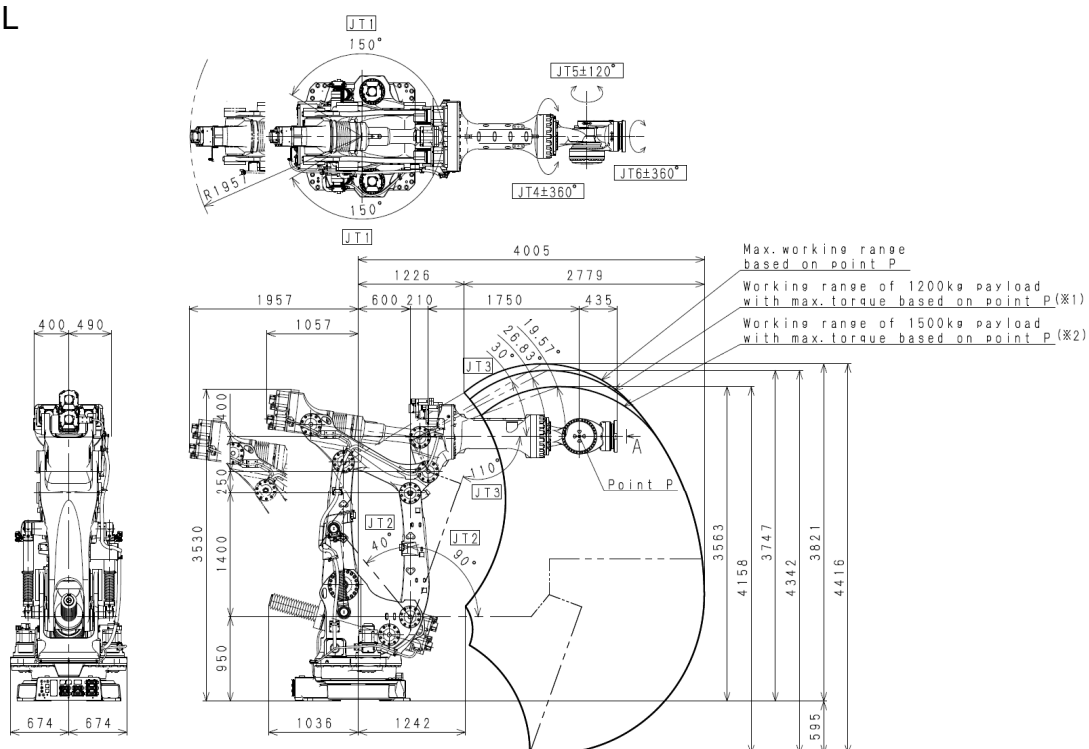

Type	Vertical Articulated Robot		
Degree of Freedom	6		
Motion Range and Maximum Speed	JT	Motion Range	Maximum Speed***
	1	±150°	65°/s
	2	+90° to -40°	33.5°/s
	3	+30°** to -110°	37.5°/s
	4	±360°	36°/s
	5	±120°	36°/s
6	±360°	80°/s	
Max. Payload	1500 kg		
Wrist Load Capacity	JT	Torque	Moment of Inertia
	4	15000 N·m	2250 kg·m ²
	5	15000 N·m	2250 kg·m ²
6	4410 N·m	1200 kg·m ²	
Repeatability	±0.1 mm		
Mass	6550 kg (except options)		
Acoustic Noise	78 dB (A)*		

* Measured condition: installed on the plate rigidly fixed on the floor
 · Equivalent to ISO 11201
 · Reference operation in Kawasaki
 (The acoustic noise level depends on robots, loads and operation conditions, and it may exceed 80 dB depending on the application motion such as moving a single axis at the maximum speed. Protect personnel from noise as necessary.)

** The motion range limit on the plus side depends on load mass and load torque. (See section 8.3 for details.)

***The values in the table are maximum values and vary depending on conditions such as load and motion range.

3.3 Mechanical Stoppers

For base axes JT1, JT2 and JT3, mechanical stoppers are mounted at the places shown in the figure below. Among them, the motion range of JT1 can be changed by adding stopper block of stopper parts on the fixed (base) side.

However, when the motion range is changed, it is necessary to change the motion range limits to the corresponding values by Auxiliary function 0507.

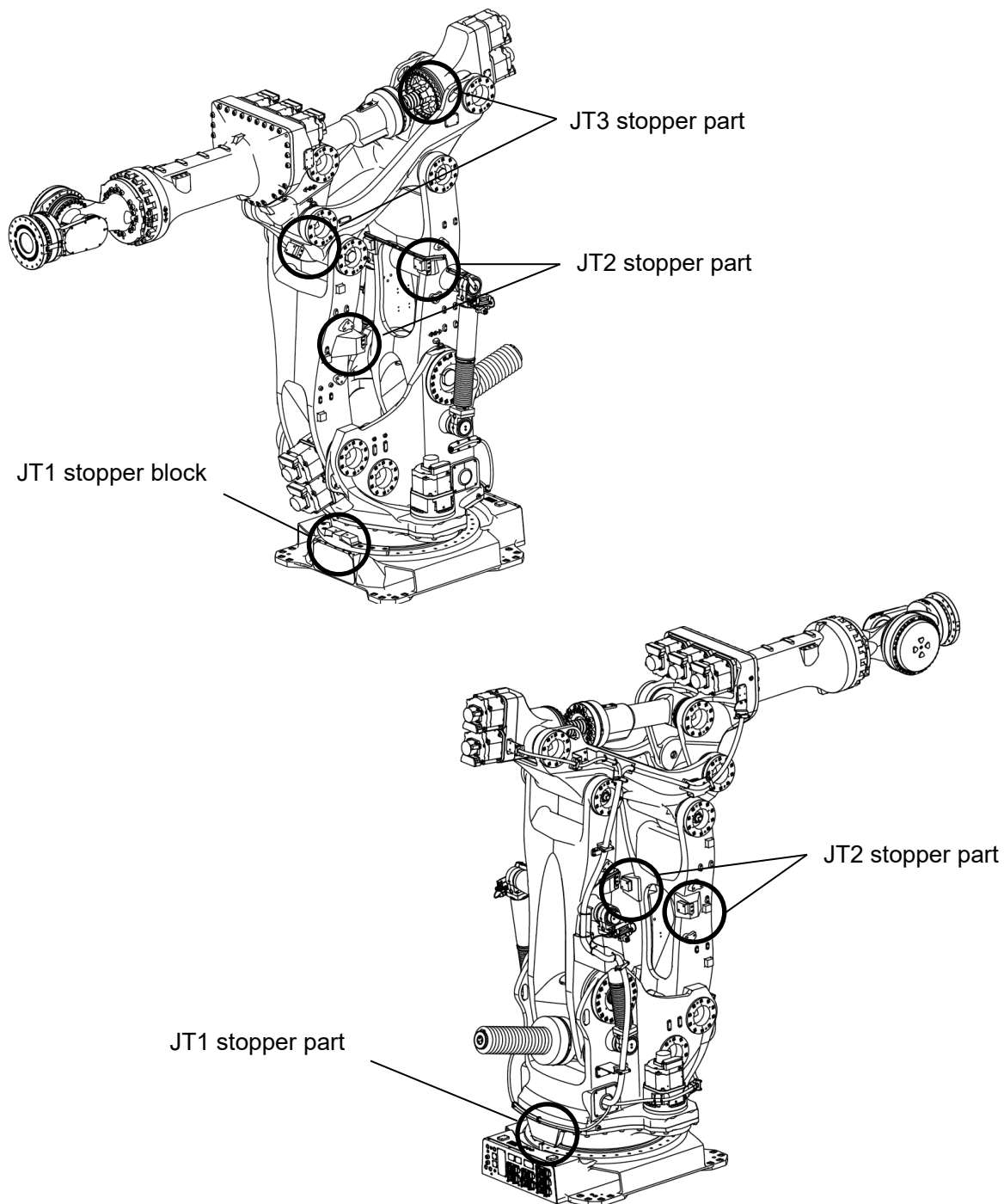

3.3.1 JT1 Stopper Block

Motion range of JT1 is 150° on the plus side and 150° on the minus side due to the restriction from control and harness treatment. However, mounting position of JT1 stopper block can be changed by angular unit of 10 degrees, and reducing the total motion range on both sides is possible between 30° and 210° by mounting two stopper blocks as an option.

Mounting two stopper blocks as shown below makes it possible to reduce the motion range to 110° on the plus side and 100° on the minus side.

! **CAUTION**

Do not change the mounting position when mounting a stopper block because the motion range on plus (or minus) side exceeds 150° if the mounting position is changed.

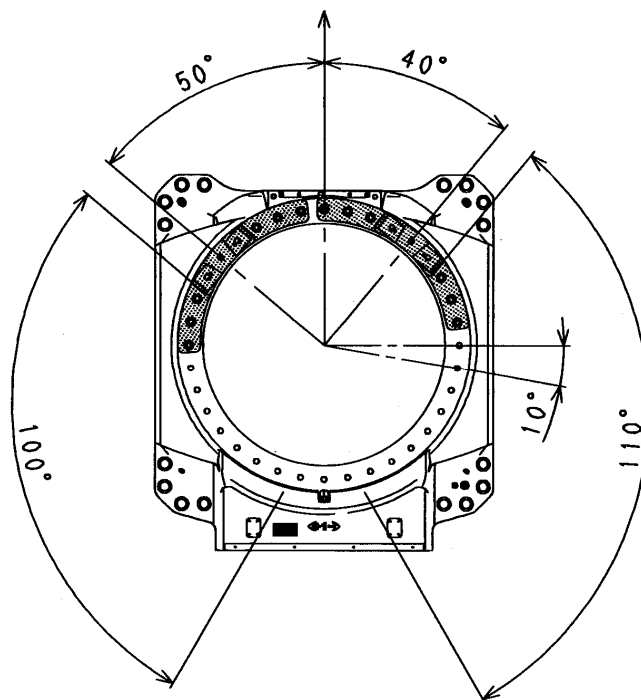

4 Robot Transportation Method

The robot can be transported by the following two methods: using a crane or a forklift. The procedures differ for when a transporting stand is used or when only the arm is transported without the stand.

4.1 Using a Transporting Stand

The arm is delivered on a transporting stand as shown in the figure below.

There are two types of transporting stands. For the forms, refer to the figure below.

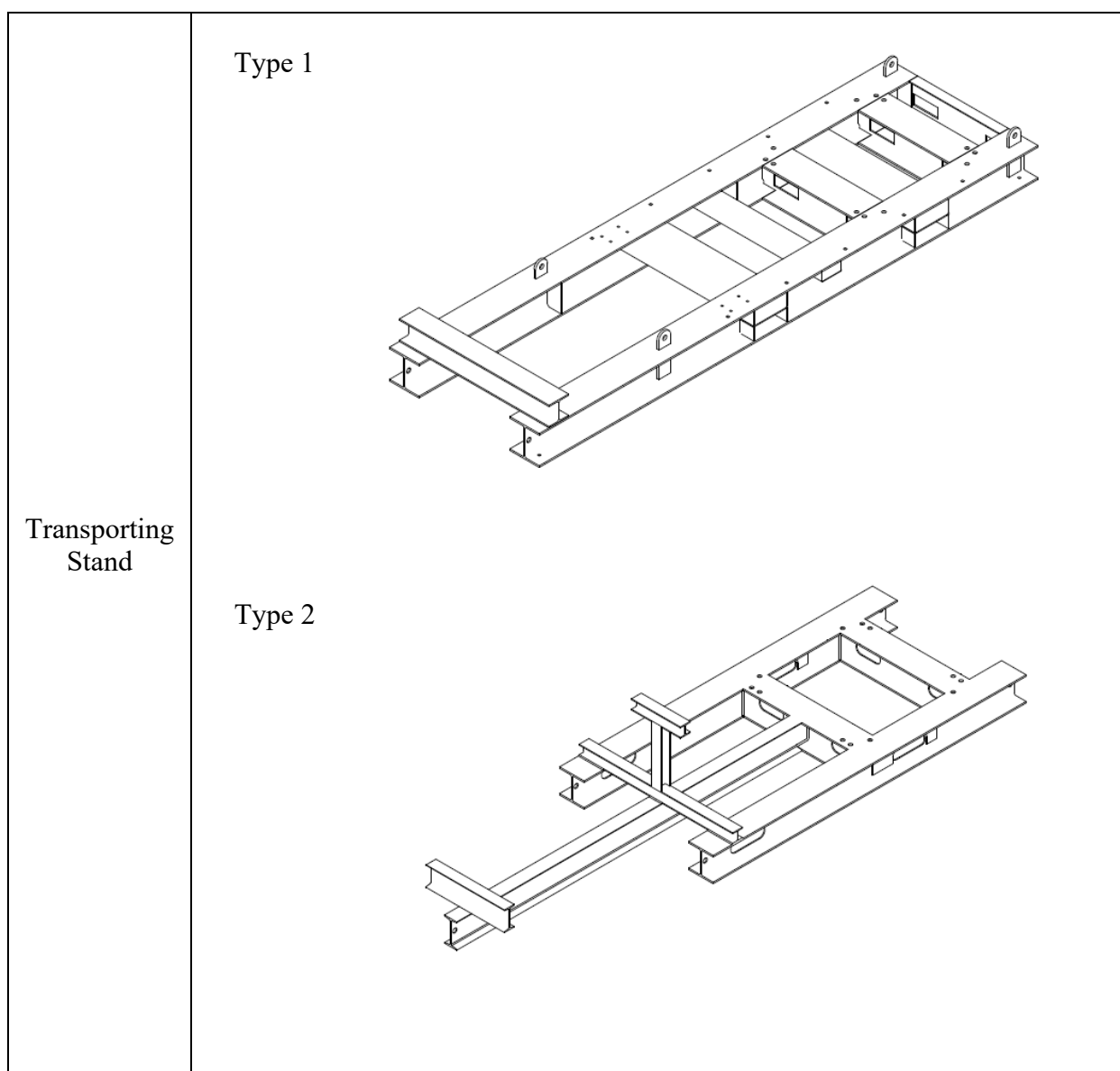

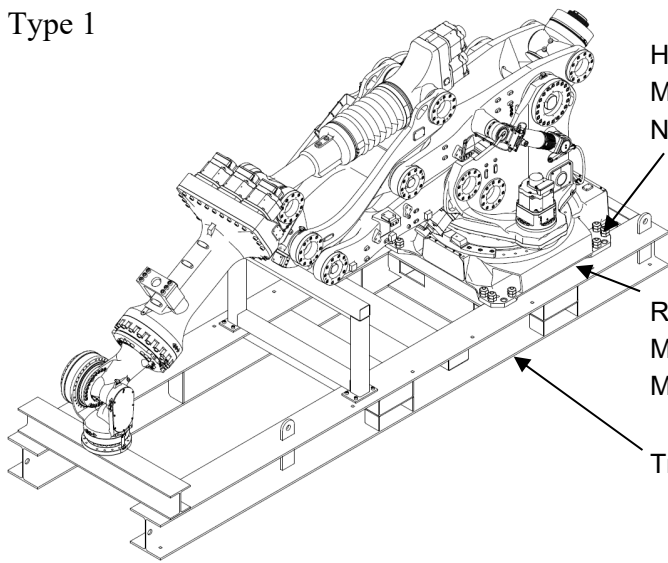
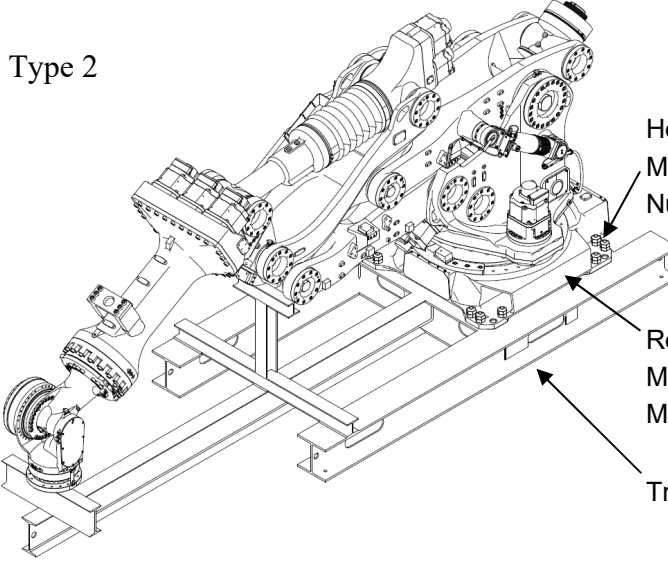
Posture when delivered	Type 1	 <p>Hexagon socket head bolt M30x110L (12 pcs) Nut: two nuts each for M30 (16 pcs)</p> <p>Robot arm MG10HL: 6500 kg (except options) MG15HL: 6550 kg (except options)</p> <p>Transporting stand: 1600 kg</p>
	Type 2	 <p>Hexagon socket head bolt M30x110L (12 pcs) Nut: two nuts each for M30 (16 pcs)</p> <p>Robot arm MG10HL: 6500 kg (except options) MG15HL: 6550 kg (except options)</p> <p>Transporting stand: 830 kg</p>
	JT1	0°
	JT2	90°
	JT3	-30°
	JT4	0°
	JT5	-60°
	JT6	0°

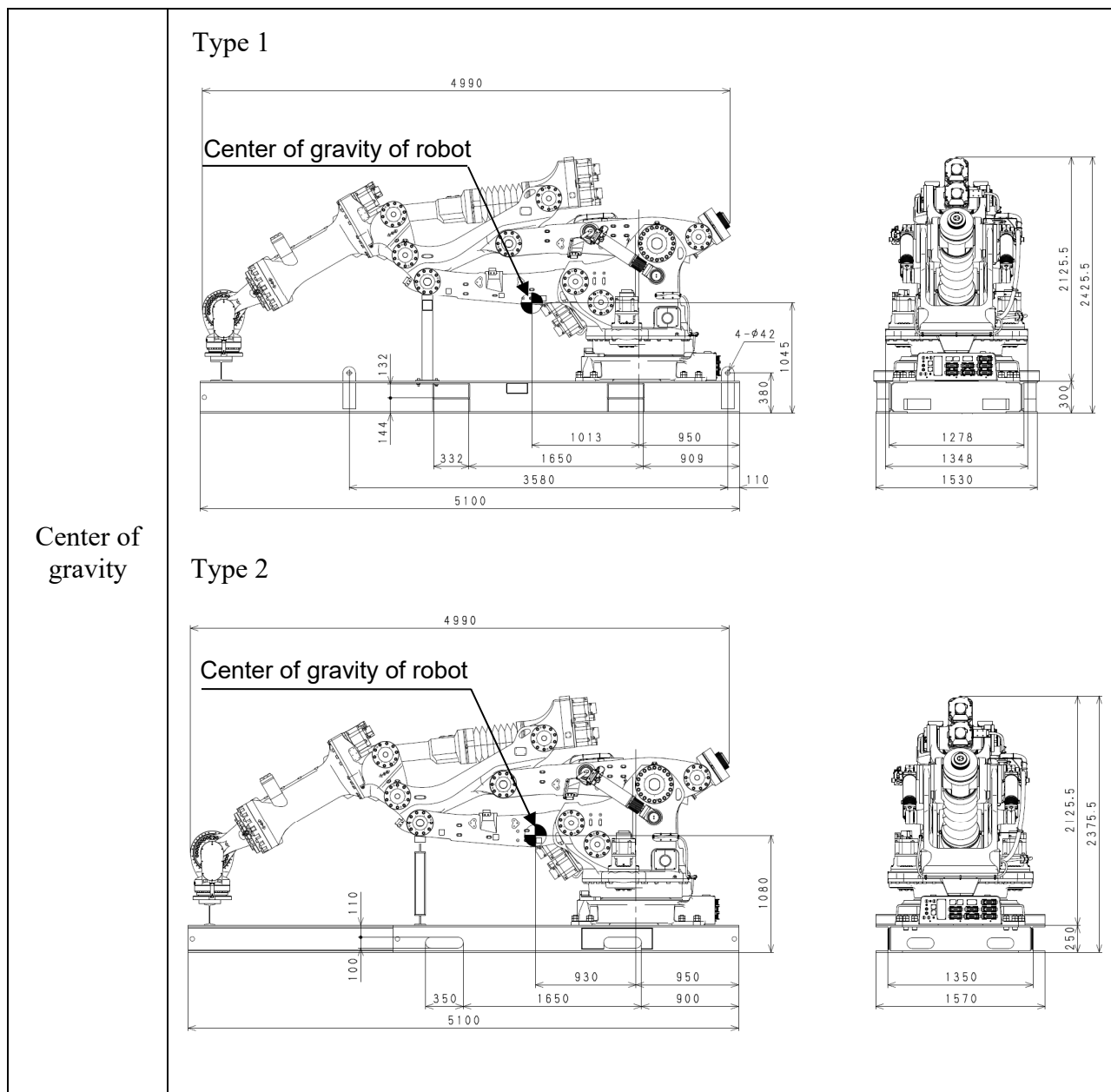

4.1.1 Using Wire Sling

1. When transporting a robot using a crane, suspend up the robot with wire by hanging hooks to the four points of the transporting stand as shown in Type 1 on the next page. For Type 2, mount a suspending jig (60154-6675) on the upper arm and suspend up the robot by hanging hooks to four points of the arm and a point of the jig. After suspending up, remove the suspending jig.



WARNING

1. Use wire slings with proper length to distribute the load to all slings without slack of the wire slings.
2. When suspending up the robot, recognize the gravity center and be careful so that the arm does not fall during suspending and transporting.
3. The suspending method depends on the type of transportation stands. Check the transportation form shown in section 4.1 to suspend up the robot.
4. For Type 2, do not suspend up the transportation stand directly while the robot is loaded.



CAUTION

1. When suspending up the robot, do not suspend up the robot with wire slings touching ball screws or motors to avoid early damage on the ball screws and the motors.
2. When suspending up the robot, be careful as robot may lean forward/backward depending on the robot posture and installation condition of the options. If the robot is suspended up in an inclined posture, it may swing, damage or the wire may interfere with the harness, piping etc., or it may damage due to interfering with surrounding objects.
3. Remove the wire slings attached to the arm once the transportation of robot is complete.
4. When using wires, do not suspend up the robot other than at the specified positions.

Suspended posture

Type 1

Wire (4 pcs)

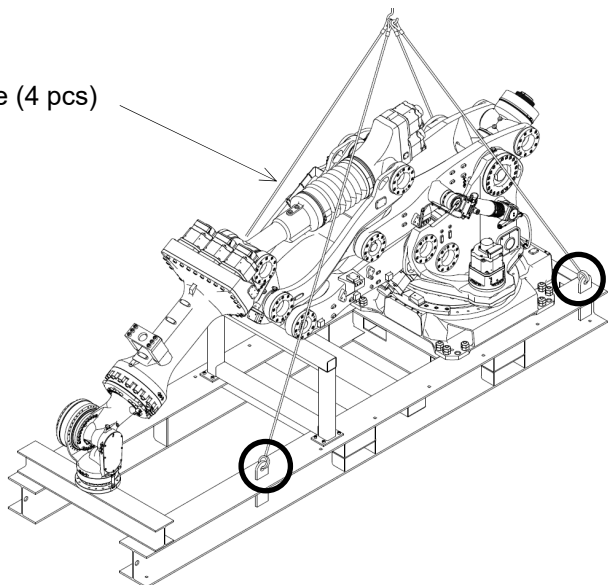

Type 2

Wire (5 pcs)

Hexagon socket head bolt M20×230 (6 pcs)

Tightening torque: 431.2 N·m

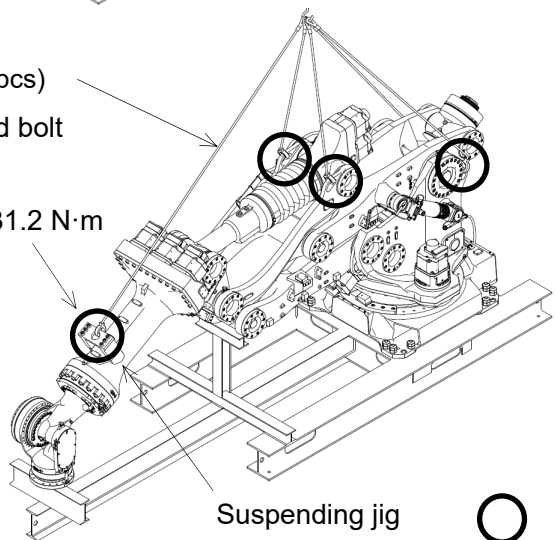

Suspending jig

Suspending point

JT1	0°
JT2	90°
JT3	-30°
JT4	0°
JT5	-60°
JT6	0°

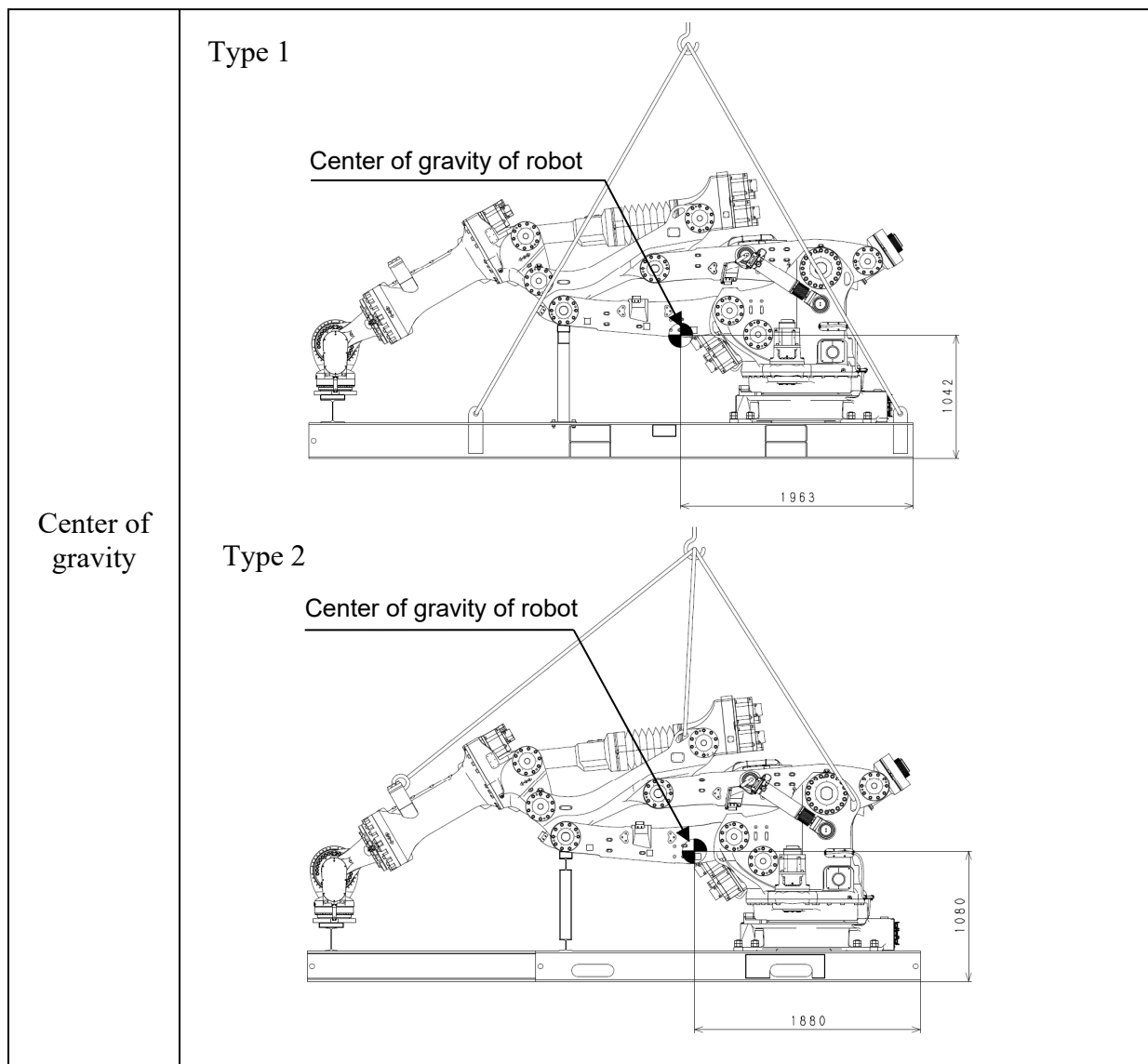

2. The arm should be detached from the transporting stand during installation. (See section 4.2.)

4.1.2 Using Forklift

1. When using a forklift, transport the robot by using the forklift pocket on the transporting stand as shown below.

⚠ CAUTION

1. Check if a fork of the forklift penetrates the forklift pocket sufficiently without fail.
2. When transporting the robot on an inclined or rough surface, be careful to maintain balance to prevent the forklift/robot from falling.

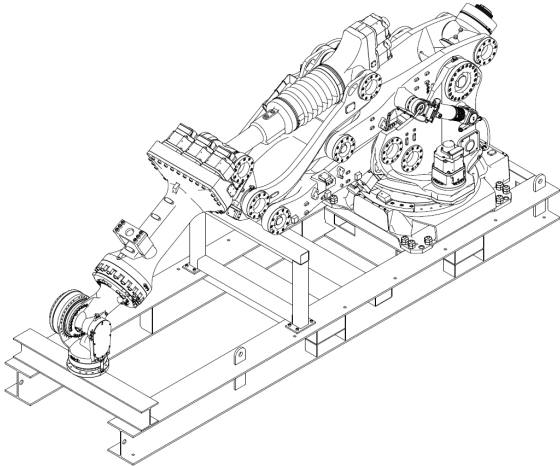
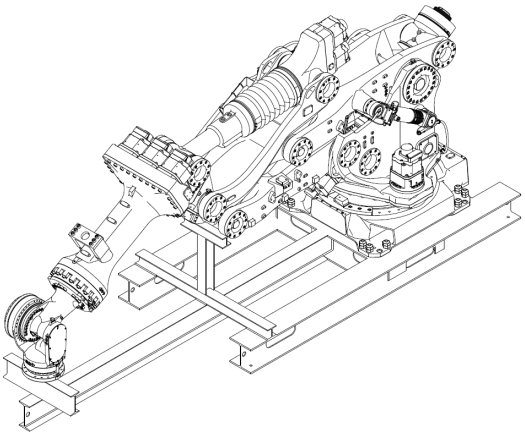
Transported posture	Type 1		
	Type 2		
	JT1		0°
	JT2		90°
	JT3		-30°
	JT4		0°
	JT5		-60°
	JT6		0°

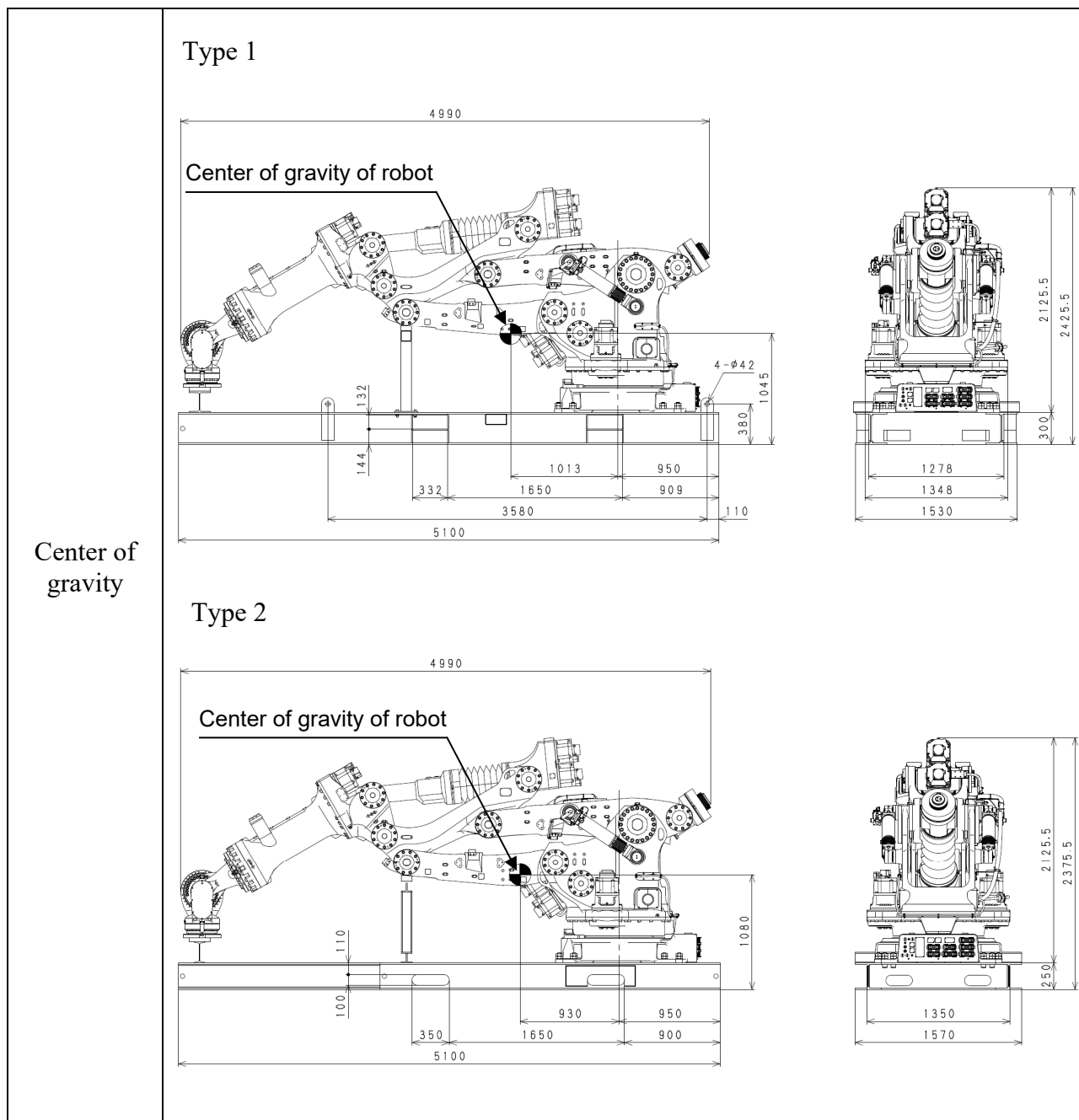

2. The arm should be detached from the transporting stand during installation. (See section 4.2.)

4.2 When Transporting only Arm

Only the arm detached from the transporting stand is transported to the installation place.



WARNING

1. When transporting the arm by wire slings while keeping the delivered posture, confirm that there is no slack on the wire, and then unscrew the screws bolting the arm to the transporting stand. If there is slack on the wire, the arm may fall when the tightening screws are unscrewed. (See subsection 4.2.1.2.)
2. Take measures to prevent the third person from executing the automatic operation and/or approaching the arm before changing the arm posture on the transporting stand. Read and understand the contents of “Safety Manual” thoroughly before proceeding any work.
3. Fix the transporting stand as shown in the figure below when changing the arm posture on the transporting stand. Moreover, move each axis in Teach mode following the procedure below, with the transporting stand and arm fixed. Otherwise, the arm may interfere with the transporting stand or fall. Moving JT1 may increase the probability for the arm falling. Do not move the axis in Repeat mode because the arm may fall. Turn OFF the controller power switch and the external power switch after changing the arm posture, and then unscrew the screws bolting the arm to the transporting stand. (See subsections 4.2.1.1 and 4.2.2.)
4. Do not change the posture with a brake release switch.
5. For changing the posture during transporting, qualify only persons who have completed the special course(s) on robot operations, teaching and operations. Read the contents of “Safety Manual” and “Installation and Connection Manual” and “Operation Manual” of the controller thoroughly, and start the work.

Type 1

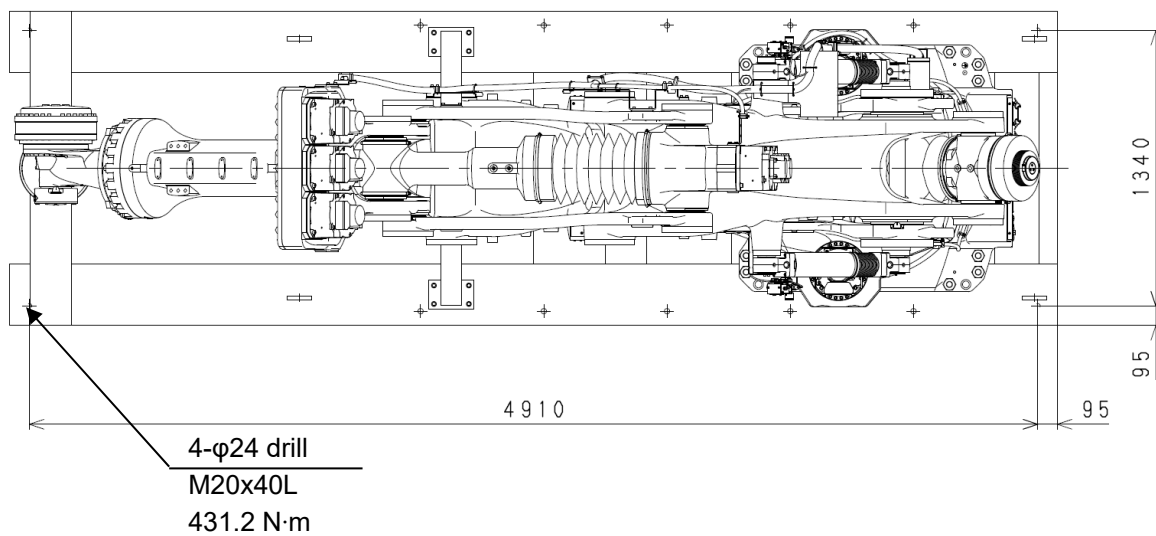

Type 2

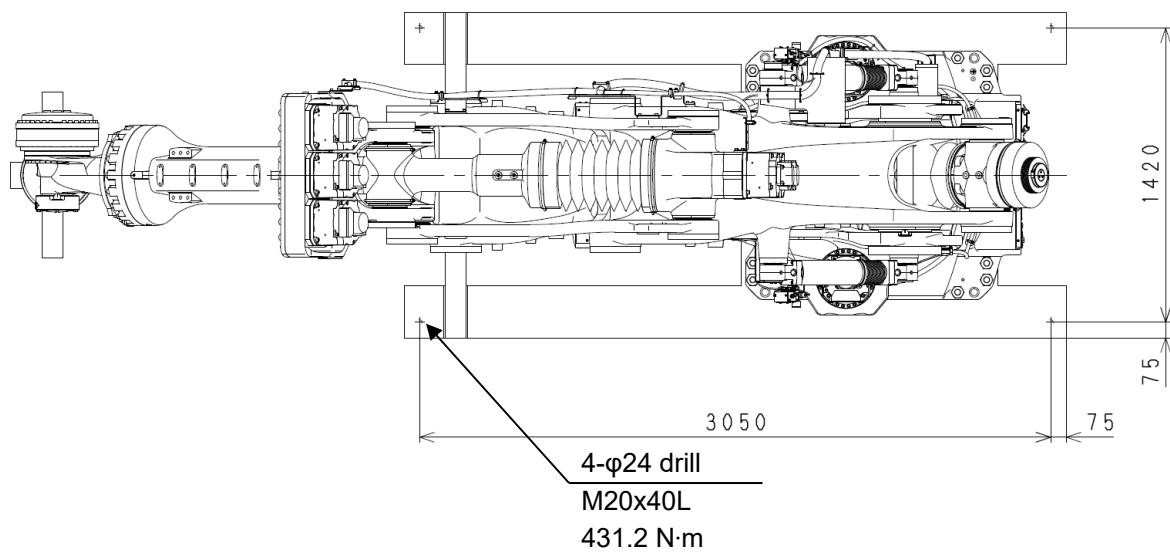

Procedure for changing postures

Refer to section 1.2 and change the arm posture in the following procedure.

1. Connect the robot arm to the controller. For details, refer to “Installation and Connection Manual” for controller.
2. Set to Teach mode and turn ON the motor power. For details, refer to “Operation Manual” for controller.
3. Make sure that Teach speed 2 is set to 10.0 mm/s on teach pendant (hereinafter called TP) screen. For details, refer to “Operation Manual” for controller.

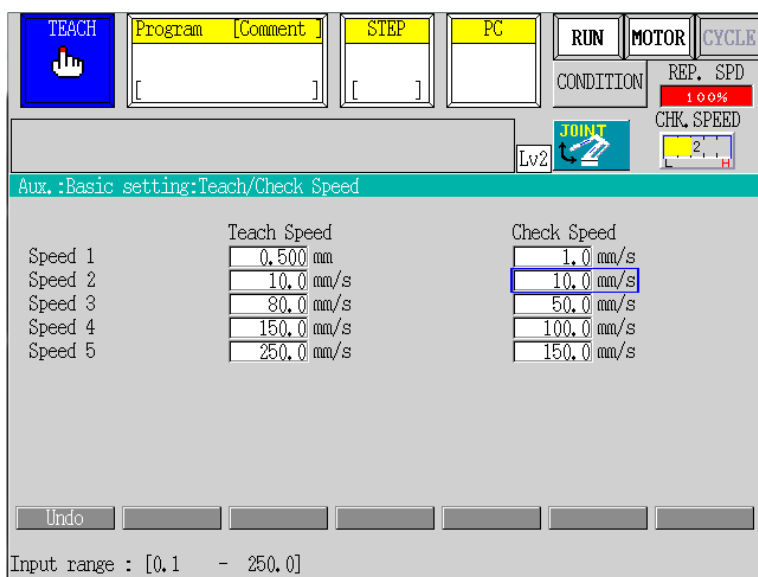

4. Display Axis data monitor on TP screen. For details, refer to “Operation Manual” for controller.

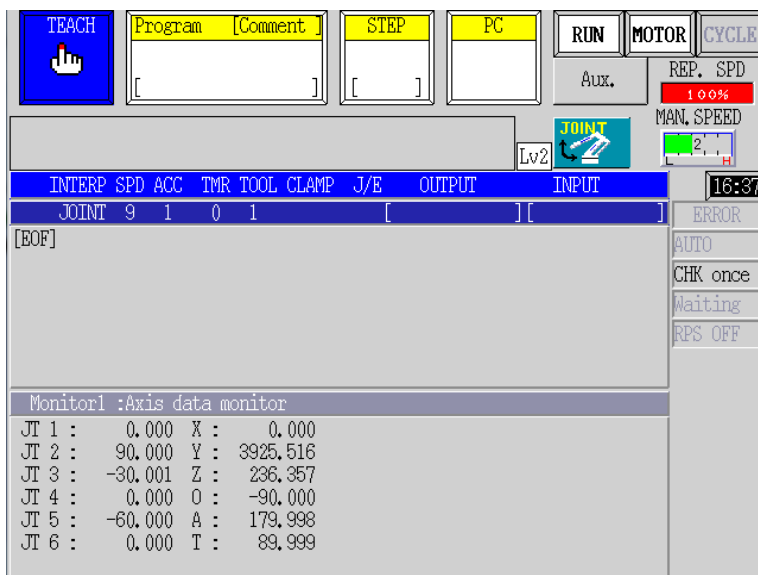

5. See the axis data on Axis data monitor screen of TP and move JT2 from 90° to -40° in Teach speed 2.*¹
6. See the axis data on Axis data monitor screen of TP and move JT5 from -60° to 0° in Teach speed 2.*¹
7. See the axis data on Axis data monitor screen of TP and move JT3 from -30° to -55° in Teach speed 2.*¹

*1 Do not move the axes other than the specified axis.

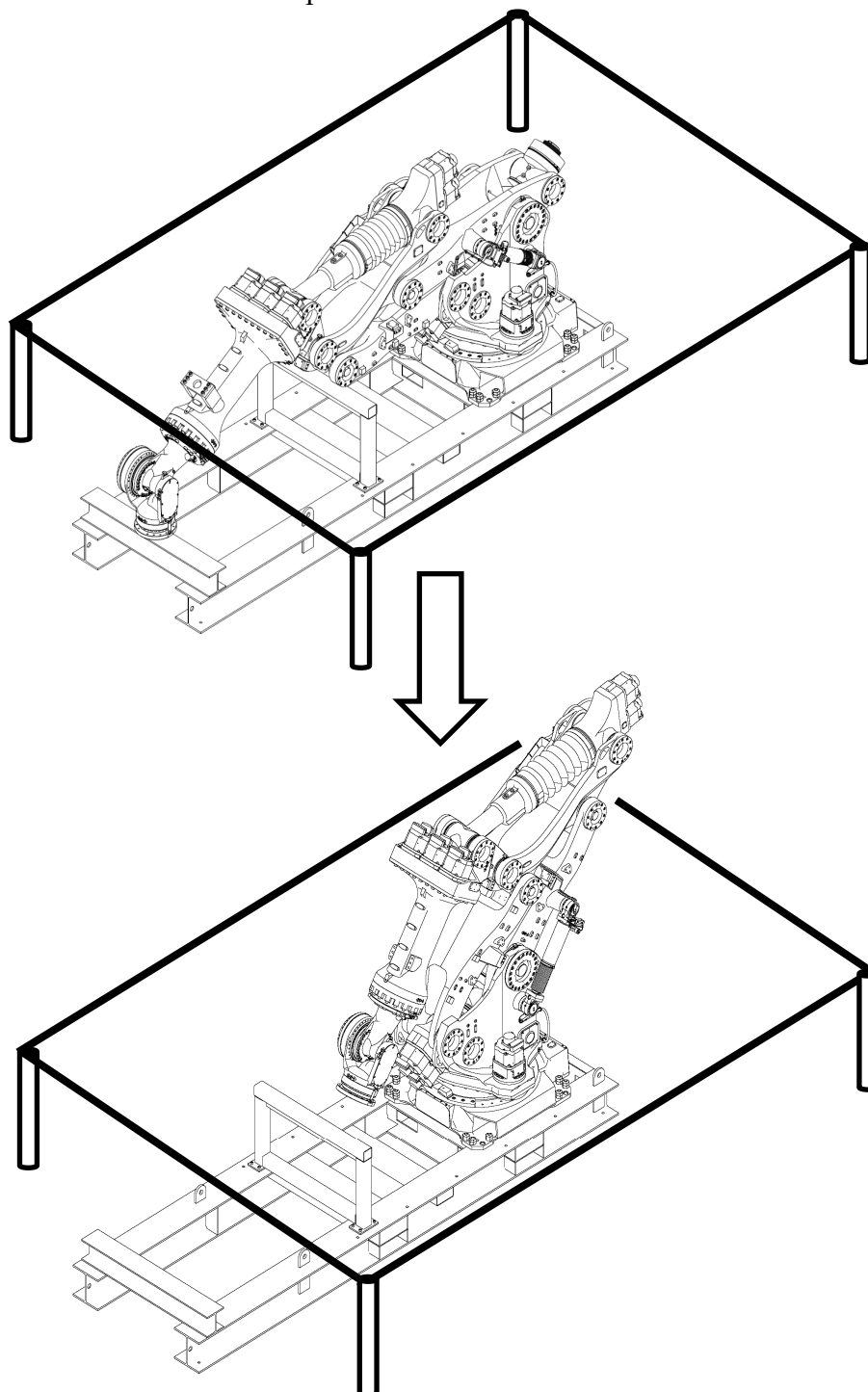

4.2.1 Using Wire Sling

Using wire slings, robot can be suspended up in two different arm poses.



WARNING

1. Use wire slings with proper length to distribute the load to all slings without slack of the wire slings.
2. When suspending up the robot, recognize the gravity center of arm and be careful so that the arm does not fall in suspending and transporting.



CAUTION

1. When suspending up the robot, do not suspend up the robot with wire slings touching ball screws or motors to avoid early damage on the ball screws and the motors.
2. When suspending up the robot, be careful as robot may lean forward/backward depending on robot posture and installation condition of the options. If the robot is suspended up in an inclined posture, it may swing, damage or the wire may interfere with the harness, piping etc., or it may damage due to interfering with surrounding objects.
3. Remove the wire slings attached to the arm once the transportation of robot is complete.
4. When using the wire slings, do not suspend up the robot other than at the specified positions.

4.2.1.1 When Wiring on Arm Directly with the Arm Folded

As shown in the figure below, suspend up the robot by hanging hooks to the six suspending points of the arm.

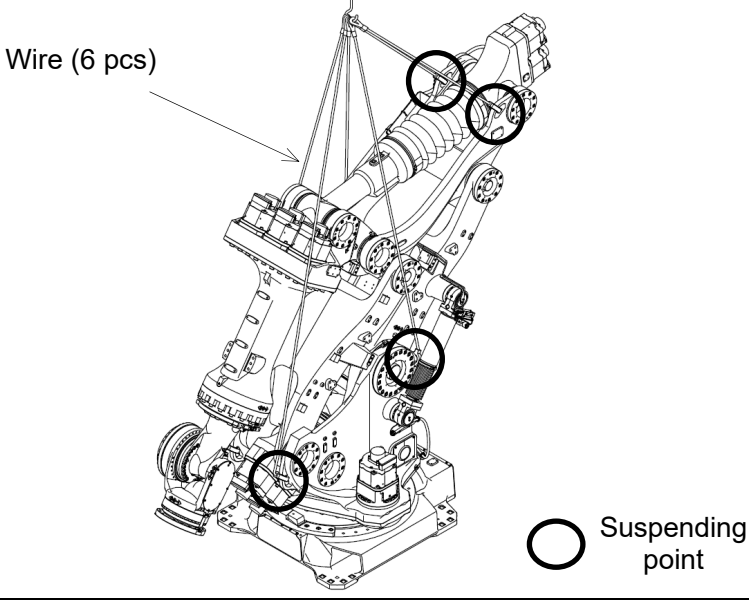
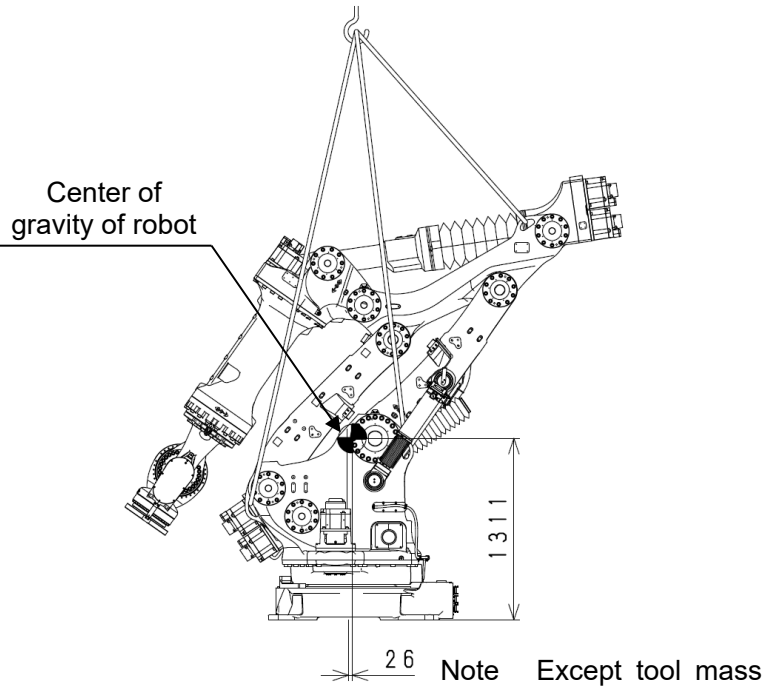
Model		MG10HL, MG15HL	
Suspended posture			
Suspended posture	JT1	0°	
	JT2	-40°	
	JT3	-55°	
	JT4	0°	
	JT5	0°	
	JT6	0°	
Center of gravity			

4.2.1.2 When Using Suspending Jig in Forward-Bent Posture of the Arm

As shown in the figure below, attach a suspending jig (60154-6675) on the upper arm and suspend up the robot by hanging hooks to the four suspending points of the arm and a point of the jig. After suspending up, remove the suspending jig.

Model	MG10HL, MG15HL	
Suspended posture		
	JT1	0°
	JT2	90°
	JT3	-30°
	JT4	0°
	JT5	-60°
	JT6	0°
Center of gravity		

⚠ WARNING

Use a suspending jig without fail when suspending up the robot in the posture shown in the figure above. If the robot is suspended up without using the jig, robot may fall.

4.2.2 Using Forklift

Transport the robot by using a forklift pocket on the base section as shown below.

⚠ CAUTION

1. Check if a fork of the forklift penetrates the forklift pocket sufficiently without fail.
2. When transporting robot on an inclined or rough surface, be careful to maintain balance to prevent forklift/robot from falling.

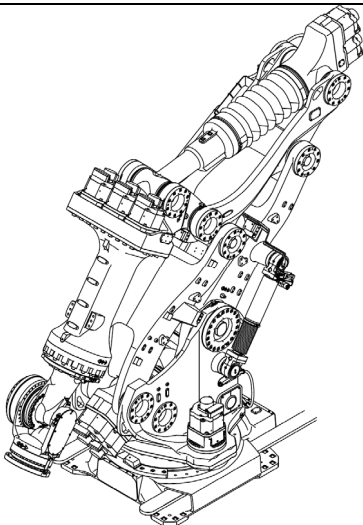
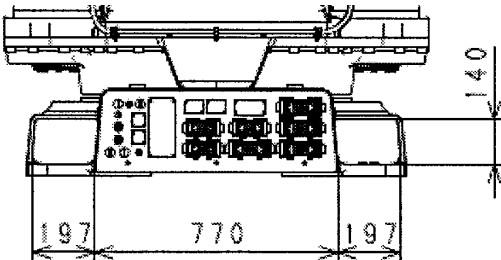
Transported posture		
Details of transported posture	JT1	0°
	JT2	-40°
	JT3	-55°
	JT4	0°
	JT5	0°
	JT6	0°
Fork pocket dimensions		

⚠ WARNING

Use a suspending jig without fail when suspending up robot. If the robot is suspended up without using the jig, robot may fall.

5 Installation Dimensions of Base Section

When installing a robot, fix the base section with high tension bolts through the bolt holes.

Model	MG10HL, MG15HL
Dimensions for installation	
Cross-section of installation section	
Bolt hole	16-φ33
High tension bolt	16-M30 Material: SCM435 Strength class: 10.9 or more.
Tightening torque	1700 N·m
Levelness	Within ±5°

6 Movement Reaction Acting on Installation Surface during Operation

Refer to the list below for the movement reaction that acts on the installation surface during operation of MG series (Ver. B) robot. Consider these values at installation.

M: Inversion Moment N·m	T: Rotating Torque N·m
160000	55000

See the next chapter for M and T.

7 Installation Method

7.1 When Installing the Base Directly on the Floor

In this case, bury the steel plate (65 mm minimum thickness) in the concrete floor as shown in the figure below or fix it with anchors. Fix the steel plate firmly enough to endure the reaction forces produced by the robot.

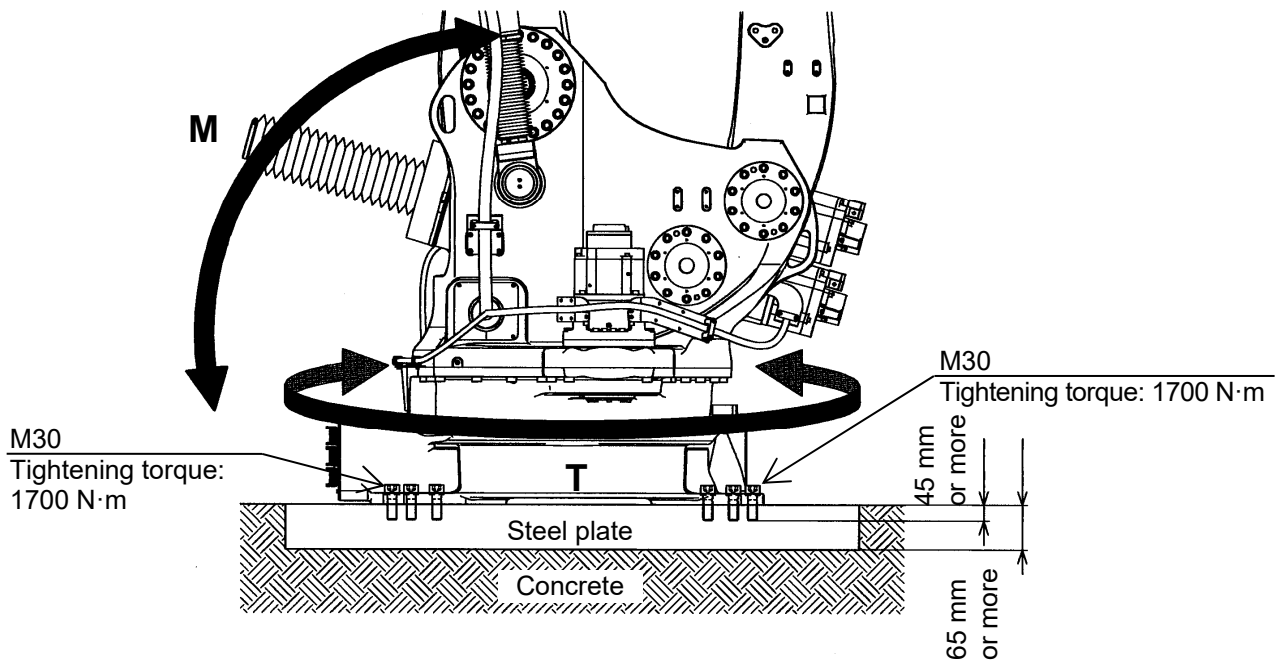

7.2 When Installing the Robot Base Plate on the Floor

In this case, install the base plate on the concrete floor or steel plate using bolt holes on the base plate. Reaction forces received from the robot are the same as when installing the base directly on the floor.

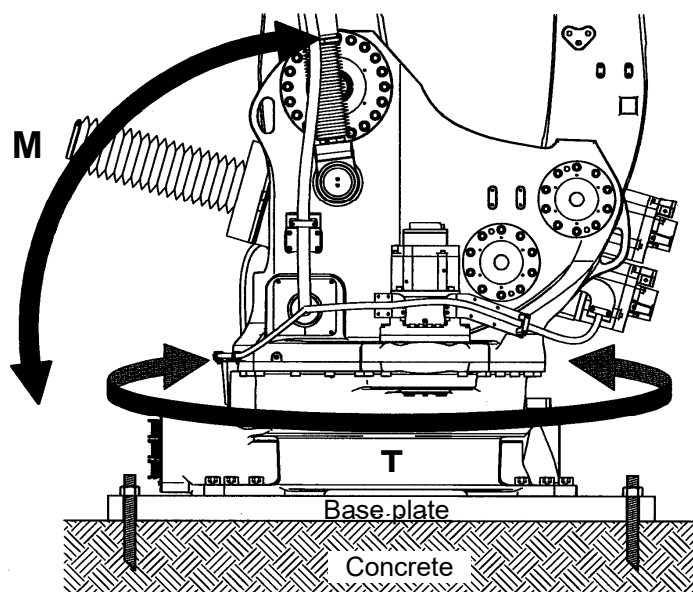

7.3 Checking Gas Spring Pressure after Installation

On the MG series (Ver.B), two gas springs are attached to JT2 on the right and left sides. A gas pressure sensor unit is installed in the gas spring to monitor the pressure.

After installing the robot arm, move the robot so that JT2 becomes $9^\circ (\pm 4^\circ)$ while checking the axis data on Axis data monitor screen of TP. Then, wait for approximately a minute and check that the pressure displayed on the monitors of the left and right gas pressure sensor units is within the range of “Rated pressure diagram of gas spring” shown on the next page.*1

*1 Refer to the figure shown below for the surface temperature check point and the positions of the monitors and gages of the gas pressure sensor units. Measure the surface temperature of the gas spring using a radiation thermometer (HORIBA, model: IT540-W or equivalent). If a radiation thermometer is not available, measure the installation environment temperature, instead of the surface temperature of the gas spring.

If the gas pressure is not within the range of the rated pressure diagram, discharge or replenish gas, referring to the “Inspection and Maintenance Manual.”

Check that the difference between the pressure displayed on the monitor and that displayed on the gage is within 1 MPa.

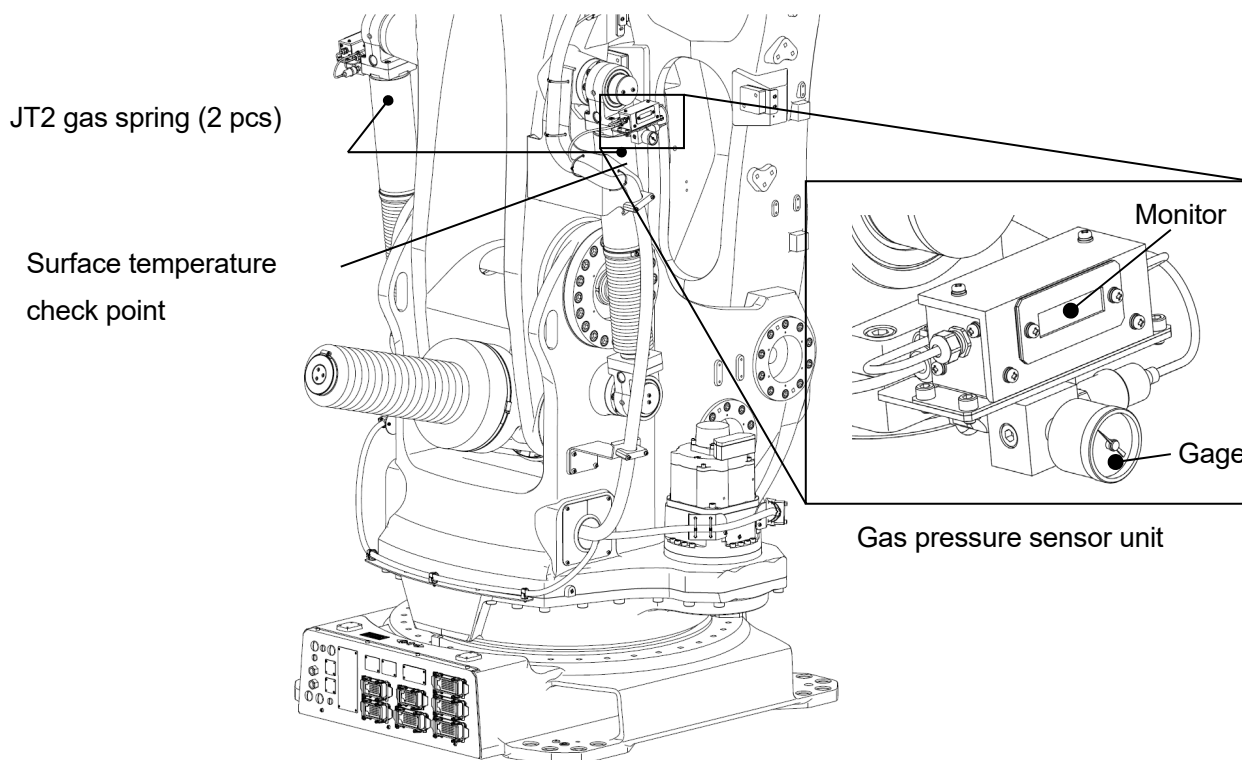

Rated pressure diagram of gas spring

See the figure below for the rated pressure of gas spring.

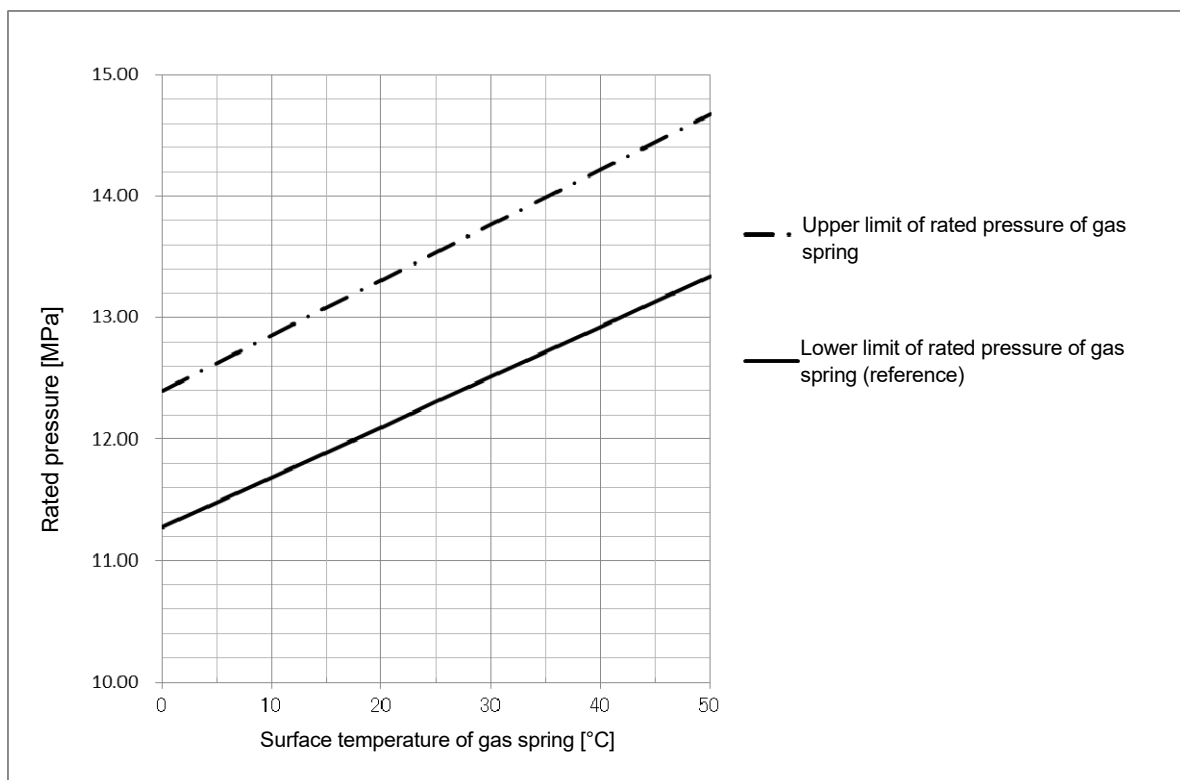

Note If it is not possible to confirm that posture of JT2 = 90° with the teach pendant, align the scribe mark of the moving side and the end of scribe mark plate as shown in the figure below.

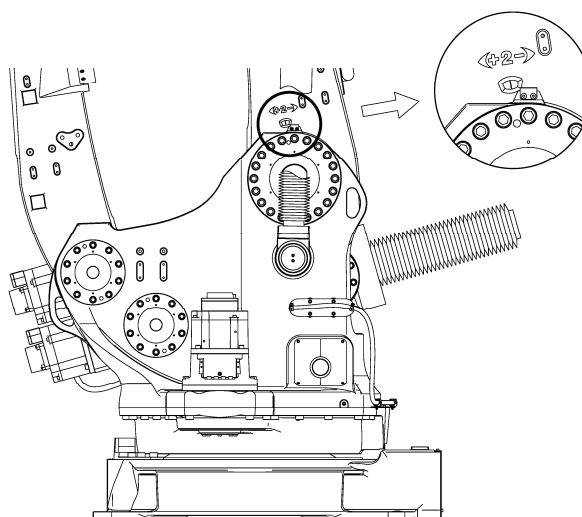

8 Mounting of Tools



WARNING

Prior to mounting tools on the robot, turn OFF the controller power switch and the external power switch. Display signs indicating clearly “Installation and connection in progress,” and lock out/tag out the external power switch to prevent personnel from accidentally turning ON the power.

8.1 Dimensions of Wrist End (Flange Surface)

In the robot arm end section, a flange is provided on which tools are mounted. Screw the mounting bolts (M16) into the tapped holes (depth: 34) on the circumference of $\phi 315$ on the flange, referring to the figure below. (Tightening torque: 235.2 N·m)
Moreover, position the tool by utilizing the pin holes (2- $\phi 12$ H7, Depth: 20).

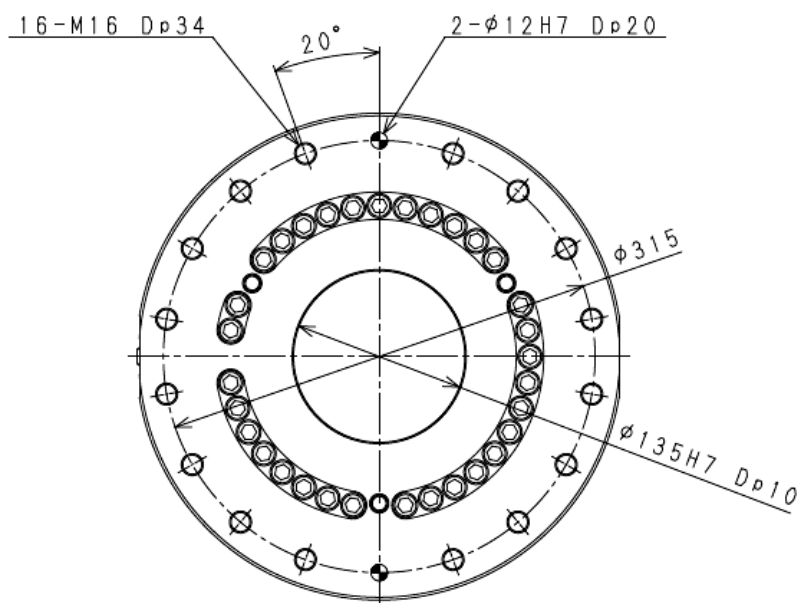

8.2 Specification of Mounting Bolt

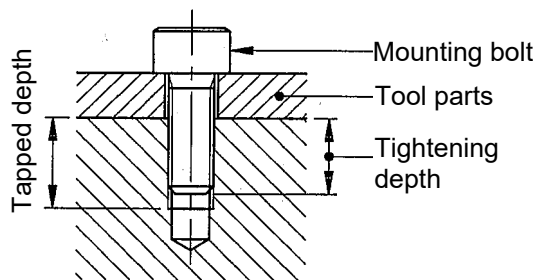

Select mounting bolts with proper length to secure the specified screwing depth according to the tapped depth of tool mounting flange. Use high tension mounting bolt (SCM435, 10.9 or more) and tighten them to the specified torque.



CAUTION

If the screwing depth has exceeded the specified value, the mounting bolt might bottom out, and the tool will not be fixed securely.

	Standard flange
Tapped hole	16-M16
ϕD	$\phi 315$
Pin hole	2- $\phi 12H7$ Depth 20
Tapped depth	34 mm
Tightening depth	24 to 33 mm
High tensile bolt	SCM435, 10.9 or more
Tightening torque	235.2 N·m

8.3 Load Capacity and JT3 Maximum Motion Range Limits

Load mass applicable to robot is specified for each model and includes the mass of tool, etc. Applicable load torque and moment of inertia around wrist axes (JT4, JT5, and JT6) are also specified. Strictly observe the following restrictions on them. Moreover, the motion range of JT3 on the plus side is limited depending on the load mass and the load torque.

CAUTION

Using the robot beyond its specified load may result in degradation of movement performance and shortening of machine service life. The load mass includes the tool mass such as hand, tool changer, spot welding gun, etc. If using the robot in excess of its load capacity, first contact Kawasaki without fail.

The load torque and the moment of inertia can be calculated by the expression below:

Calculation Expression

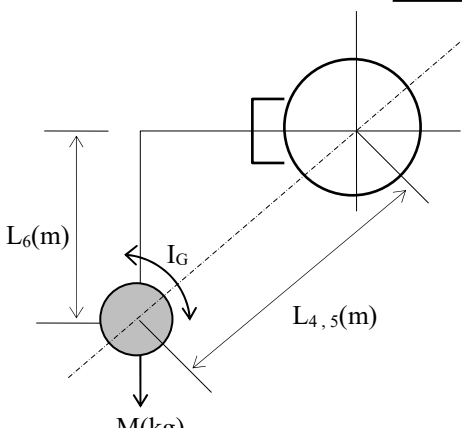

Load mass: $M \leq M_{max.}$ (kg)
(Including workpiece)

Load torque: $T = 9.8 \cdot M \cdot L$ (N·m)

Load moment of inertia: $I = M \cdot L^2 + I_G$ (kg·m²)

$M_{max.}$: Maximum load mass: See section 3.2.

$L_{4,5}$: Length from JT4(5) axis rotation center to load center of gravity

I_G : Moment of inertia around center of gravity (Unit: kg·m²)

L : Length from axis rotation center to load center of gravity (Unit: m) (See the figure.)

L_6 : Length from JT6 axis rotation center to load center of gravity

If calculation of load is made by dividing the load into multiple parts, such as tools and workpieces, use the total calculation values of each part as load torque and moment of inertia.

1. The load mass of the wrist section including tool mass should be the mass in the table below.

Model	Load mass
MG10HL	1000 kg
MG15HL	1500 kg

2. The load torque and the moment of inertia around each wrist axis (JT4, JT5, and JT6) should be within the following restriction.

⚠ CAUTION

Set the load data in Auxiliary function 0304 after mounting tools without fail. Operating the robot with wrong settings may cause vibrations in motion, degradation of movement performance and shortening of machine service life.

MG10HL

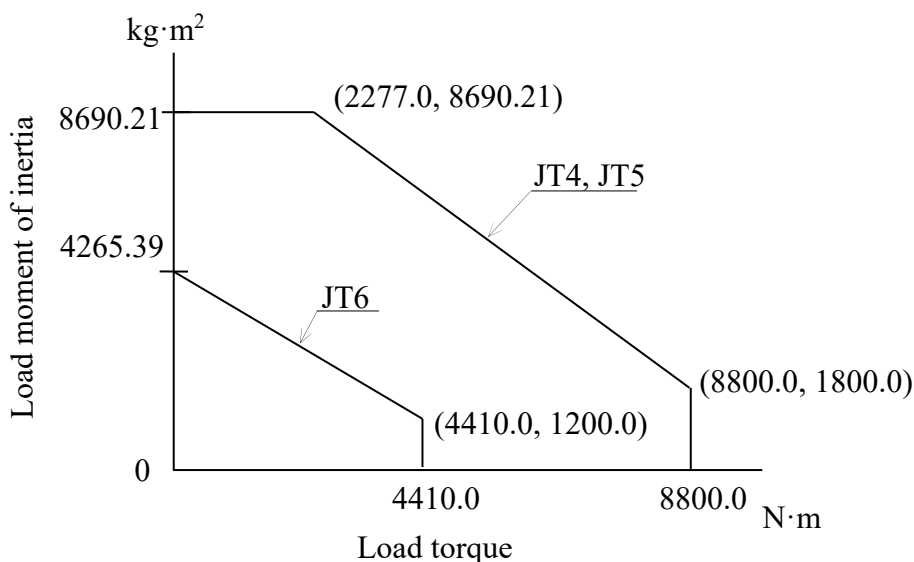

MG15HL

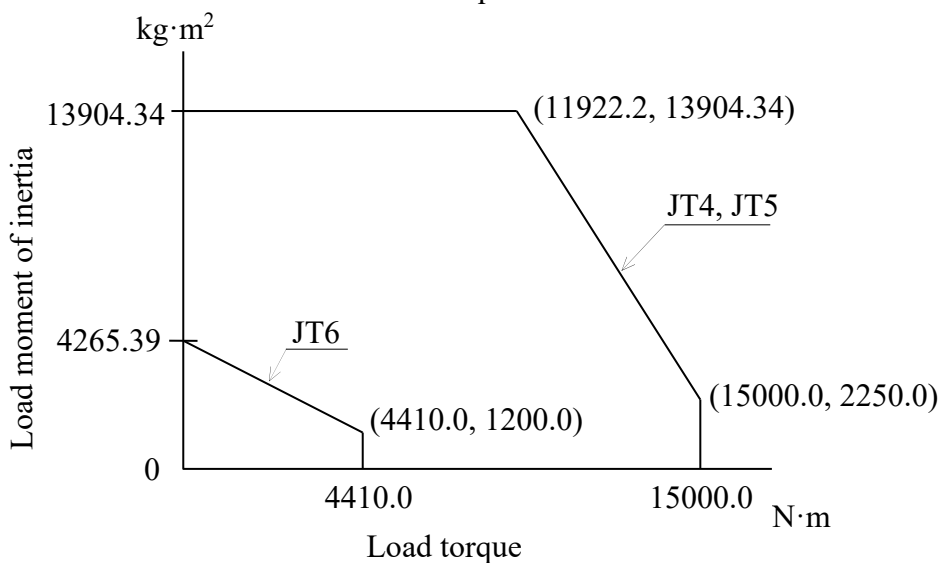

The motion range limits of JT3 (upper limit of motion range) can be calculated by the expression below (applicable to MG15HL only):

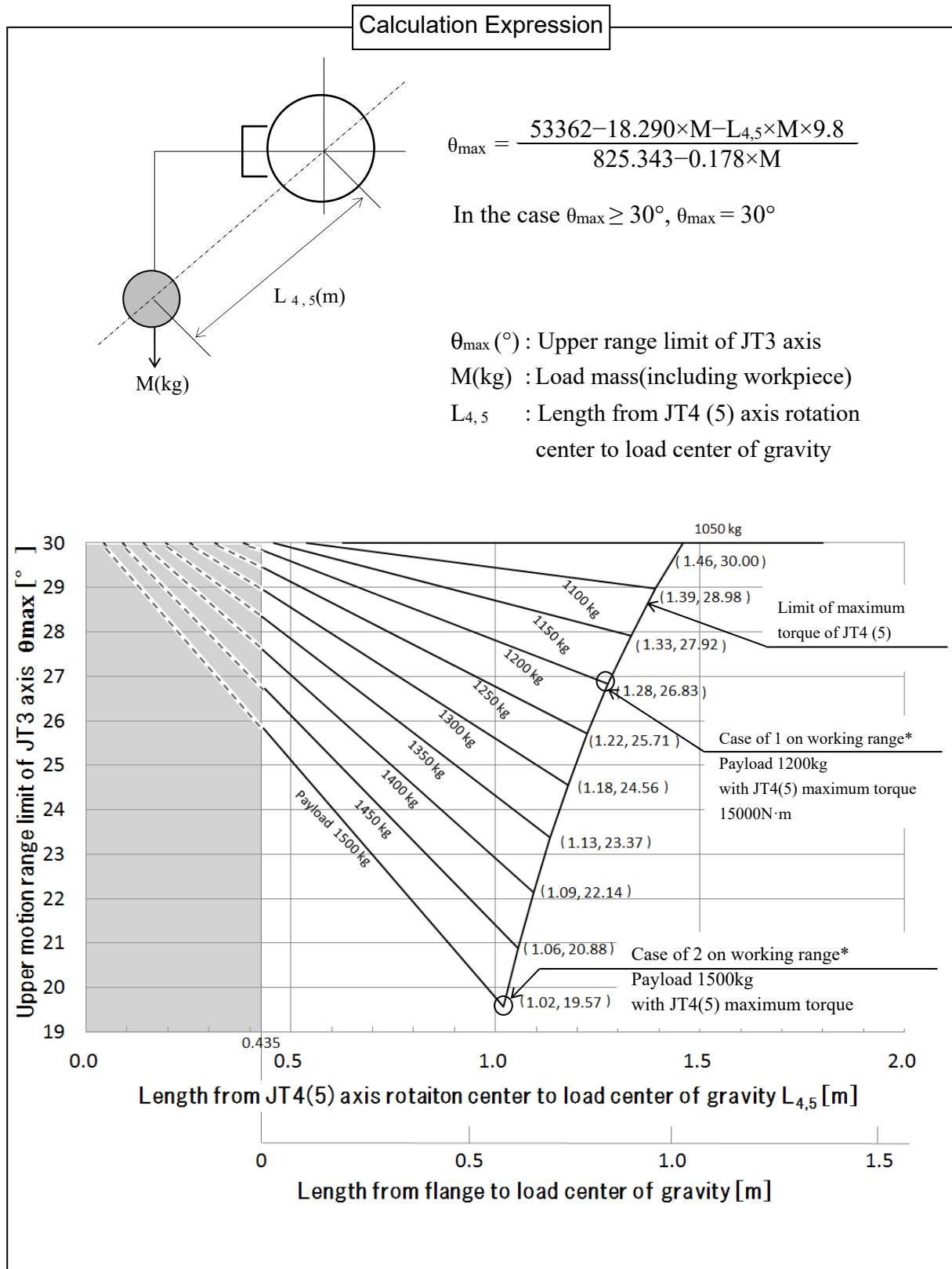

9 Mounting External Equipment

9.1 Service Tapped Hole Positions

Service tapped holes shown in the figure below are available to mount wiring brackets and external equipment on each part of MG series (Ver. B) robot arm.

⚠ CAUTION

Check the robot movement very carefully and confirm that mounted brackets and external equipment do not interfere with peripheral equipment and robot arm itself.

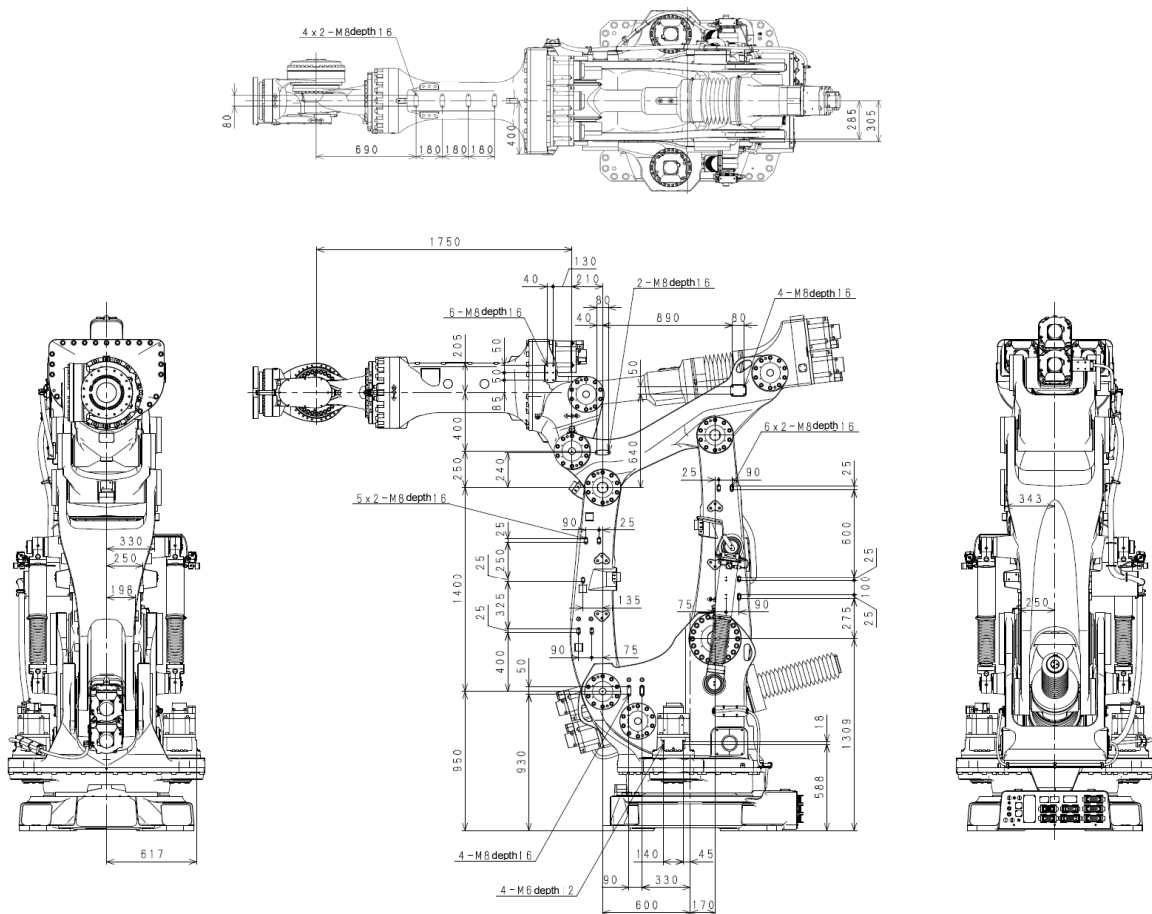

10 JT2 Stop/Storage Posture

! WARNING

A gas spring is used for JT2. The arm may fall depending on the JT2 posture when degassed. The JT2 angle in stop/storage of robot should be less than the range of the upper and lower limit angles shown in the figure below. The upper and lower limit angles change depending on the load.

MG10HL

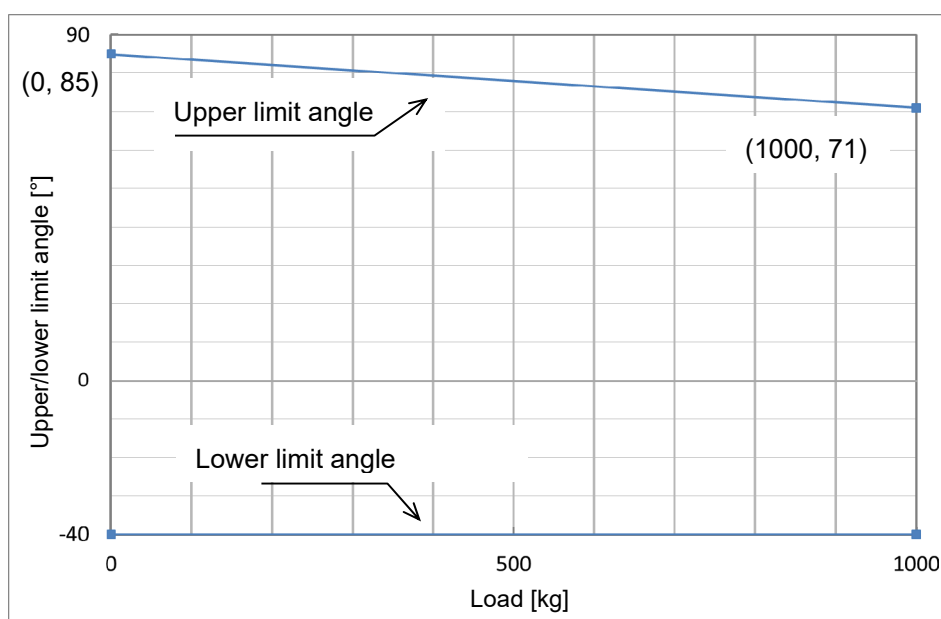

MG15HL

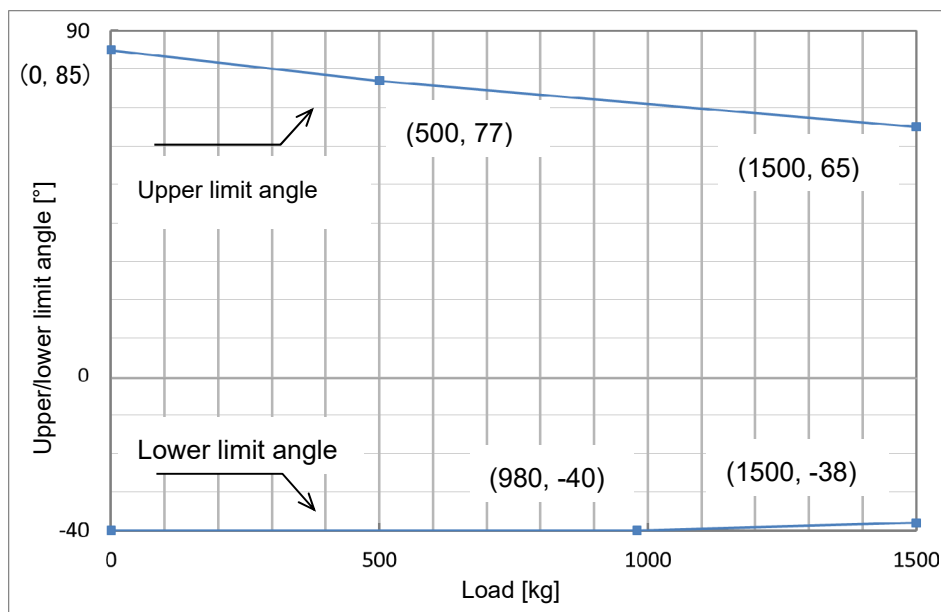



Kawasaki Robot MG Series (Ver.B)
Installation and Connection Manual

2017-04 : 1st Edition

2024-03 : 5th Edition

Publication : Kawasaki Heavy Industries, Ltd.

90202-1179DEE

Copyright © 2017 Kawasaki Heavy Industries, Ltd. All rights reserved.