

Kawasaki Heavy Industries, Ltd

Robot Business Division

Tokyo Head Office/Robot Division

1-14-5, Kaigan, Minato-ku, Tokyo 105-8315, Japan
Phone: +81-3-3435-2501 Fax: +81-3-3437-9880

Akashi Works/Robot Division

1-1, Kawasaki-cho, Akashi, Hyogo 673-8666, Japan
Phone: +81-78-921-2946 Fax: +81-78-923-6548

Nishi-Kobe Works/Robot Division

234, Matsumoto, Hasetani-cho, Nishi-ku, Kobe, Hyogo 651-2239, Japan
Phone: +81-78-915-8136 Fax: +81-78-915-8274

Kawasaki Robotics website

<https://kawasakirobotics.com/>



Kawasaki Robostage (showroom)

<https://kawasakirobotics.com/jp-sp/robostage/en/>



Global Network

Kawasaki Robotics (USA), Inc.

28140 Lakeview Drive, Wixom, MI 48393, U.S.A.
Phone: +1-248-446-4100 Fax: +1-248-446-4200

Kawasaki Robotics (UK) Ltd.

Unit 4 Easter Court, Europa Boulevard, Westbrook
Warrington Cheshire, WA5 7ZB, United Kingdom
Phone: +44-1925-71-3000 Fax: +44-1925-71-3001

Kawasaki Robotics GmbH

Im Taubental 32, 41468 Neuss, Germany
Phone: +49-2131-34260 Fax: +49-2131-3426-22

Kawasaki Robotics Korea, Ltd.

NO. 6-10, 14th floor, 1dong, 135, Gasan digital 2-ro,
Geumcheon-gu, Seoul, Republic of Korea
Phone: +82-32-821-6941 Fax: +82-32-821-6947

Kawasaki Robotics (Tianjin) Co., Ltd.

1-2/F, Building 6, No.19 Xinhuan Road, TEDA, China
Phone: +86-22-5983-1888 Fax: +86-22-5983-1889

Taiwan Kawasaki Robot Center

3F, No.31, Ln.216, Gongyuan Rd., Hsinchu City
30069, Taiwan(R.O.C)
Phone: +886-3-562-0518

Kawasaki Motors Enterprise (Thailand) Co., Ltd.

(Rayong Robot Center)
119/10 Moo 4 T.Pluaek Daeng, A.Pluaek Daeng, Rayong 21140
Thailand
Phone: +66-38-955-040-58 Fax: +66-38-955-145

Singapore Kawasaki Robot Center

100G Pasir Panjang Road #06-10
Singapore 118523
Phone: +65-6513-3145

Kawasaki Robotics India Pvt. Ltd.

1/5, Village-Khandsa, Khasra No. 1364,599/2/2/1,
Hero Honda Chowk,Gurgaon-122001, Haryana
Phone: +91-124-608-5500

Kawasaki Robot Palletizing Robots

Small-to-medium robots
up to 80kg payload

Large robots
up to 300kg payload

Extra large robots
up to 1,500kg payload

Dual-arm Collaborative robots

Explosion-proof painting robots

Sealing robots

Arc welding robots

Palletizing robots

Medical & pharmaceutical robots

Picking robots

Wafer transfer robots

Self-Propelled Robot



CAUTIONS TO BE TAKEN TO ENSURE SAFETY

- For those persons involved with the operation / service of your system, including Kawasaki Robot, they must strictly observe all safety regulations at all times. They should carefully read the Manuals and other related safety documents.
- Products described in this catalogue are general industrial robots. Therefore, if a customer wishes to use the Robot for special purposes, which might endanger operators or if the Robot has any problems, please contact us. We will be pleased to help you.
- Be careful as Photographs illustrated in this catalogue are frequently taken after removing safety fences and other safety devices stipulated in the safety regulations from the Robot operation system.



Palletizing Robots

Kawasaki offers a wide range of palletizing robots from 80 to 700 kg payload. The full product lineup delivers high throughput palletizing and solutions for labor shortage in the logistic industry and in-house factory logistics.

CP series

The CP series covers 110, 180, 300, 500 and 700 kg payload. These five models achieve a high productivity of palletizing in diverse industries.



CP110L

CP180L/300L

CP500L/700L

RD series

The RD series palletizing robot has the payload capacity of 80 kg. Thanks to its compact arm design, it can be installed in a confined space.



RD080N

CP/RD series

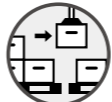
[Applications]  Palletizing

Features

- The full lineup covers diverse weights and sizes of workpieces.
- The industry-leading speed achieves an efficient palletizing system.
- The Cubic-S (an optional safety monitoring function) achieves safe operations of the system.

CP110L

Standard Specifications

Type	Articulated robot	
Degree of freedom (axes)	4	
Payload (kg)	110	
Max. reach (mm)	2,505	
Position repeatability*1 (mm)	±0.05	
Motion range (°)	Arm rotation (JT1)	±180
	Arm out-in (JT2)	+100 - -40
	Arm up-down (JT3)	+13 - -112
	Wrist swivel (JT4)	±360
Max. speed (°/s)	Arm rotation (JT1)	145
	Arm out-in (JT2)	140
	Arm up-down (JT3)	170
	Wrist swivel (JT4)	420
Allowable moment of inertia (kg·m ²)	Wrist swivel (JT4)	70
Mass (kg)	820	
Mounting	Floor	
Installation environment	Ambient temperature (°C)	0 - 45
	Relative humidity (%)	35 - 85 (No dew, nor frost allowed)
Controller/Power requirements	F03/12kVA	

*1: Conforms to ISO9283

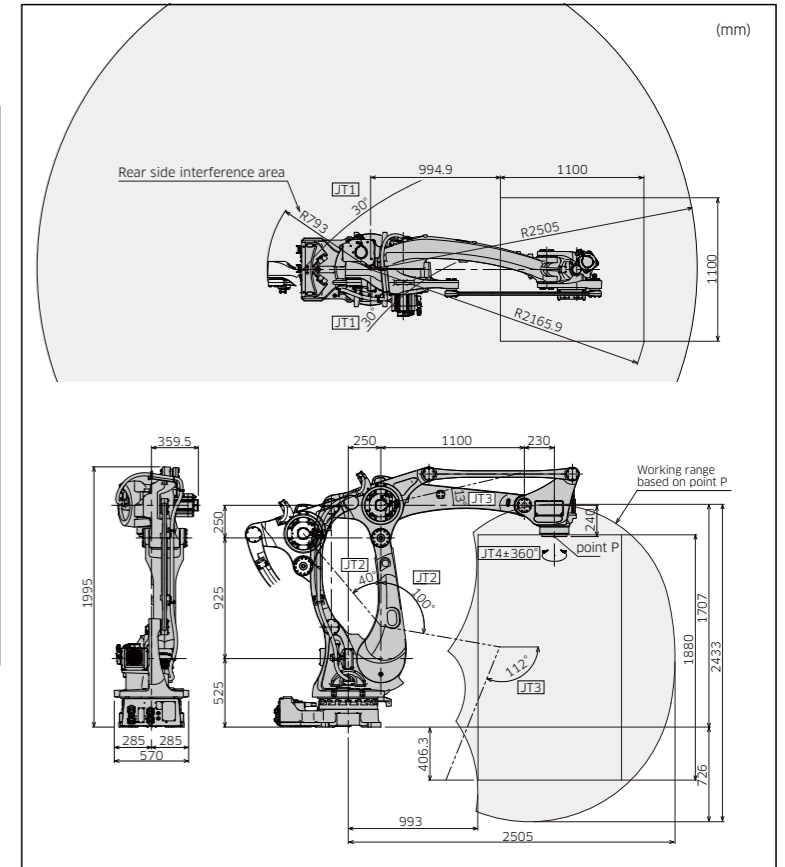

CP180L/300L

Standard Specifications

	CP180L	CP300L			
Type	Articulated robot				
Degree of freedom (axes)	4				
Max. reach (mm)	3,255				
Position repeatability*1 (mm)	±0.5				
Motion range (°)	Arm rotation (JT1)	±160			
	Arm out-in (JT2)	+95 - -46			
	Arm up-down (JT3)	+15 - -110			
	Wrist swivel (JT4)	±360			
Payload (kg)	130	180	250	300	
Max. speed*2 (°/s)	Arm rotation (JT1)	140	130	115	100
	Arm out-in (JT2)	125	120	100	90
	Arm up-down (JT3)	130	125	100	90
	Wrist swivel (JT4)	400	330	250	220
Allowable moment of inertia (kg·m ²)	Wrist swivel (JT4)	50	85	100	140
Mass (kg)	1,600				
Mounting	Floor				
Installation environment	Ambient temperature (°C)	0 - 45			
	Relative humidity (%)	35 - 85 (No dew, nor frost allowed)			
Controller/Power requirements	F03/12kVA				

*1: Conforms to ISO9283

*2: The maximum speed varies depending on the load setting.

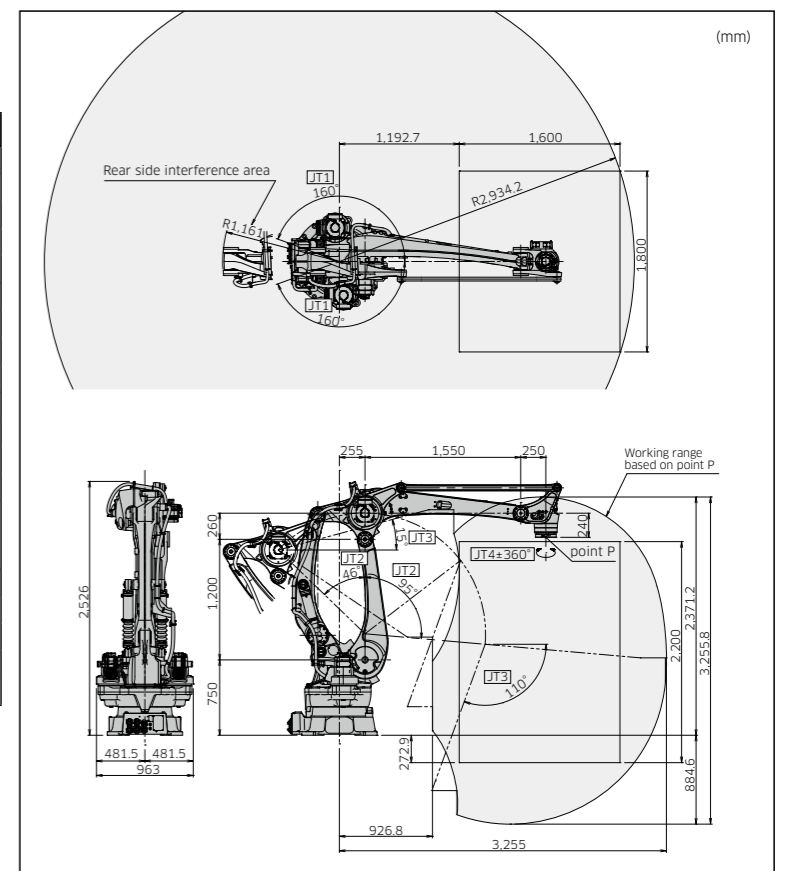

F03

CP500L/700L

Standard Specifications

		CP500L	CP700L
Type		Articulated robot	
Degree of freedom (axes)		4	
Payload (kg)		500	700
Max. reach (mm)		3,255	
Position repeatability*1 (mm)		±0.5	
Motion range (°)	Arm rotation (JT1)	±160	
	Arm out-in (JT2)	+95 - -46	
	Arm up-down (JT3)	+15 - -110	
	Wrist swivel (JT4)	±360	
Max. speed (°/s)	Arm rotation (JT1)	85	75
	Arm out-in (JT2)	80	65
	Arm up-down (JT3)	80	65
	Wrist swivel (JT4)	180	170
Allowable moment of inertia (kg·m ²)	Wrist swivel (JT4)	250	500
	Mass (kg)	1,650	
Mounting		Floor	
Installation environment	Ambient temperature (°C)	0 - 45	
	Relative humidity (%)	35 - 85 (No dew, nor frost allowed)	
Controller/Power requirements		F03/12kVA	

*1: Conforms to ISO9283

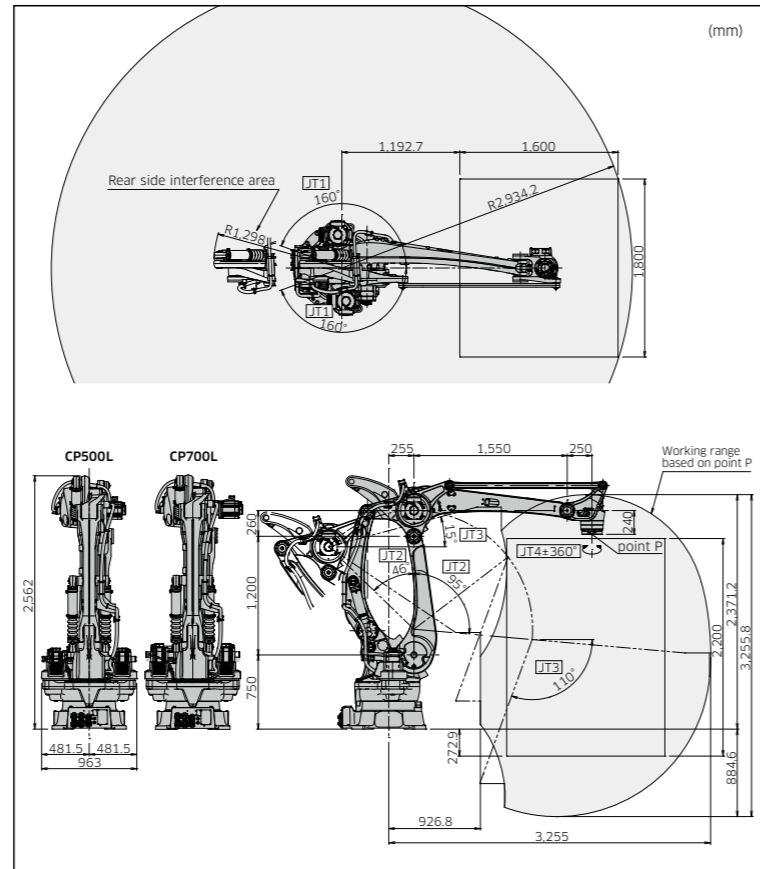

RD080N

Standard Specifications

		Articulated robot	
Degree of freedom (axes)		5	
Payload (kg)		80	
Max. reach (mm)		2,100	
Position repeatability*1 (mm)		±0.07	
Motion range (°)	Arm rotation (JT1)	±180	
	Arm out-in (JT2)	+140 - -105	
	Arm up-down (JT3)	+40 - -205	
	Wrist swivel (JT4)	±360	
	Wrist compensation (JT5)	±10° ²	
Max. speed (°/s)	Arm rotation (JT1)	180	
	Arm out-in (JT2)	180	
	Arm up-down (JT3)	175	
	Wrist swivel (JT4)	360	
Allowable moment of inertia (kg·m ²)	Wrist swivel (JT4)	13.7	
	Mass (kg)	540	
Mounting		Floor	
Installation environment	Ambient temperature (°C)	0 - 45	
	Relative humidity (%)	35 - 85 (No dew, nor frost allowed)	
Controller/Power requirements		F03/12kVA	

*1: Conforms to ISO9283

*2: Operating angle of the JT5 is ±10 degrees perpendicular to the ground.

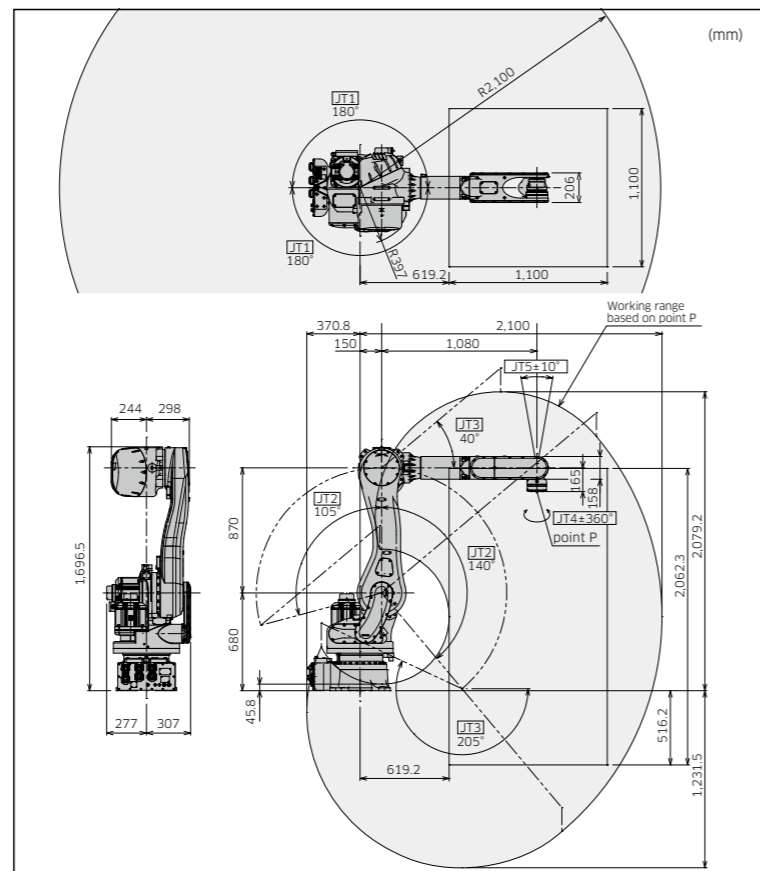

Features

- Dimensions and weight have been reduced from its previous E-controller.
- This universal controller has common specifications that can be used globally. (An optional transformer unit is necessary in the region where the power supply and safety standard differ.)



Standard Specifications

Dimensions (mm)		W420×D530×H278
Type		Enclosed type, indirect cooling system
Controlled (axes)		5
Memory capacity (MB)		16
I/O signals	External operation	Motor power off, Hold
	Input (Channels)	32
Cable length	Teach pendant (m)	5
	Robot-controller (m)	5
Mass (kg)		30
Power requirements		AC200V - AC220V ±10%, 50/60Hz, 3Φ AC200V - AC230V ±10%, 50/60Hz, 1Φ Max. 12kVA
Installation environment	Ambient temperature (°C)	0 - 45
	Relative humidity (%)	35 - 85 (No dew, nor frost allowed)
Teach pendant		Color LCD display with touch-panel, E-Stop switch, Teach lock switch, Enable switch
Operation panel		E-stop switch, teach/repeat switch

External view and dimensions

F03

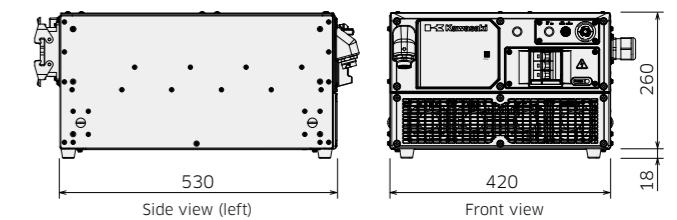

Transformer unit *Option

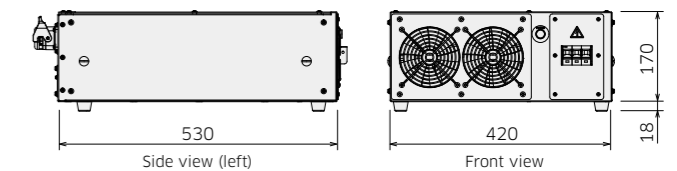

System configuration

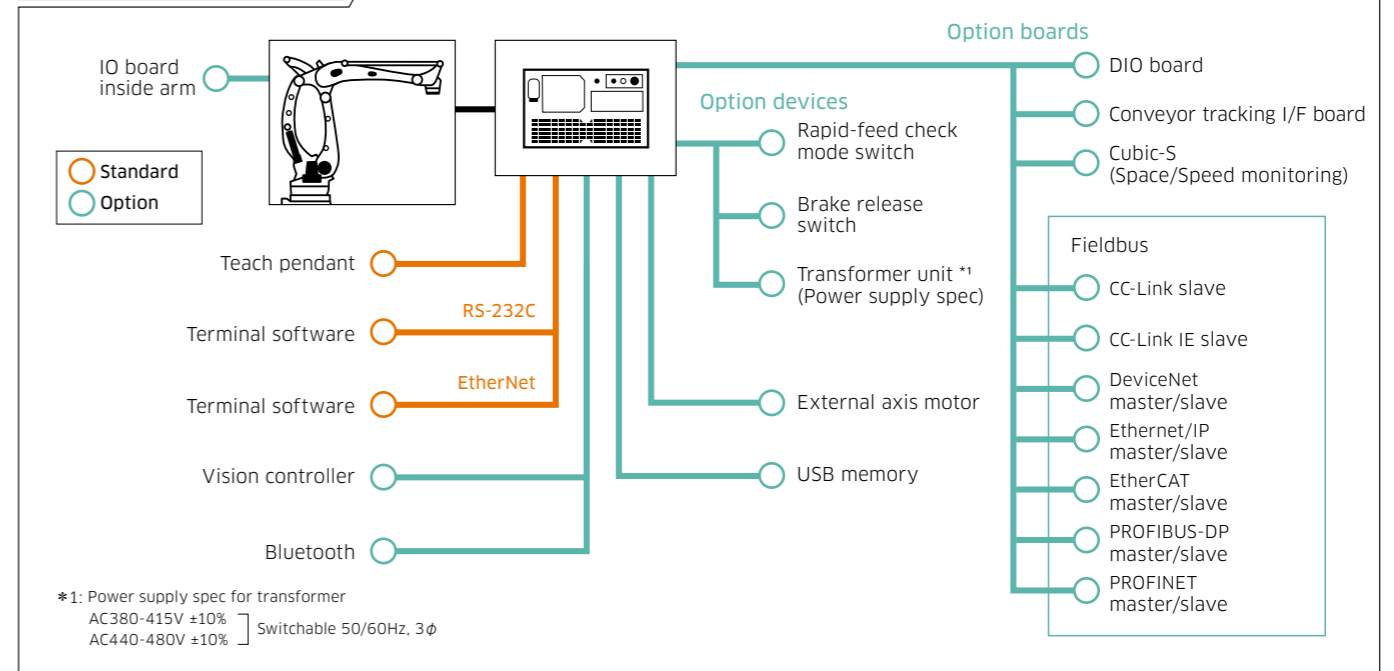

Palletizing Robot Performance

Kawasaki's palletizing robots typically achieve a processing capacity of approximately 1,200 units per hour when handling one box or one bag at a time (varies depending on robot model). Under certain conditions, they can process up to 2,200 units per hour. When handling multiple boxes or bags simultaneously (e.g., palletizing an entire layer of cardboard boxes), the processing capacity increases further, enabling more efficient operations.

CP series | Long reach, capable of handling up to 6 pallets and 2,200 units per hour

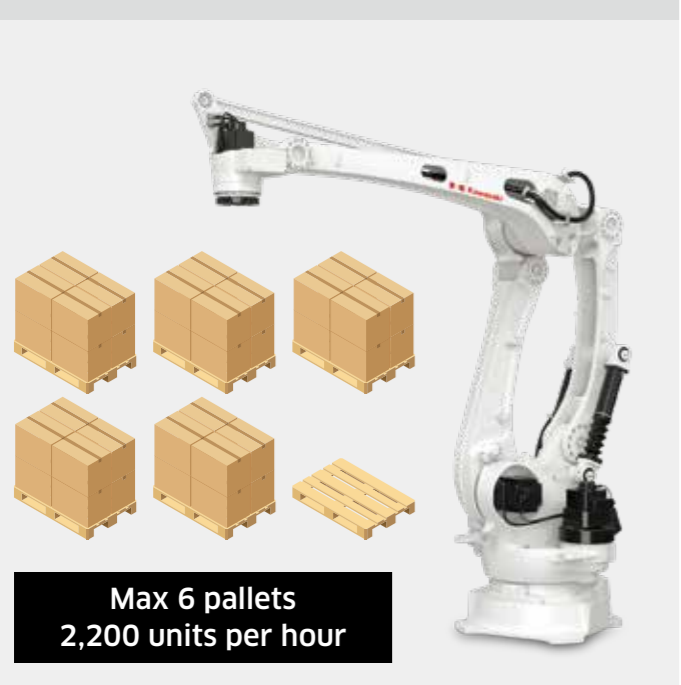

RD series | Compact footprint, suitable for 2-3 pallets and 800 units per hour



※The above processing capacities are reference values and may vary depending on the robot model, shape and weight of the items, transport conditions, and surrounding equipment configuration.
 ※The maximum processing capacity listed is based on optimal conditions and should be reviewed individually for actual implementation.
 ※For pallet heights exceeding the standard 2.2 meters, CP series robots are recommended.

Applicable Products for Palletizing

Kawasaki's palletizing robots support automation of palletizing tasks for a wide variety of product shapes and sizes, including cardboard boxes, bags, and drums. They enable simultaneous handling of multiple items and mixed palletizing of different product types, contributing to flexible and efficient logistics operations.

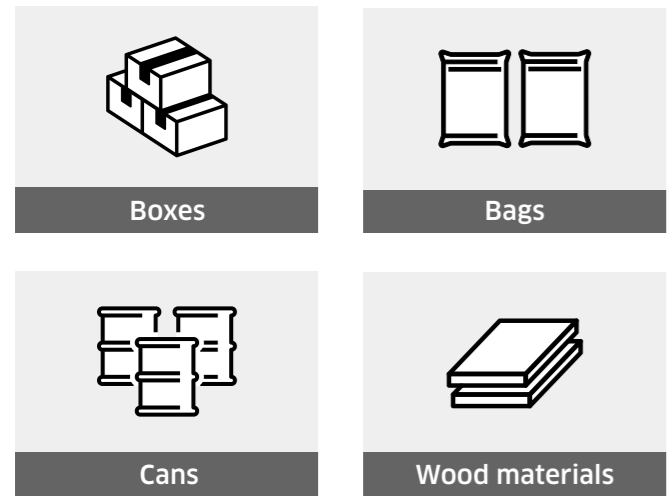

※In addition to the above, the robots can handle many other shapes and sizes of products.

Palletizing two flour bags simultaneously



Palletizing mixed product types



neoROSET is a PC-based programming support tool developed by Kawasaki that enables intuitive robot programming and accurate simulation. By performing offline verification in advance, it helps reduce risks associated with robot system implementation and shortens setup time significantly.



Key Features of neoROSET

- Dramatically reduces teaching time
- Backward compatibility with legacy software K-ROSET
- Supports import of various 3D CAD formats
- Simple and intuitive operation

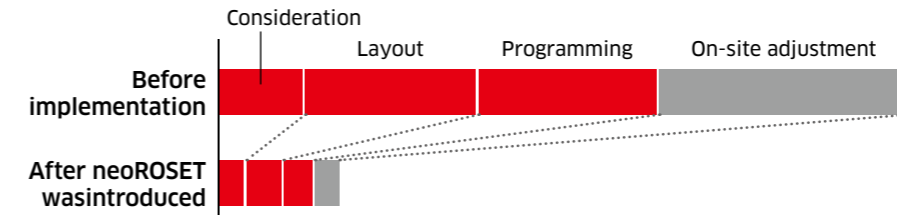

By using neoROSET, the time required for conventional offline teaching and adjustment can be reduced to a fraction or even up to one-tenth.

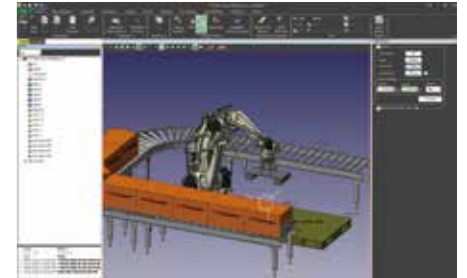

Its intuitive graphical user interface allows users to visually create robot programs, even without specialized programming knowledge.

Palletizing-Specific Optional Functions

Previously, defining palletizing patterns and handling product variations required complex layout design and programming, often leading to errors such as collisions or misplacements. Training and operation at the site were also challenging. Kawasaki's neoROSET Palletizing Function simplifies this process, allowing anyone to easily configure palletizing settings. It supports smooth and efficient implementation of palletizing robots.

※This function requires an additional optional license in addition to the standard neoROSET license.

6-Step Setup for Accurate and Efficient Palletizing

1. Select robot and material-hand

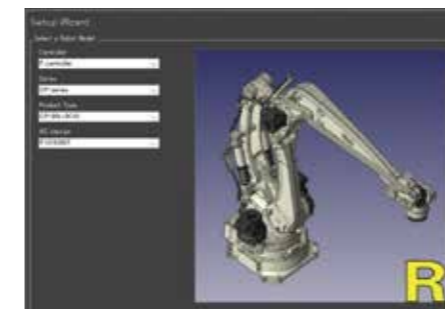

Automatically applies settings for Kawasaki R, B, Z, and M series robots, considering model-specific motion characteristics and constraints.

2. Choose layout pattern

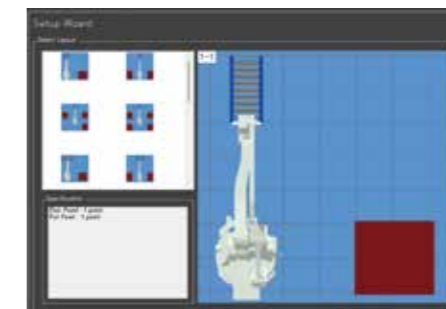

Multiple layout templates are available. Simply selecting one applies the optimal configuration, significantly reducing design time.

3. Set workpiece and pallet dimensions

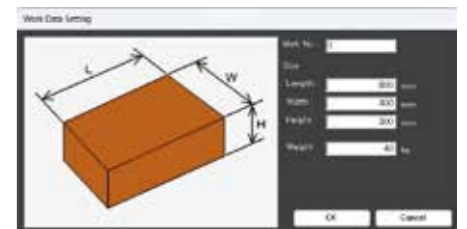

Supports various shapes such as boxes and bags. Entering dimensions automatically defines stacking conditions (height, spacing, stability, etc.).

4. Automatically generate palletizing positions

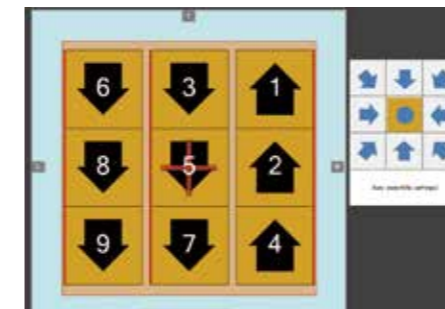

Choose from over 100 built-in patterns. Positions are generated automatically, enabling high-precision setup even without specialized knowledge.

5. Load positions into the robot



Automatically generated position data is transferred to the robot, preventing manual input errors and enabling accurate cycle time analysis.

6. Execute the program



Use the virtual teach pendant (TP) for intuitive operation. Product types and pallet numbers can be set and simulated. Standard signal assignments for interlocks between upper-level controllers and the robot are also available, facilitating on-site deployment.