



# Standard Specifications

## RS007L-B

1st ed. 10-Apr-20  
2nd ed. 13-Oct-20  
3rd ed. 11-Sep-24

Kawasaki Heavy Industries, Ltd.  
Robot Business Division

Specification number : 90151-0314DEC

Materials and specifications are subject to change without notice.

## Robot specifications

1. Model	RS007L-B																									
2. Type	Articulated robot																									
3. Degree of freedom	6 axes																									
4. Max. payload	7 kg																									
5. Max. reach	930 mm																									
6. Position repeatability	±0.03 mm (wrist flange surface) conforms to ISO 9283																									
7. Axis specification	<table border="1"> <thead> <tr> <th>Operating axis</th> <th>Motion range</th> <th>Max. speed</th> </tr> </thead> <tbody> <tr> <td>Arm rotation (JT1)</td> <td>±180°</td> <td>370°/s</td> </tr> <tr> <td>Arm out-in (JT2)</td> <td>±135°</td> <td>310°/s</td> </tr> <tr> <td>Arm up-down (JT3)</td> <td>±157°</td> <td>410°/s</td> </tr> <tr> <td>Wrist swivel (JT4)</td> <td>±200°</td> <td>550°/s</td> </tr> <tr> <td>Wrist bend (JT5)</td> <td>±125°</td> <td>550°/s</td> </tr> <tr> <td>Wrist twist (JT6)</td> <td>±360°</td> <td>1,000°/s</td> </tr> </tbody> </table>		Operating axis	Motion range	Max. speed	Arm rotation (JT1)	±180°	370°/s	Arm out-in (JT2)	±135°	310°/s	Arm up-down (JT3)	±157°	410°/s	Wrist swivel (JT4)	±200°	550°/s	Wrist bend (JT5)	±125°	550°/s	Wrist twist (JT6)	±360°	1,000°/s			
Operating axis	Motion range	Max. speed																								
Arm rotation (JT1)	±180°	370°/s																								
Arm out-in (JT2)	±135°	310°/s																								
Arm up-down (JT3)	±157°	410°/s																								
Wrist swivel (JT4)	±200°	550°/s																								
Wrist bend (JT5)	±125°	550°/s																								
Wrist twist (JT6)	±360°	1,000°/s																								
8. Load capacity of wrist	<table border="1"> <thead> <tr> <th></th> <th>Max. torque</th> <th>Moment of inertia*<sup>1</sup></th> </tr> </thead> <tbody> <tr> <td>JT4</td> <td>17.0 N·m</td> <td>0.50 kg·m<sup>2</sup></td> </tr> <tr> <td>JT5</td> <td>17.0 N·m</td> <td>0.50 kg·m<sup>2</sup></td> </tr> <tr> <td>JT6</td> <td>10.0 N·m</td> <td>0.20 kg·m<sup>2</sup></td> </tr> </tbody> </table> <p>Note *<sup>1</sup> Each value in this table shows allowable moment of inertia of JT4/JT5/JT6 when max. allowed torque is applied to each axis. If more detailed data is required for your application, please contact Kawasaki.</p>			Max. torque	Moment of inertia* <sup>1</sup>	JT4	17.0 N·m	0.50 kg·m <sup>2</sup>	JT5	17.0 N·m	0.50 kg·m <sup>2</sup>	JT6	10.0 N·m	0.20 kg·m <sup>2</sup>												
	Max. torque	Moment of inertia* <sup>1</sup>																								
JT4	17.0 N·m	0.50 kg·m <sup>2</sup>																								
JT5	17.0 N·m	0.50 kg·m <sup>2</sup>																								
JT6	10.0 N·m	0.20 kg·m <sup>2</sup>																								
9. Mass	36 kg (without options)																									
10. Mounting	Floor or Ceiling mounting																									
11. Installation Environment	Ambient Temperature : 0 - 45 °C Relative Humidity : 35 - 85 % (with no dew condensation)																									
12. Color	Munsell 10GY9/1 equivalent																									
13. Degree of protection	Wrist: IP67 equivalent, Arm: IP65 equivalent																									
14. Cleanliness	Class 6 equivalent Not a guaranteed value																									
15. Built-in utilities	Pneumatic piping (φ6 × 1 lines )																									
16. Options	<table border="1"> <tbody> <tr> <td>Mounting</td> <td>Wall mounting</td> </tr> <tr> <td>Degree of protection</td> <td>Arm : IP67 equivalent</td> </tr> <tr> <td rowspan="5">Option harness *<sup>2</sup></td> <td>Sensor harness (8 circuits)</td> </tr> <tr> <td>LAN harness (CAT5e, straight)</td> </tr> <tr> <td>External axis harness through wrist (motor/signal)</td> </tr> <tr> <td>External axis harness through base (motor/signal)</td> </tr> <tr> <td>Type D0 (I/O through harness)</td> </tr> <tr> <td>Solenoid valve</td> <td>Double solenoid / Single solenoid valves (3 units max.)</td> </tr> <tr> <td>Air cleaning</td> <td>Filter, Regulator, Mist separator</td> </tr> <tr> <td>Mechanical stopper</td> <td>Adjustable stopper JT1</td> </tr> <tr> <td>Adapter plate</td> <td>RS003/RS005 changing plate</td> </tr> <tr> <td>Installation stand</td> <td>300 mm, 600 mm height</td> </tr> <tr> <td>Base plate</td> <td>400 mm × 400 mm</td> </tr> <tr> <td>Servo on lamp</td> <td>Comply with UL (Lamp color: yellow)</td> </tr> </tbody> </table>		Mounting	Wall mounting	Degree of protection	Arm : IP67 equivalent	Option harness * <sup>2</sup>	Sensor harness (8 circuits)	LAN harness (CAT5e, straight)	External axis harness through wrist (motor/signal)	External axis harness through base (motor/signal)	Type D0 (I/O through harness)	Solenoid valve	Double solenoid / Single solenoid valves (3 units max.)	Air cleaning	Filter, Regulator, Mist separator	Mechanical stopper	Adjustable stopper JT1	Adapter plate	RS003/RS005 changing plate	Installation stand	300 mm, 600 mm height	Base plate	400 mm × 400 mm	Servo on lamp	Comply with UL (Lamp color: yellow)
Mounting	Wall mounting																									
Degree of protection	Arm : IP67 equivalent																									
Option harness * <sup>2</sup>	Sensor harness (8 circuits)																									
	LAN harness (CAT5e, straight)																									
	External axis harness through wrist (motor/signal)																									
	External axis harness through base (motor/signal)																									
	Type D0 (I/O through harness)																									
Solenoid valve	Double solenoid / Single solenoid valves (3 units max.)																									
Air cleaning	Filter, Regulator, Mist separator																									
Mechanical stopper	Adjustable stopper JT1																									
Adapter plate	RS003/RS005 changing plate																									
Installation stand	300 mm, 600 mm height																									
Base plate	400 mm × 400 mm																									
Servo on lamp	Comply with UL (Lamp color: yellow)																									

\*2: Not all option harness can be selected. Consult Kawasaki.

Consult Kawasaki about maintenance parts and spare parts.

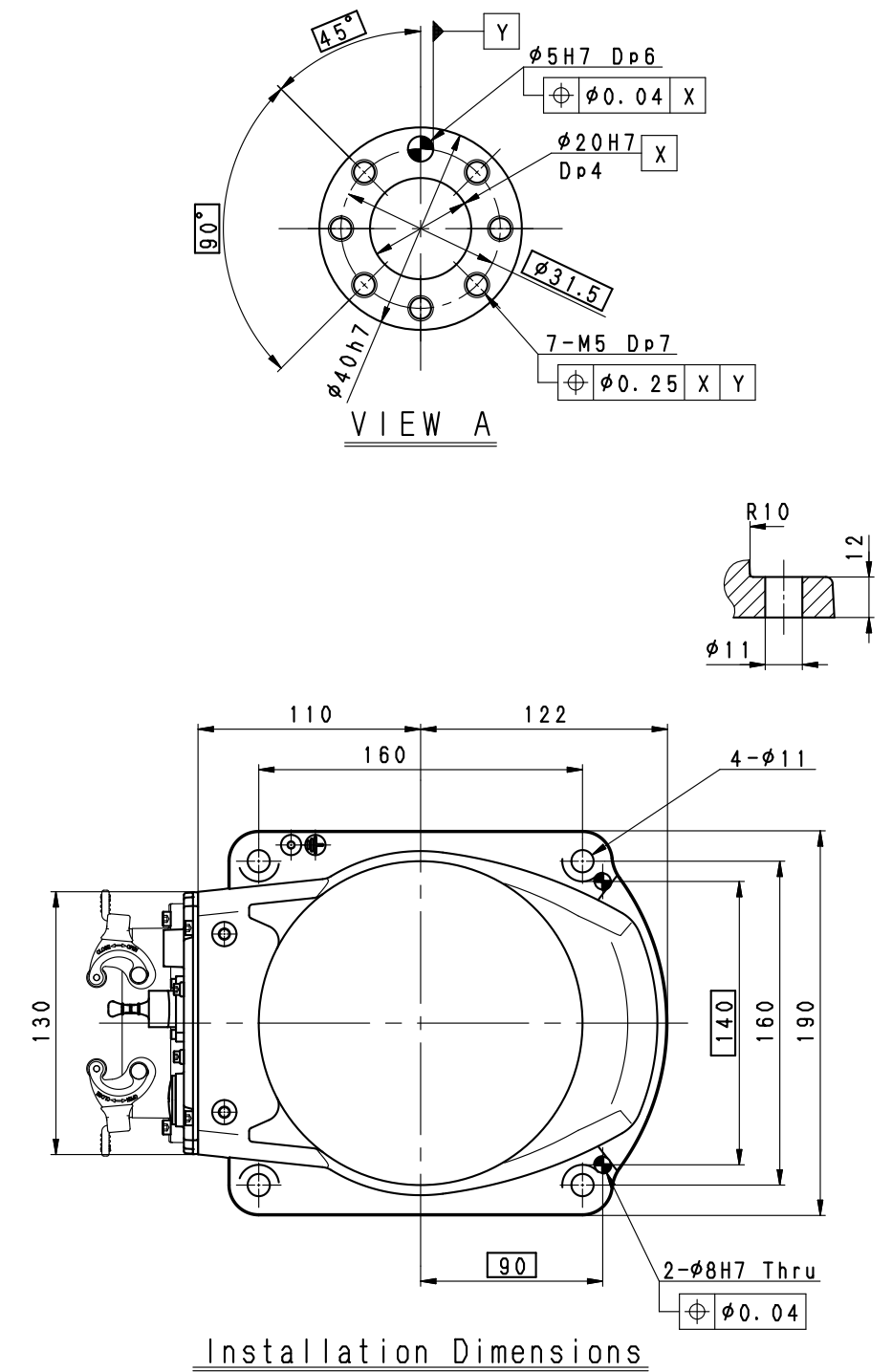
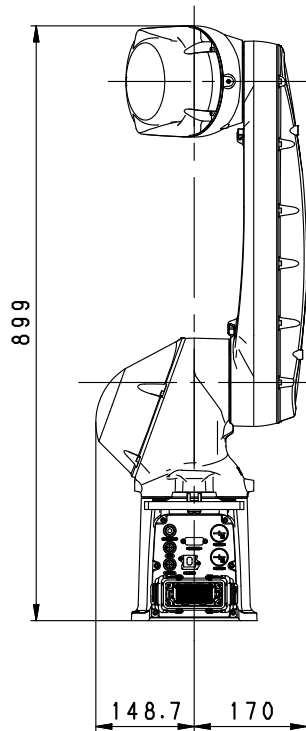
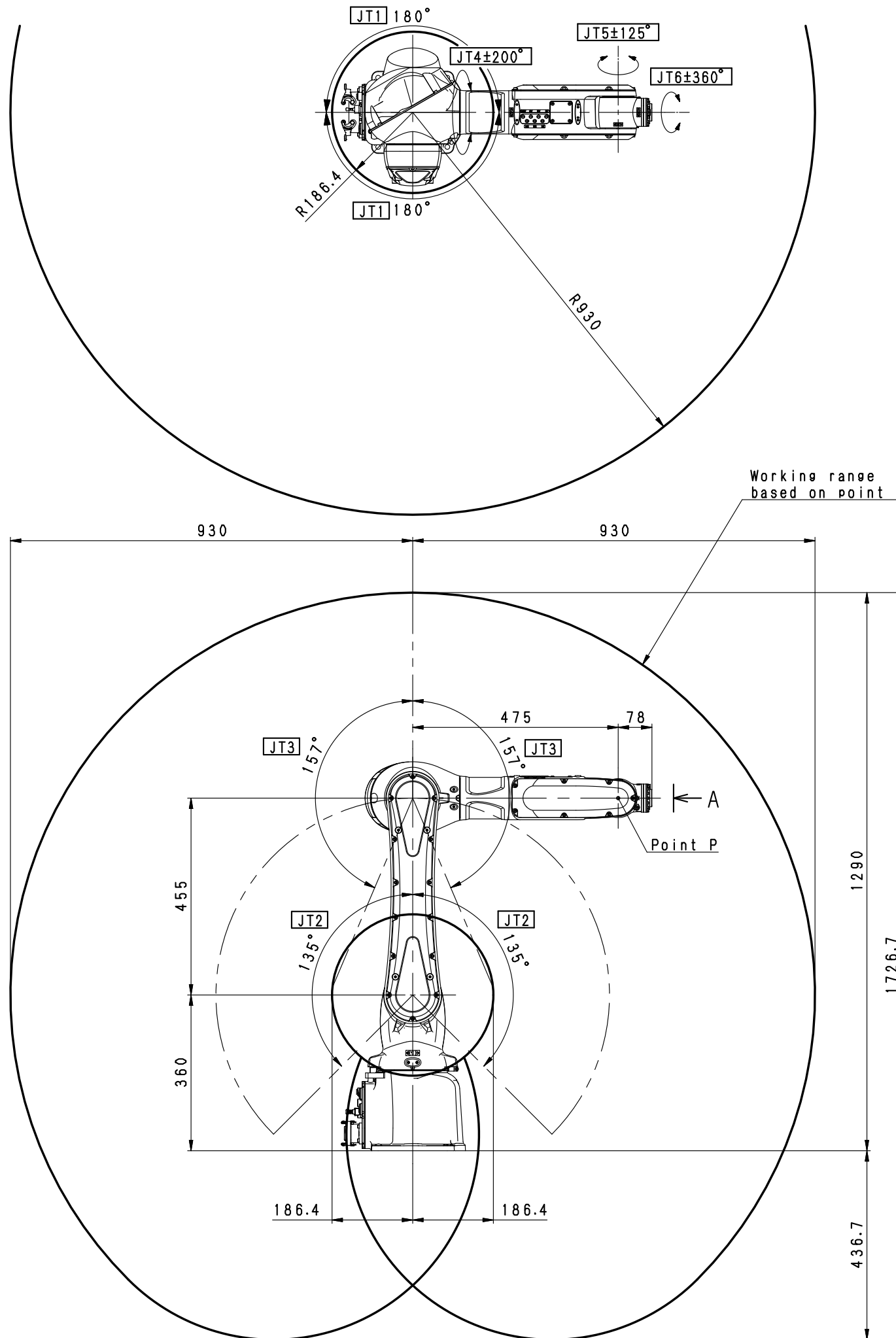

RS007L-B  
WORKING RANGE