



Standard Specifications

RS010L-A

1st ed. 18-Feb-15
2nd ed. 25-May-18
3rd ed. 12-Oct-20
4th ed. 11-Sep-24

Kawasaki Heavy Industries, Ltd.
Robot Business Division

Specification number : 90151-0047DED

Materials and specifications are subject to change without notice.

Robot specifications

1. Model	RS010L-A																						
2. Type	Articulated robot																						
3. Degree of freedom	6 axes																						
4. Max. payload	10 kg																						
5. Max. reach	1,925 mm																						
6. Position repeatability	±0.05 mm (wrist flange surface) conforms to ISO 9283																						
7. Axis specification	<table border="1"> <thead> <tr> <th>Operating axis</th> <th>Motion range</th> <th>Max. speed</th> </tr> </thead> <tbody> <tr> <td>Arm rotation (JT1)</td> <td>±180°</td> <td>190°/s</td> </tr> <tr> <td>Arm out-in (JT2)</td> <td>+155° - -105°</td> <td>205°/s</td> </tr> <tr> <td>Arm up-down (JT3)</td> <td>+150° - -163°</td> <td>210°/s</td> </tr> <tr> <td>Wrist swivel (JT4)</td> <td>±270°</td> <td>400°/s</td> </tr> <tr> <td>Wrist bend (JT5)</td> <td>±145°</td> <td>360°/s</td> </tr> <tr> <td>Wrist twist (JT6)</td> <td>±360°</td> <td>610°/s</td> </tr> </tbody> </table>		Operating axis	Motion range	Max. speed	Arm rotation (JT1)	±180°	190°/s	Arm out-in (JT2)	+155° - -105°	205°/s	Arm up-down (JT3)	+150° - -163°	210°/s	Wrist swivel (JT4)	±270°	400°/s	Wrist bend (JT5)	±145°	360°/s	Wrist twist (JT6)	±360°	610°/s
Operating axis	Motion range	Max. speed																					
Arm rotation (JT1)	±180°	190°/s																					
Arm out-in (JT2)	+155° - -105°	205°/s																					
Arm up-down (JT3)	+150° - -163°	210°/s																					
Wrist swivel (JT4)	±270°	400°/s																					
Wrist bend (JT5)	±145°	360°/s																					
Wrist twist (JT6)	±360°	610°/s																					
8. Load capacity of wrist	<table border="1"> <thead> <tr> <th></th> <th>Max. torque</th> <th>Moment of inertia*</th> </tr> </thead> <tbody> <tr> <td>JT4</td> <td>22 N·m</td> <td>0.7 kg·m²</td> </tr> <tr> <td>JT5</td> <td>22 N·m</td> <td>0.7 kg·m²</td> </tr> <tr> <td>JT6</td> <td>10 N·m</td> <td>0.2 kg·m²</td> </tr> </tbody> </table> <p>Note * Each value in this table shows allowable moment of inertia of JT4/JT5/JT6 when max. allowed torque is applied to each axis. If more detailed data is required for your application, please contact Kawasaki.</p>			Max. torque	Moment of inertia*	JT4	22 N·m	0.7 kg·m ²	JT5	22 N·m	0.7 kg·m ²	JT6	10 N·m	0.2 kg·m ²									
	Max. torque	Moment of inertia*																					
JT4	22 N·m	0.7 kg·m ²																					
JT5	22 N·m	0.7 kg·m ²																					
JT6	10 N·m	0.2 kg·m ²																					
9. Mass	230 kg (without options)																						
10. Mounting	Floor or Ceiling mounting																						
11. Installation Environment	Ambient Temperature: 0 - 45 °C																						
	Relative Humidity: 35 - 85 % (with no dew condensation)																						
12. Color	Munsell 10GY9/1 equivalent																						
13. Degree of protection	Wrist: IP67 equivalent, Arm: IP65 equivalent																						
14. Cleanliness	Class 6 equivalent Not a guaranteed value																						
15. Built-in utilities	Pneumatic piping (φ8 × 2 lines)																						
16. Options	Mounting	Wall mounting																					
	Degree of protection	Arm: IP67 equivalent																					
	Sensor harness	12 circuits, wired inside robot arm																					
	Solenoid valve	Double solenoid / Single solenoid valves (4 units max.)																					
	Air cleaning	Filter, Regulator, Mist separator																					
	Mechanical stopper	Adjustable stoppers JT1/JT2/JT3																					
	Color																						
	Installation stand	300 mm, 600 mm height																					
	Base plate	750 mm × 750 mm																					

Consult Kawasaki about maintenance parts and spare parts.

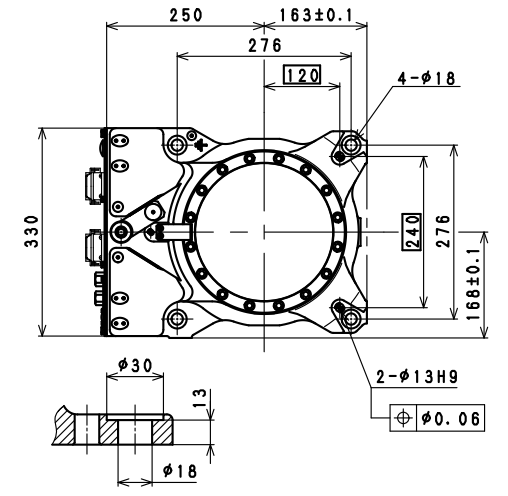
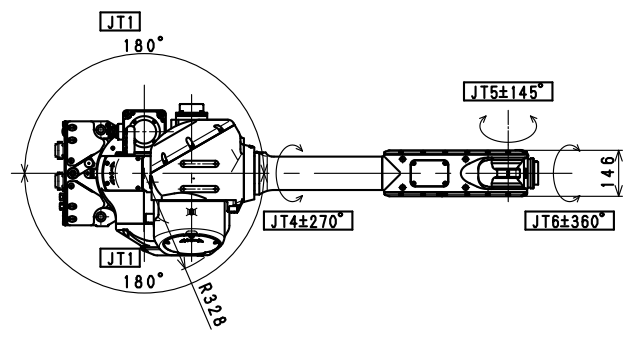

Installation Dimensions

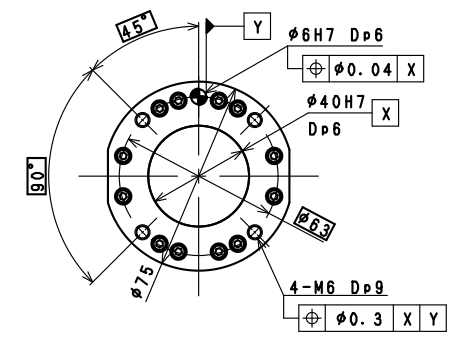
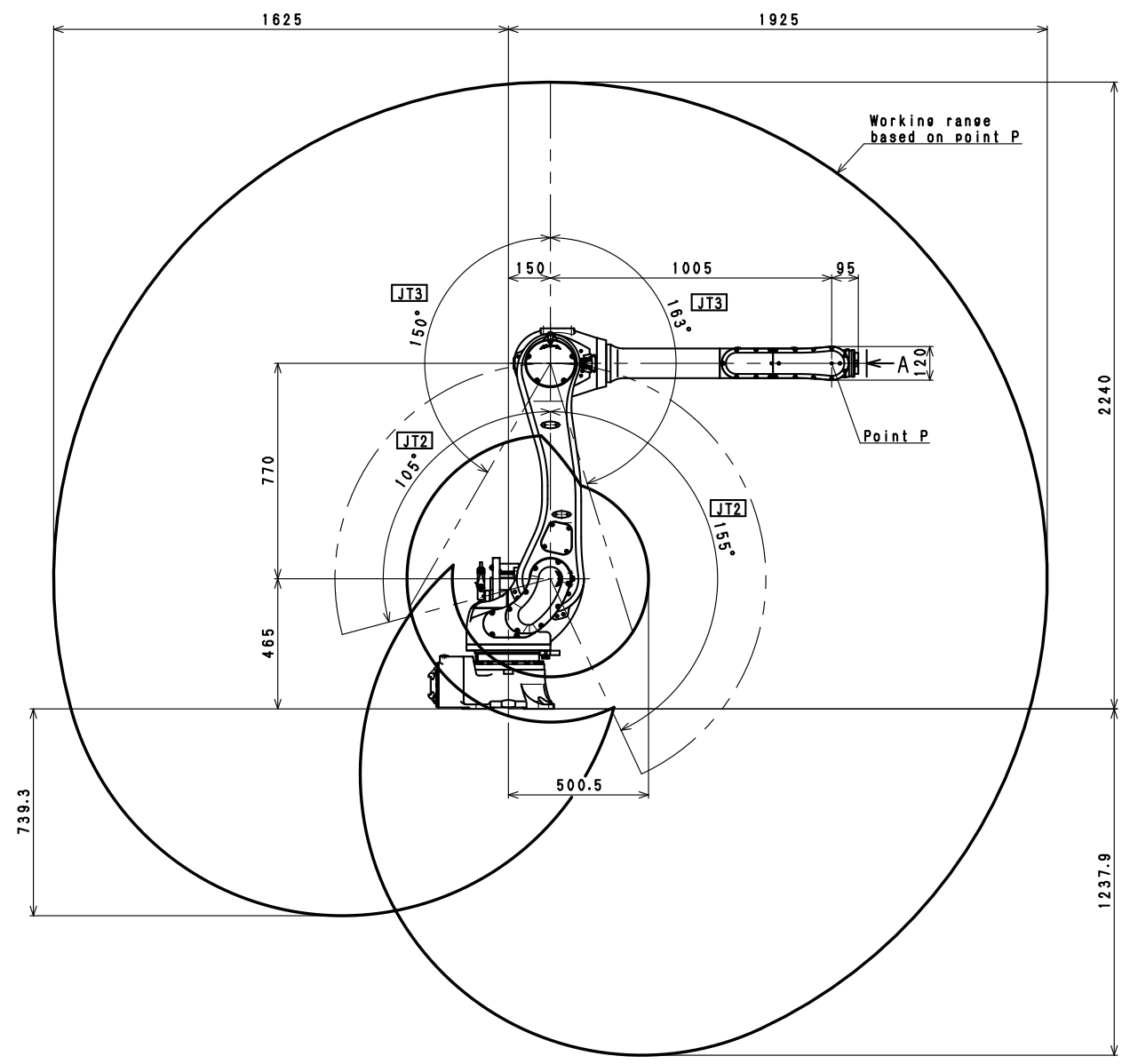
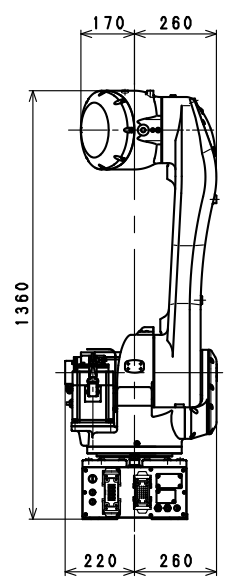

VIEW A

RS010L
WORKING RANGE