

Kawasaki Heavy Industries, Ltd

Robot Business Division

Tokyo Head Office/Robot Division

1-14-5, Kaigan, Minato-ku, Tokyo 105-8315, Japan
Phone: +81-3-3435-2501 Fax: +81-3-3437-9880

Akashi Works/Robot Division

1-1, Kawasaki-cho, Akashi, Hyogo 673-8666, Japan
Phone: +81-78-921-2946 Fax: +81-78-923-6548

Nishi-Kobe Works/Robot Division

234, Matsumoto, Hasetani-cho, Nishi-ku, Kobe, Hyogo 651-2239, Japan
Phone: +81-78-915-8136 Fax: +81-78-915-8274

Kawasaki Robotics website

<https://kawasakirobotics.com/>



Kawasaki Robostage (showroom)

<https://kawasakirobotics.com/jp-sp/robostage/en/>



Kawasaki Robot

Small-to-Medium Robots

up to 80kg payload

Small-to-medium robots
up to 80kg payload

Large robots
up to 300kg payload

Extra large robots
up to 1,500kg payload

Dual-arm Collaborative robots

Explosion-proof painting robots

Sealing robots

Arc welding robots

Palletizing robots

Medical & pharmaceutical robots

Picking robots

Wafer transfer robots

Global Network

Kawasaki Robotics (USA), Inc.

28140 Lakeview Drive, Wixom, MI 48393, U.S.A.
Phone: +1-248-446-4100 Fax: +1-248-446-4200

Kawasaki Robotics (UK) Ltd.

Unit 4 Easter Court, Europa Boulevard, Westbrook
Warrington Cheshire, WA5 7ZB, United Kingdom
Phone: +44-1925-71-3000 Fax: +44-1925-71-3001

Kawasaki Robotics GmbH

Im Taubental 32, 41468 Neuss, Germany
Phone: +49-2131-34260 Fax: +49-2131-3426-22

Kawasaki Robotics Korea, Ltd.

43, Namdong-daero 215beon-gil, Namdong-gu, Incheon,
21633, Korea
Phone: +82-32-821-6941 Fax: +82-32-821-6947

Kawasaki Robotics (Tianjin) Co., Ltd.

1-2/F, Building 6, No.19 Xinhuan Road, TEDA, China
Phone: +86-22-5983-1888 Fax: +86-22-5983-1889

Taiwan Kawasaki Robot Center

3F, No.31, Ln.216, Gongyuan Rd., Hsinchu City
30069, Taiwan(R.O.C)
Phone: +886-3-562-0518

Kawasaki Motors Enterprise (Thailand) Co., Ltd.

(Rayong Robot Center)
119/10 Moo 4 T.Pluaek Daeng, A.Pluaek Daeng, Rayong 21140
Thailand
Phone: +66-38-955-040-58 Fax: +66-38-955-145

Singapore Kawasaki Robot Center

100G Pasir Panjang Road #06-10
Singapore 118523
Phone: +65-6513-3145

Kawasaki Robotics India Pvt. Ltd.

Plot No. 136, Sector-37, Pace City 1,
Gurgaon, 122101 Haryana, India
Phone: +91-124-437-1845



CAUTIONS TO BE TAKEN TO ENSURE SAFETY

- For those persons involved with the operation / service of your system, including Kawasaki Robot, they must strictly observe all safety regulations at all times. They should carefully read the Manuals and other related safety documents.
- Products described in this catalogue are general industrial robots. Therefore, if a customer wishes to use the Robot for special purposes, which might endanger operators or if the Robot has any problems, please contact us. We will be pleased to help you.
- Be careful as Photographs illustrated in this catalogue are frequently taken after removing safety fences and other safety devices stipulated in the safety regulations from the Robot operation system.

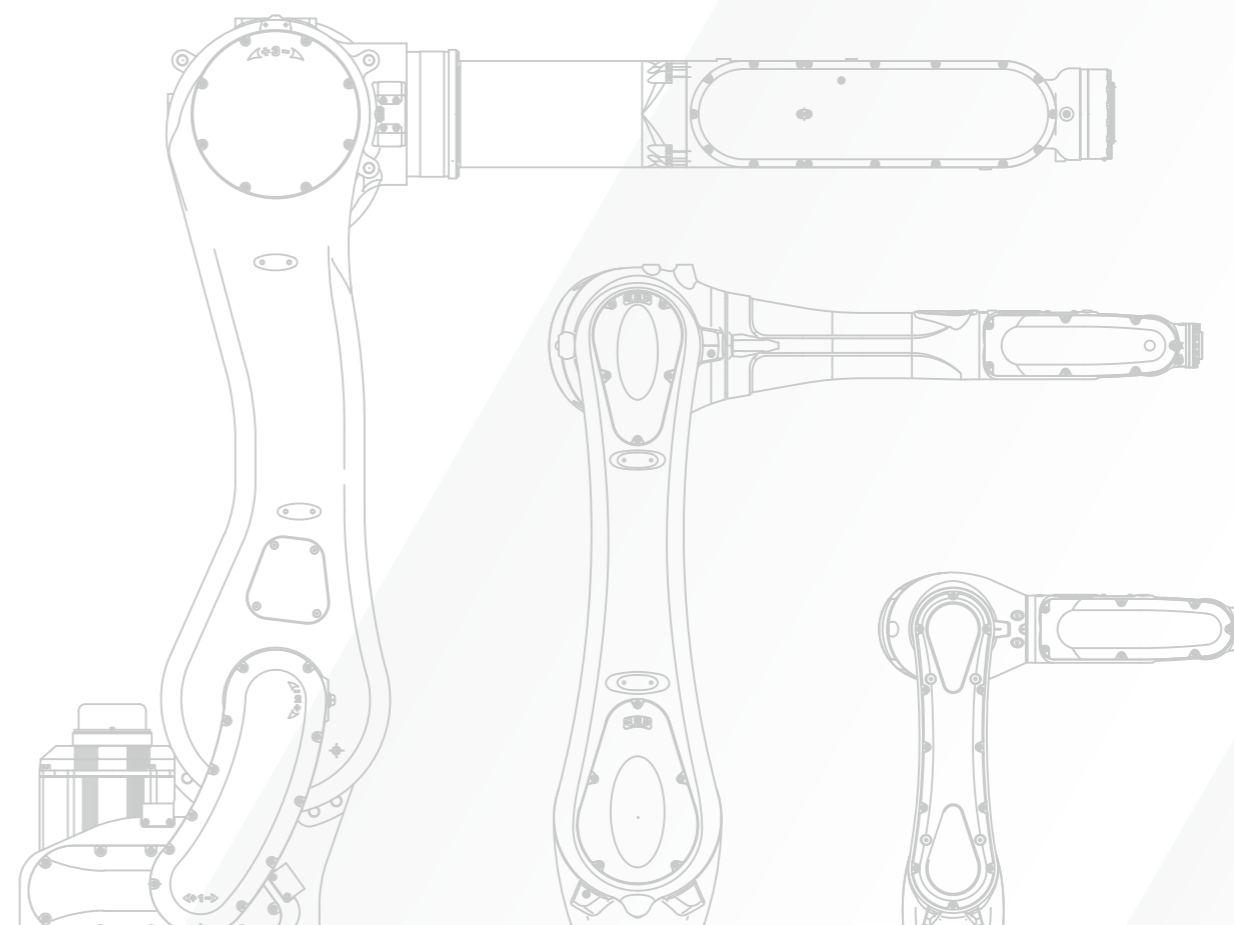

Small-to-medium, general-purpose robots

Kawasaki R series robots are setting the benchmark for all small to medium duty industrial robots. The compact design along with industry leading speed, reach, and work range makes the R series robots ideal for a wide range of applications throughout diverse industries.

RS series



RS003N

RS005N

RS005L



RS006L

RS007N

RS007L



RS010L

RS013N



RS015X

RS025N

RS030N/RS050N/RS080N

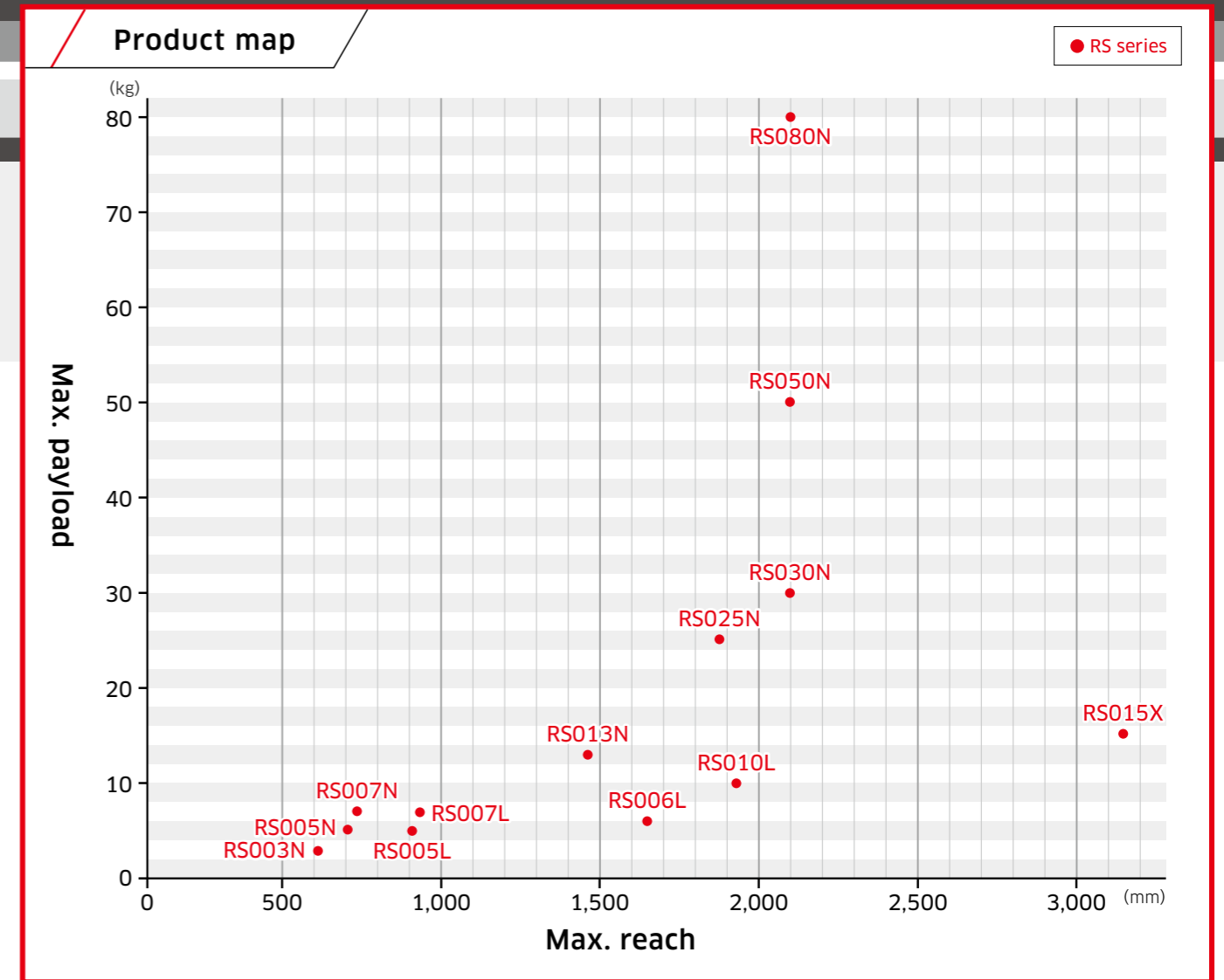

RS series

[Applications]

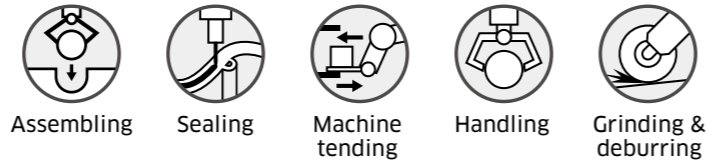

Assembling

Sealing

Machine tending

Handling

Grinding & deburring

RS003N

Standard Specifications

Type	Articulated robot	
Degree of freedom (axes)	6	
Payload (kg)	3	
Max. reach (mm)	620	
Position repeatability*1 (mm)	±0.02	
Motion range (°)	Arm rotation (JT1)	±160
	Arm out-in (JT2)	+150 - -60
	Arm up-down (JT3)	+120 - -150
	Wrist swivel (JT4)	±360
	Wrist bend (JT5)	±135
	Wrist twist (JT6)	±360
Max. speed (°/s)	Arm rotation (JT1)	360
	Arm out-in (JT2)	250
	Arm up-down (JT3)	225
	Wrist swivel (JT4)	540
	Wrist bend (JT5)	225
	Wrist twist (JT6)	540
Allowable moment (N·m)	Wrist swivel (JT4)	5.8
	Wrist bend (JT5)	5.8
	Wrist twist (JT6)	2.9
Allowable moment of inertia (kg·m²)	Wrist swivel (JT4)	0.12
	Wrist bend (JT5)	0.12
	Wrist twist (JT6)	0.03
Mass (kg)	20	
Mounting	Floor, Ceiling	
Installation environment	Ambient temperature (°C)	0 - 45
	Relative humidity (%)	35 - 85 (No dew, nor frost allowed)
Degee of protection	IP54 or equivalent	
Controller/Power requirements	F60/2.0kVA	

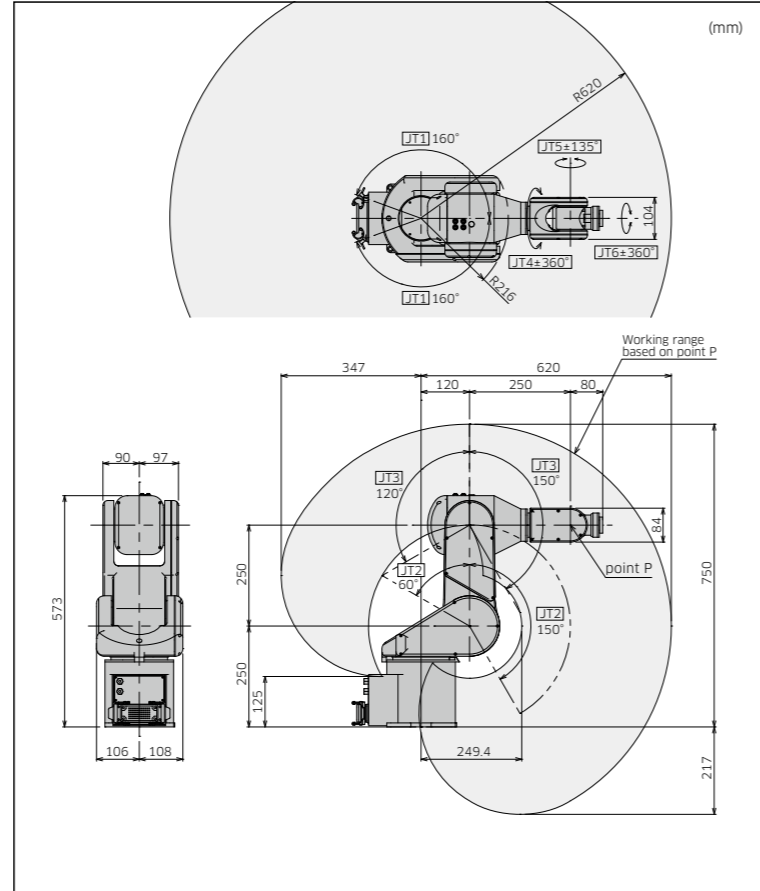

*1: Conforms to ISO9283

Features

- Full lineup for diverse applications
- Industry leading speed
- Compact, yet wide work range

RS005L

Standard Specifications

Type	Articulated robot	
Degree of freedom (axes)	6	
Payload (kg)	5	
Max. reach (mm)	903	
Position repeatability*1 (mm)	±0.03	
Motion range (°)	Arm rotation (JT1)	±180
	Arm out-in (JT2)	+135 - -80
	Arm up-down (JT3)	+118 - -172
	Wrist swivel (JT4)	±360
	Wrist bend (JT5)	±145
	Wrist twist (JT6)	±360
Max. speed (°/s)	Arm rotation (JT1)	300
	Arm out-in (JT2)	300
	Arm up-down (JT3)	300
	Wrist swivel (JT4)	460
	Wrist bend (JT5)	460
	Wrist twist (JT6)	740
Allowable moment (N·m)	Wrist swivel (JT4)	12.3
	Wrist bend (JT5)	12.3
	Wrist twist (JT6)	7
Allowable moment of inertia (kg·m²)	Wrist swivel (JT4)	0.4
	Wrist bend (JT5)	0.4
	Wrist twist (JT6)	0.12
Mass (kg)	37	
Mounting	Floor, Ceiling	
Installation environment	Ambient temperature (°C)	0 - 45
	Relative humidity (%)	35 - 85 (No dew, nor frost allowed)
Degee of protection	Wrist: IP67 or equivalent Base axes: IP65 or equivalent	
Controller/Power requirements	F60/2.0kVA	

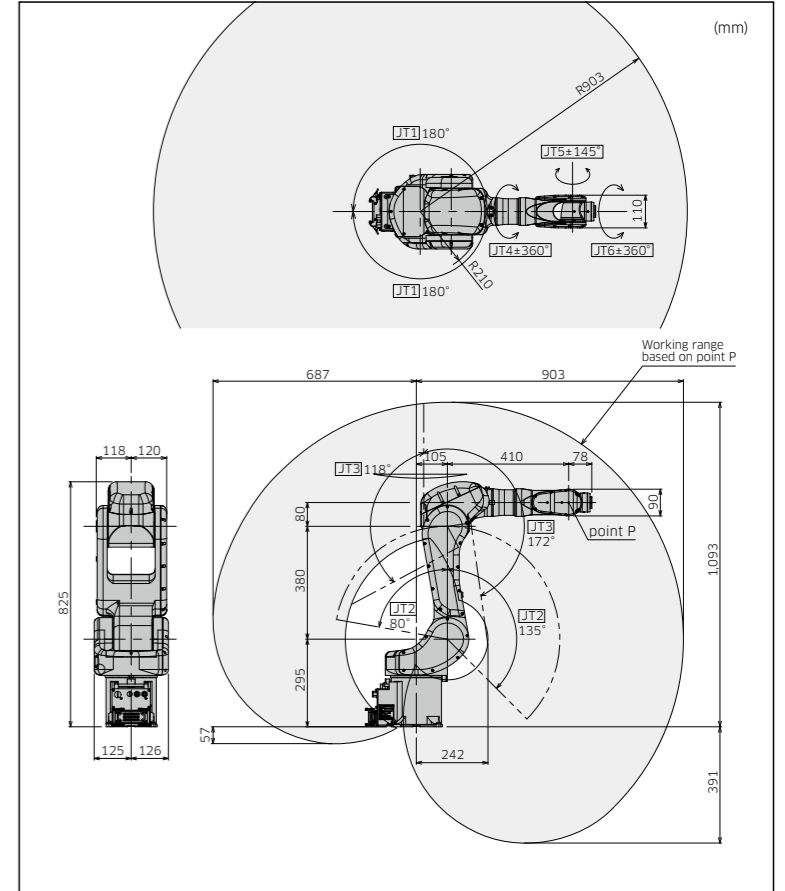

*1: Conforms to ISO9283

RS005N

Standard Specifications

Type	Articulated robot	
Degree of freedom (axes)	6	
Payload (kg)	5	
Max. reach (mm)	705	
Position repeatability*1 (mm)	±0.02	
Motion range (°)	Arm rotation (JT1)	±180
	Arm out-in (JT2)	+135 - -80
	Arm up-down (JT3)	+118 - -172
	Wrist swivel (JT4)	±360
	Wrist bend (JT5)	±145
	Wrist twist (JT6)	±360
Max. speed (°/s)	Arm rotation (JT1)	360
	Arm out-in (JT2)	360
	Arm up-down (JT3)	410
	Wrist swivel (JT4)	460
	Wrist bend (JT5)	460
	Wrist twist (JT6)	740
Allowable moment (N·m)	Wrist swivel (JT4)	12.3
	Wrist bend (JT5)	12.3
	Wrist twist (JT6)	7
Allowable moment of inertia (kg·m²)	Wrist swivel (JT4)	0.4
	Wrist bend (JT5)	0.4
	Wrist twist (JT6)	0.12
Mass (kg)	34	
Mounting	Floor, Ceiling	
Installation environment	Ambient temperature (°C)	0 - 45
	Relative humidity (%)	35 - 85 (No dew, nor frost allowed)
Degee of protection	Wrist: IP67 or equivalent Base axes: IP65 or equivalent	
Controller/Power requirements	F60/2.0kVA	

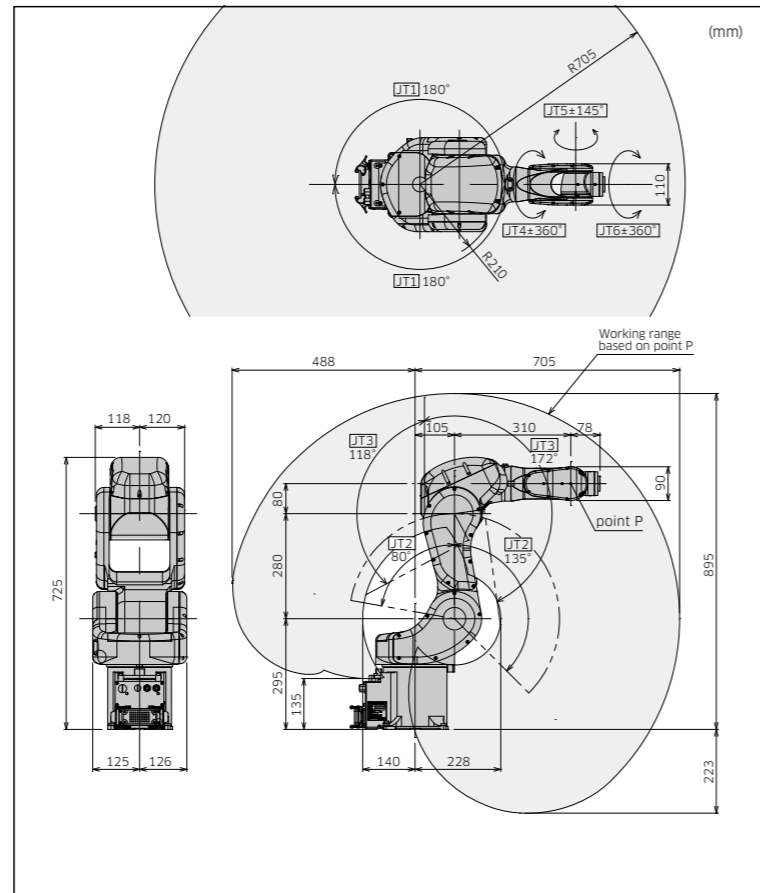

*1: Conforms to ISO9283

RS006L

Standard Specifications

Type	Articulated robot	
Degree of freedom (axes)	6	
Payload (kg)	6	
Max. reach (mm)	1,650	
Position repeatability*1 (mm)	±0.03	
Motion range (°)	Arm rotation (JT1)	±180
	Arm out-in (JT2)	+145 - -105
	Arm up-down (JT3)	+150 - -163
	Wrist swivel (JT4)	±270
	Wrist bend (JT5)	±145
	Wrist twist (JT6)	±360
Max. speed (°/s)	Arm rotation (JT1)	250
	Arm out-in (JT2)	250
	Arm up-down (JT3)	215
	Wrist swivel (JT4)	365
	Wrist bend (JT5)	380
	Wrist twist (JT6)	700
Allowable moment (N·m)	Wrist swivel (JT4)	13
	Wrist bend (JT5)	13
	Wrist twist (JT6)	7.5
Allowable moment of inertia (kg·m²)	Wrist swivel (JT4)	0.45
	Wrist bend (JT5)	0.45
	Wrist twist (JT6)	0.14
Mass (kg)	150	
Mounting	Floor, Ceiling	
Installation environment	Ambient temperature (°C)	0 - 45
	Relative humidity (%)	35 - 85 (No dew, nor frost allowed)
Degee of protection	Wrist: IP67 or equivalent Base axes: IP65 or equivalent	
Controller/Power requirements	F60/2.0kVA, F01/5.6kVA	

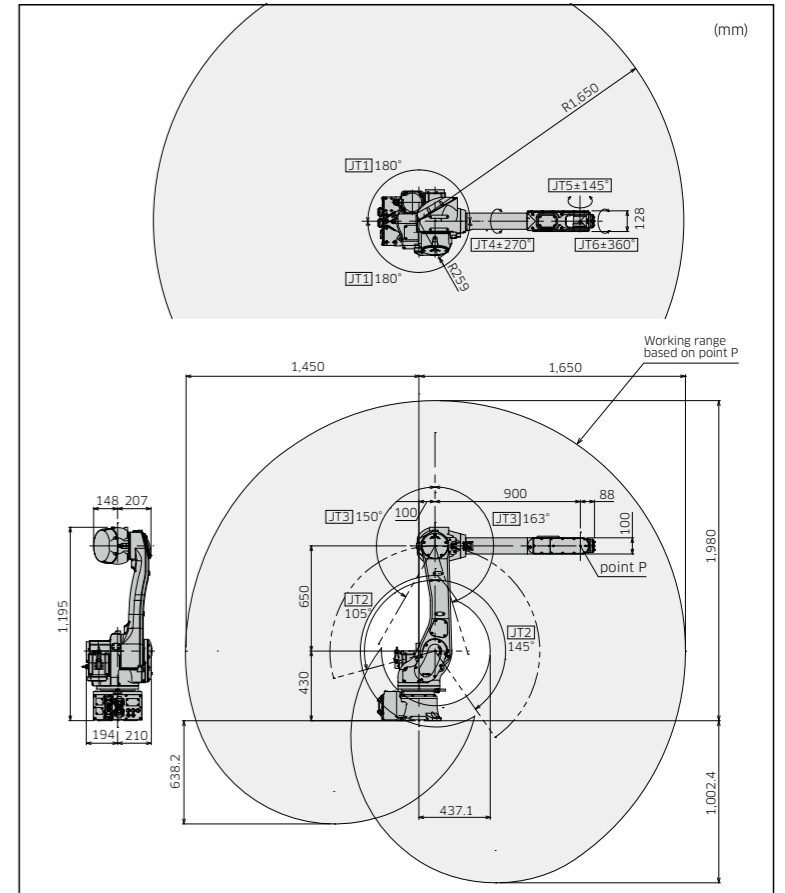

*1: Conforms to ISO9283

RS007N

Standard Specifications

Type	Articulated robot	
Degree of freedom (axes)	6	
Payload (kg)	7	
Max. reach (mm)	730	
Position repeatability*1 (mm)	±0.02	
Motion range (°)	Arm rotation (JT1)	±180
	Arm out-in (JT2)	±135
	Arm up-down (JT3)	±155
	Wrist swivel (JT4)	±200
	Wrist bend (JT5)	±125
	Wrist twist (JT6)	±360
Max. speed (°/s)	Arm rotation (JT1)	470
	Arm out-in (JT2)	380
	Arm up-down (JT3)	520
	Wrist swivel (JT4)	550
	Wrist bend (JT5)	550
	Wrist twist (JT6)	1,000
Allowable moment (N·m)	Wrist swivel (JT4)	17
	Wrist bend (JT5)	17
	Wrist twist (JT6)	10
Allowable moment of inertia (kg·m²)	Wrist swivel (JT4)	0.5
	Wrist bend (JT5)	0.5
	Wrist twist (JT6)	0.2
Mass (kg)	35	
Mounting	Floor, Ceiling	
Installation environment	Ambient temperature (°C)	0 - 45
	Relative humidity (%)	35 - 85 (No dew, nor frost allowed)
Degee of protection	Wrist : IP67 or equivalent Base axes : IP65 or equivalent	
Controller/Power requirements	F60/2.0kVA, F01/5.6kVA	

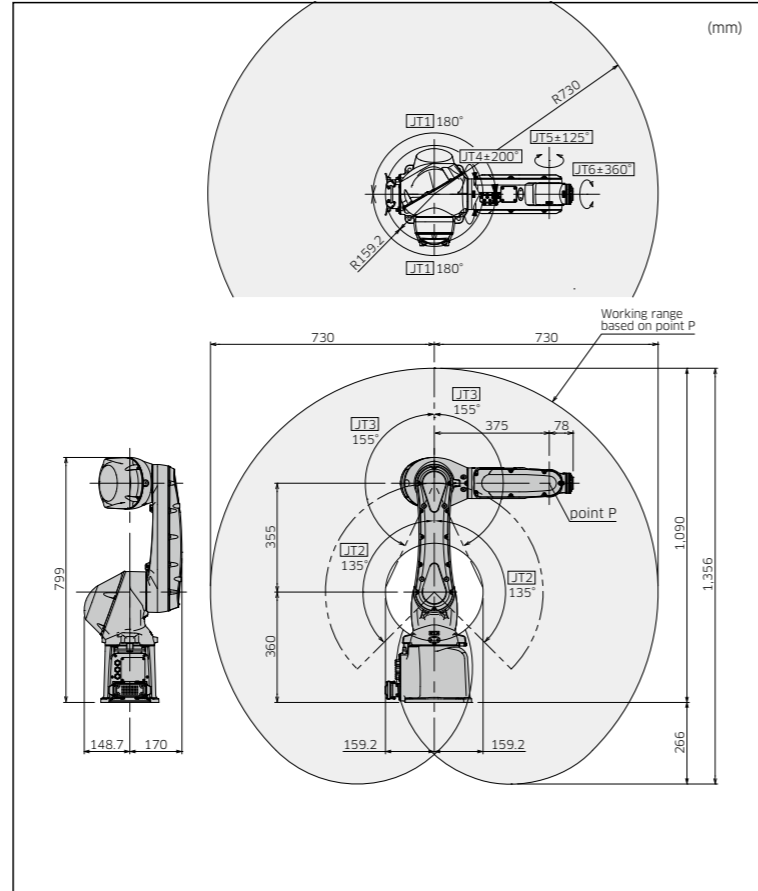

*1: Conforms to ISO9283

RS007L

Standard Specifications

Type	Articulated robot	
Degree of freedom (axes)	6	
Payload (kg)	7	
Max. reach (mm)	930	
Position repeatability*1 (mm)	±0.03	
Motion range (°)	Arm rotation (JT1)	±180
	Arm out-in (JT2)	±135
	Arm up-down (JT3)	±157
	Wrist swivel (JT4)	±200
	Wrist bend (JT5)	±125
	Wrist twist (JT6)	±360
Max. speed (°/s)	Arm rotation (JT1)	370
	Arm out-in (JT2)	310
	Arm up-down (JT3)	410
	Wrist swivel (JT4)	550
	Wrist bend (JT5)	550
	Wrist twist (JT6)	1,000
Allowable moment (N·m)	Wrist swivel (JT4)	17
	Wrist bend (JT5)	17
	Wrist twist (JT6)	10
Allowable moment of inertia (kg·m²)	Wrist swivel (JT4)	0.5
	Wrist bend (JT5)	0.5
	Wrist twist (JT6)	0.2
Mass (kg)	36	
Mounting	Floor, Ceiling	
Installation environment	Ambient temperature (°C)	0 - 45
	Relative humidity (%)	35 - 85 (No dew, nor frost allowed)
Degee of protection	Wrist : IP67 or equivalent Base axes : IP65 or equivalent	
Controller/Power requirements	F60/2.0kVA, F01/5.6kVA	

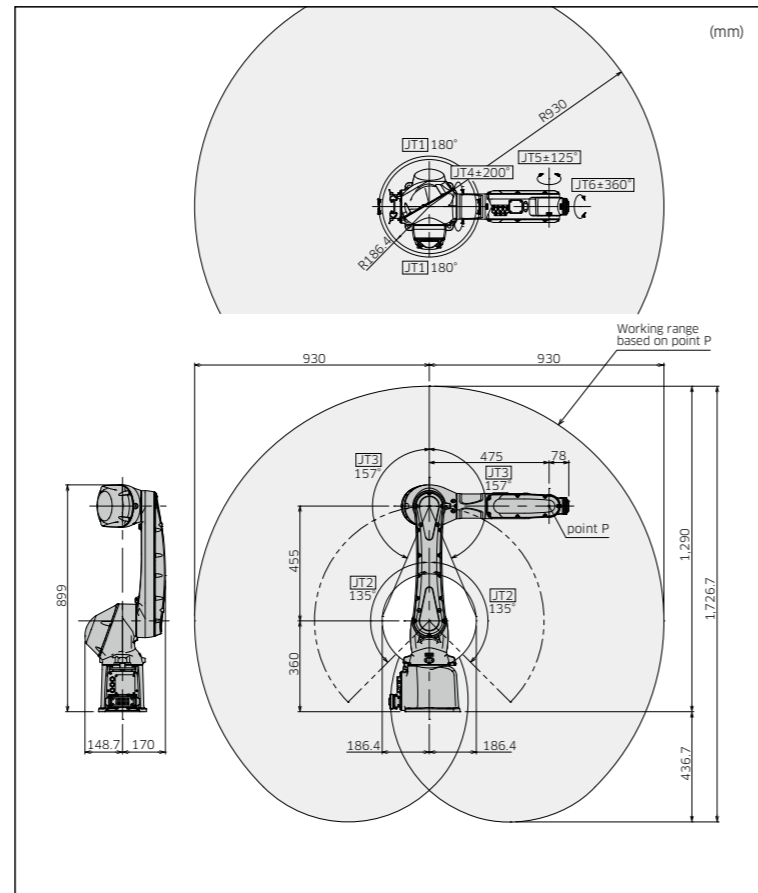

*1: Conforms to ISO9283

RS010L

Standard Specifications

Type	Articulated robot	
Degree of freedom (axes)	6	
Payload (kg)	10	
Max. reach (mm)	1,925	
Position repeatability*1 (mm)	±0.05	
Motion range (°)	Arm rotation (JT1)	±180
	Arm out-in (JT2)	+155 - -105
	Arm up-down (JT3)	+150 - -163
	Wrist swivel (JT4)	±270
	Wrist bend (JT5)	±145
	Wrist twist (JT6)	±360
Max. speed (°/s)	Arm rotation (JT1)	190
	Arm out-in (JT2)	205
	Arm up-down (JT3)	210
	Wrist swivel (JT4)	400
	Wrist bend (JT5)	360
	Wrist twist (JT6)	610
Allowable moment (N·m)	Wrist swivel (JT4)	22
	Wrist bend (JT5)	22
	Wrist twist (JT6)	10
Allowable moment of inertia (kg·m²)	Wrist swivel (JT4)	0.7
	Wrist bend (JT5)	0.7
	Wrist twist (JT6)	0.2
Mass (kg)	230	
Mounting	Floor, Ceiling	
Installation environment	Ambient temperature (°C)	0 - 45
	Relative humidity (%)	35 - 85 (No dew, nor frost allowed)
Degee of protection	Wrist : IP67 or equivalent Base axes : IP65 or equivalent	
Controller/Power requirements	F01/5.6kVA	

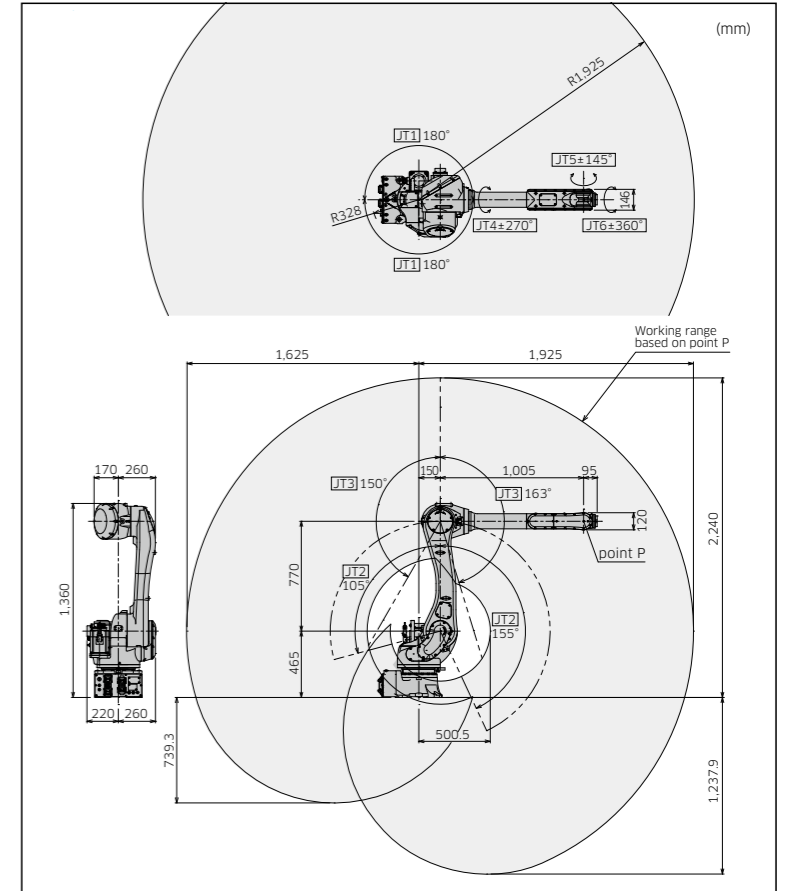

*1: Conforms to ISO9283

RS013N

Standard Specifications

Type	Articulated robot	
Degree of freedom (axes)	6	
Payload (kg)	13	
Max. reach (mm)	1,460	
Position repeatability*1 (mm)	±0.03	
Motion range (°)	Arm rotation (JT1)	±180
	Arm out-in (JT2)	+138 - -105
	Arm up-down (JT3)	+135 - -159
	Wrist swivel (JT4)	±200
	Wrist bend (JT5)	±125
	Wrist twist (JT6)	±360
Max. speed (°/s)	Arm rotation (JT1)	265
	Arm out-in (JT2)	250
	Arm up-down (JT3)	265
	Wrist swivel (JT4)	475
	Wrist bend (JT5)	475
	Wrist twist (JT6)	730
Allowable moment (N·m)	Wrist swivel (JT4)	26
	Wrist bend (JT5)	26
	Wrist twist (JT6)	10
Allowable moment of inertia (kg·m²)	Wrist swivel (JT4)	0.9
	Wrist bend (JT5)	0.9
	Wrist twist (JT6)	0.3
Mass (kg)	170	
Mounting	Floor, Ceiling	
Installation environment	Ambient temperature (°C)	0 - 45
	Relative humidity (%)	35 - 85 (No dew, nor frost allowed)
Degee of protection	IP67 or equivalent	
Controller/Power requirements	F60/2.0kVA, F01/5.6kVA	

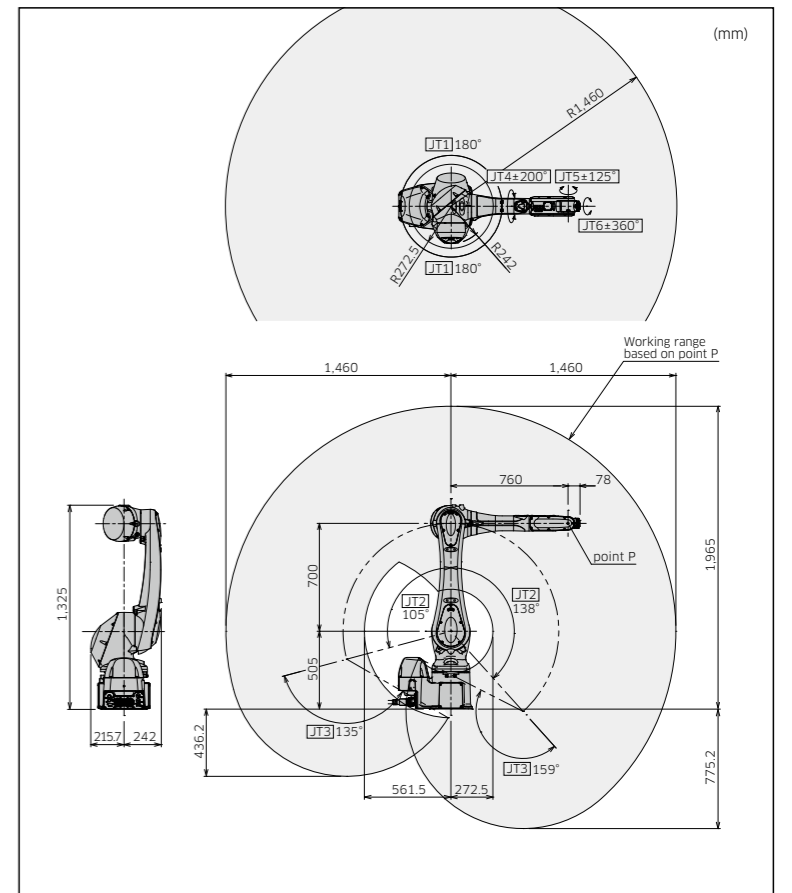

*1: Conforms to ISO9283

RS015X

Standard Specifications

Type		Articulated robot
Degree of freedom (axes)		6
Payload (kg)		15
Max. reach (mm)		3,150
Position repeatability*1 (mm)		±0.06
Motion range (°)	Arm rotation (JT1)	±180
	Arm out-in (JT2)	+140 - -105
	Arm up-down (JT3)	+135 - -155
	Wrist swivel (JT4)	±360
	Wrist bend (JT5)	±145
	Wrist twist (JT6)	±360
Max. speed (°/s)	Arm rotation (JT1)	180
	Arm out-in (JT2)	180
	Arm up-down (JT3)	200
	Wrist swivel (JT4)	410
	Wrist bend (JT5)	360
	Wrist twist (JT6)	610
Allowable moment (N·m)	Wrist swivel (JT4)	34
	Wrist bend (JT5)	34
	Wrist twist (JT6)	22
Allowable moment of inertia (kg·m²)	Wrist swivel (JT4)	0.8
	Wrist bend (JT5)	0.8
	Wrist twist (JT6)	0.25
Mass (kg)		545
Mounting		Floor, Ceiling
Installation environment	Ambient temperature (°C)	0 - 45
	Relative humidity (%)	35 - 85 (No dew, nor frost allowed)
Degree of protection		Wrist : IP67 or equivalent Base axes : IP65 or equivalent
Controller/Power requirements		F02/7.5kVA

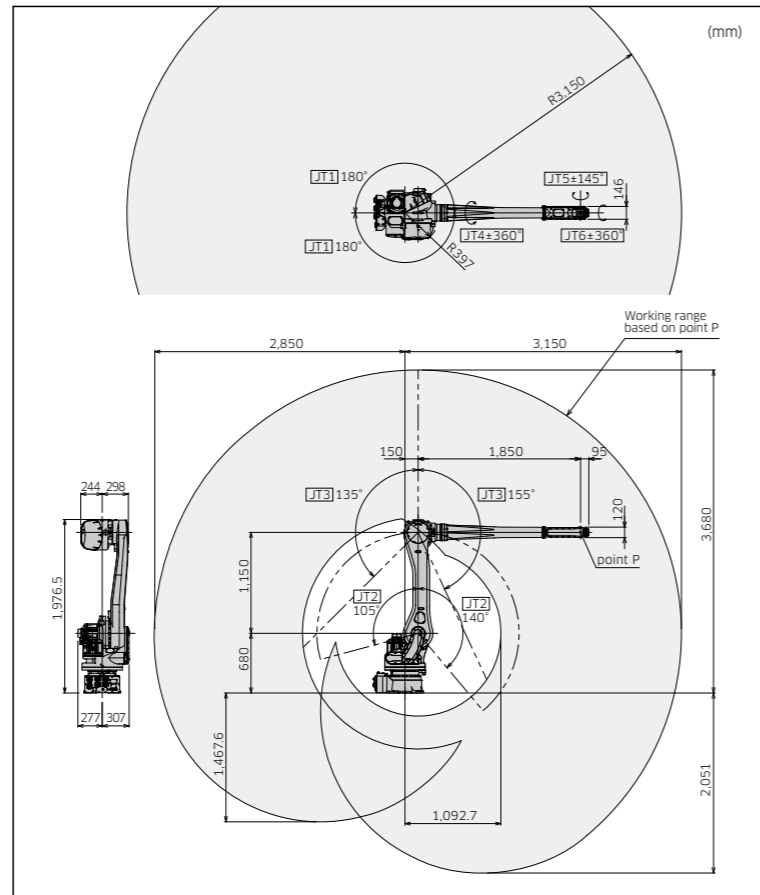

*1: Conforms to ISO9283

RS030N/RS050N/RS080N

Standard Specifications

Type		Articulated robot
Degree of freedom (axes)		6
Payload (kg)		30/50/80
Max. reach (mm)		2,100
Position repeatability*1 (mm)		±0.06
Motion range (°)	Arm rotation (JT1)	±180
	Arm out-in (JT2)	+140 - -105
	Arm up-down (JT3)	+135 - -155
	Wrist swivel (JT4)	±360
	Wrist bend (JT5)	±145
	Wrist twist (JT6)	±360
Max. speed (°/s)	Arm rotation (JT1)	180
	Arm out-in (JT2)	180
	Arm up-down (JT3)	185/185/160
	Wrist swivel (JT4)	260/260/185
	Wrist bend (JT5)	260/260/165
	Wrist twist (JT6)	360/360/280
Allowable moment (N·m)	Wrist swivel (JT4)	210/210/336
	Wrist bend (JT5)	210/210/336
	Wrist twist (JT6)	130/130/194
Allowable moment of inertia (kg·m²)	Wrist swivel (JT4)	16.8/28/34
	Wrist bend (JT5)	16.8/28/34
	Wrist twist (JT6)	6.6/11/13.7
Mass (kg)		555
Mounting		Floor, Ceiling
Installation environment	Ambient temperature (°C)	0 - 45
	Relative humidity (%)	35 - 85 (No dew, nor frost allowed)
Degree of protection		Wrist : IP67 or equivalent Base axes : IP65 or equivalent
Controller/Power requirements		F02/7.5kVA

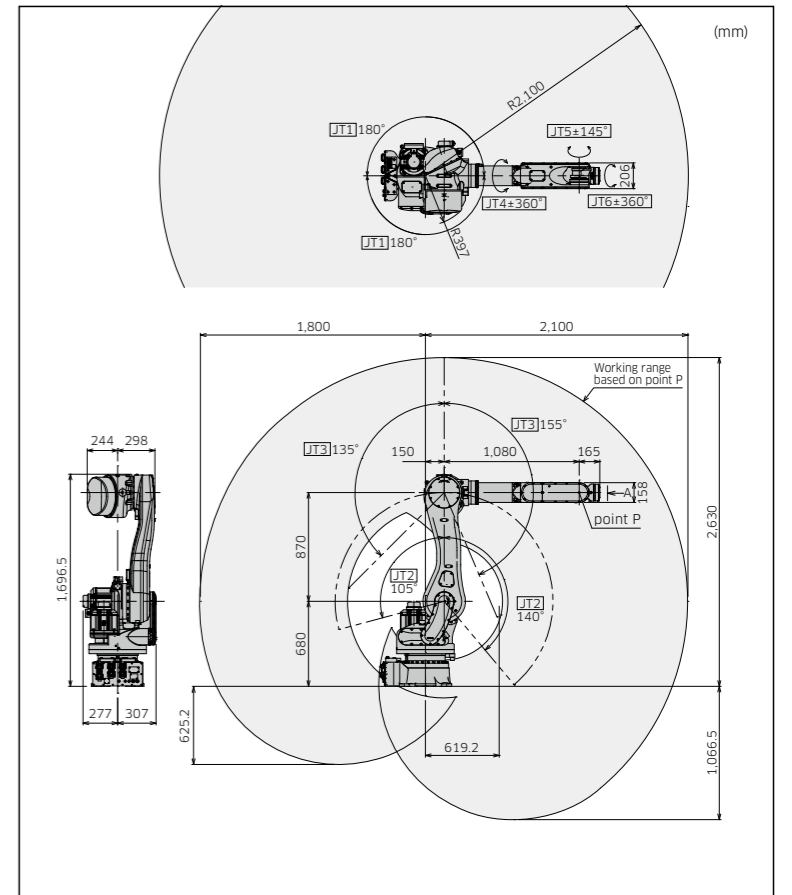

*1: Conforms to ISO9283

RS025N

Standard Specifications

Type		Articulated robot
Degree of freedom (axes)		6
Payload (kg)		25
Max. reach (mm)		1,885
Position repeatability*1 (mm)		±0.04
Motion range (°)	Arm rotation (JT1)	±180
	Arm out-in (JT2)	+131 - -100
	Arm up-down (JT3)	+145 - -161
	Wrist swivel (JT4)	±270
	Wrist bend (JT5)	±145
	Wrist twist (JT6)	±360
Max. speed (°/s)	Arm rotation (JT1)	215
	Arm out-in (JT2)	215
	Arm up-down (JT3)	270
	Wrist swivel (JT4)	420
	Wrist bend (JT5)	420
	Wrist twist (JT6)	780
Allowable moment (N·m)	Wrist swivel (JT4)	60
	Wrist bend (JT5)	60
	Wrist twist (JT6)	32
Allowable moment of inertia (kg·m²)	Wrist swivel (JT4)	2.6
	Wrist bend (JT5)	2.6
	Wrist twist (JT6)	1.3
Mass (kg)		270
Mounting		Floor, Ceiling
Installation environment	Ambient temperature (°C)	0 - 45
	Relative humidity (%)	35 - 85 (No dew, nor frost allowed)
Degree of protection		IP67 or equivalent
Controller/Power requirements		F02/7.5kVA

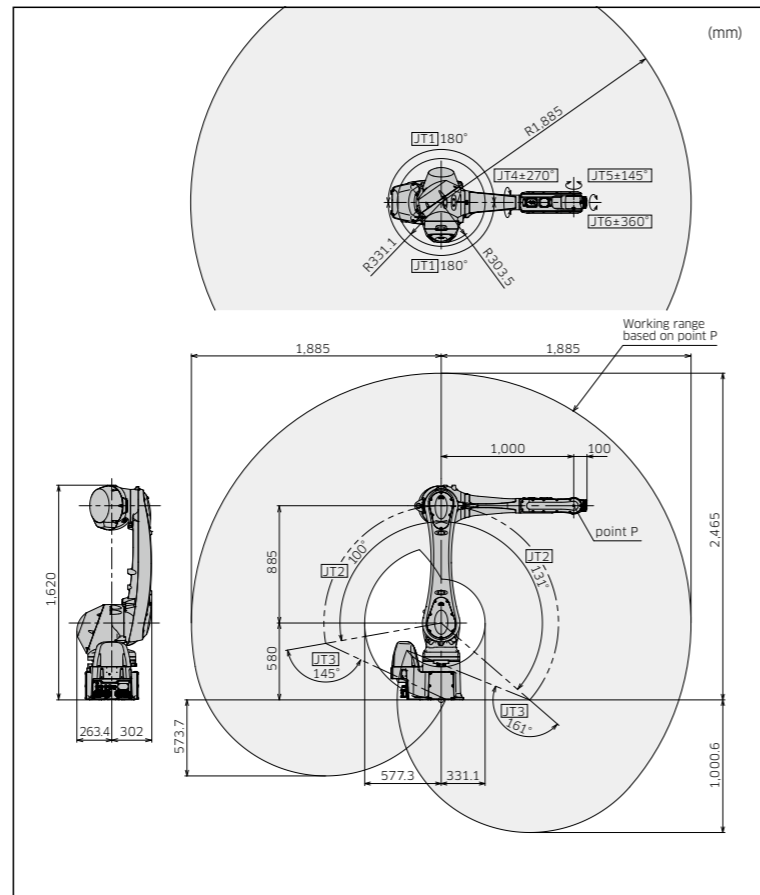

*1: Conforms to ISO9283

F60

Features

- Universal controller has common specifications to be used worldwide.
- Drastic downsizing has achieved very compact dimensions and light weight (8.3kg). It is easy for a person to carry the controller.



Standard Specifications

Dimensions (mm)	W300×D320×H130	
Type	Open type indirect cooling system (IP20 or equivalent)	
Controlled (axes)	6	
Memory capacity (MB)	16	
I/O signals	External operation	Motor power off, Hold
	Input (Channels)	16
	Output (Channels)	16
Cable length	Teach pendant (m)	5
	Robot-controller (m)	5
Mass (kg)	8.3	
Power requirements	AC200 - AC230V ±10%, 50/60Hz, 1Φ	
	Max. 2.0kVA	
Installation environment	Ambient temperature (°C)	0 - 45
	Relative humidity (%)	35 - 85 (No dew, nor frost allowed)
Teach pendant	TFT color LCD display with touch-panel, E-Stop switch, Teach lock switch, Enable switch	
Operation panel	E-stop switch, teach/repeat switch	

External view and dimensions

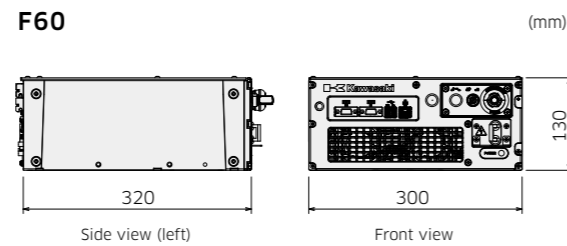

F01/F02

Features

- Dimensions and weight have been reduced from its previous E-controller.
- This universal controller has common specifications that can be used globally. (An optional transformer unit is necessary in the region where the power supply and safety standard differ.)



Standard Specifications

		F01	F02
Dimensions (mm)		W420×D530×H278	
Type		Enclosed type, indirect cooling system (IP54 or equivalent)	
Controlled (axes)		7	
Memory capacity (MB)		16	
I/O signals	External operation	Motor power off, Hold	
	Input (Channels)	32	
	Output (Channels)	32	
Cable length	Teach pendant (m)	5	
	Robot-controller (m)	5	
Mass (kg)	20	25	
Power requirements	AC200V - AC220V ±10%, 50/60Hz, 3Φ		
	AC200V - AC230V ±10%, 50/60Hz, 1Φ*1		
		Max. 5.6kVA	Max. 7.5kVA
Installation environment	Ambient temperature (°C)	0 - 45	
	Relative humidity (%)	35 - 85 (No dew, nor frost allowed)	
Teach pendant	Color LCD display with touch-panel, E-Stop switch, Teach lock switch, Enable switch		
Operation panel	E-stop switch, teach/repeat switch		

*1: 200V single phase is available for some robot models only.

External view and dimensions

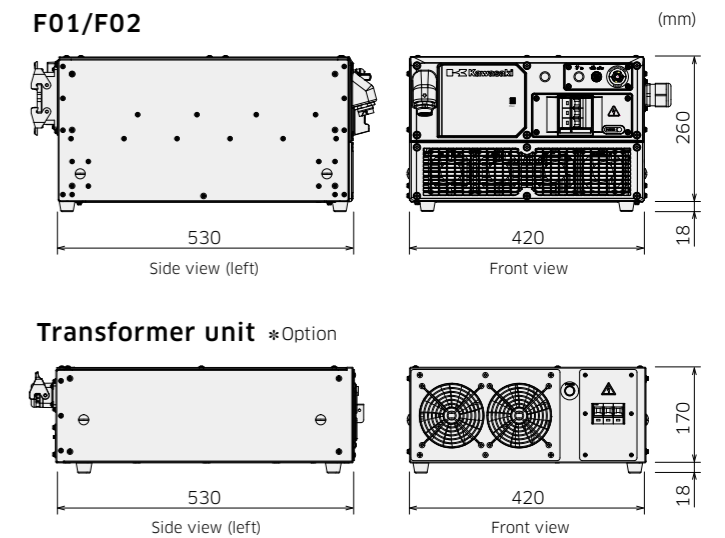

System configuration

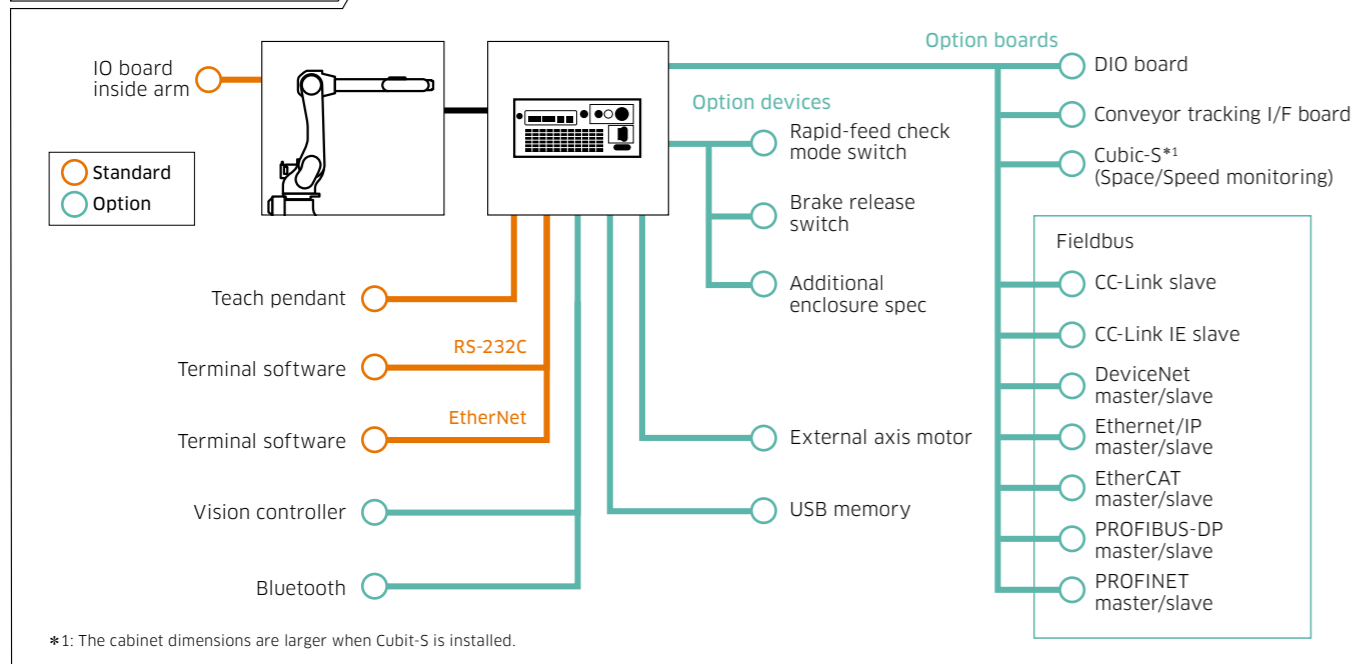

System configuration

