

PICKING ROBOTS

YF Series



Kawasaki Heavy Industries, Ltd.

Robot Business Division

Tokyo Head Office/Robot Division
1-14-5, Kaigan, Minato-ku, Tokyo 105-8315, Japan
Phone: +81-3-3435-2501 Fax: +81-3-3437-9880

Akashi Works/Robot Division
1-1, Kawasaki-cho, Akashi, Hyogo 673-8666, Japan
Phone: +81-78-921-2946 Fax: +81-78-923-6548

Nishi-Kobe Works/Robot Division
234, Matsumoto, Hasetani-cho, Nishi-ku, Kobe, Hyogo 651-2239, Japan
Phone: +81-78-915-8136 Fax: +81-78-915-8274

Kawasaki Robotics website
<https://kawasakirobotics.com/>



Kawasaki Robostage (showroom)
<https://kawasakirobotics.com/jp-sp/robostage/en/>



Global Network

Kawasaki Robotics (USA), Inc.
28140 Lakeview Drive, Wixom, MI 48393, U.S.A.
Phone: +1-248-446-4100 Fax: +1-248-446-4200

Kawasaki Robotics (UK) Ltd.
Unit 4 Easter Court, Europa Boulevard, Westbrook
Warrington Cheshire, WA5 7ZB, United Kingdom
Phone: +44-1925-71-3000 Fax: +44-1925-71-3001

Kawasaki Robotics GmbH
Im Taubental 32, 41468 Neuss, Germany
Phone: +49-2131-34260 Fax: +49-2131-3426-22

Kawasaki Robotics Korea, Ltd.
Room 1408, 135, Gasan digital 2-ro, Geumcheon-gu, Seoul,
Republic of Korea
Phone: +82-32-821-6941 Fax: +82-32-821-6947

Kawasaki Robotics (Tianjin) Co., Ltd.
1-2/F, Building 6, No.19 Xinhuan Road, TEDA, China
Phone: +86-22-5983-1888 Fax: +86-22-5983-1889

Taiwan Kawasaki Robot Center
3F, No.31, Ln.216, Gongyuan Rd., Hsinchu City
30069, Taiwan(R.O.C)
Phone: +886-3-562-0518

Kawasaki Robotics (Thailand) Co., Ltd.
(Rayong Robot Center)
119/9 Moo 4 T.Pluak Daeng, A.Pluak Daeng, Rayong 21140
Thailand
Phone: +66-38-955-040-58 Fax: +66-38-955-145

Singapore Kawasaki Robot Center
100G Pasir Panjang Road #06-10
Singapore 118523
Phone: +65-6513-3145

Kawasaki Robotics India Pvt. Ltd.
1/5, Village-Khandsa, Khasra No. 1364,599/2/2/1,
Hero Honda Chowk,Gurgaon-122001, Haryana
Phone: +91-124-608-5500



CAUTIONS TO BE TAKEN TO ENSURE SAFETY

- For any persons involved with the operation / servicing of your system, including Kawasaki Robot, they must strictly observe all safety regulations at all times. Please carefully read the Manuals and other related safety documents.
- Products described in this catalogue are general industrial robots. Therefore, if a customer wishes to use the Robot for special purposes, which might endanger operators, or if the Robot has any problems, please contact us. We will be happy to help you.
- Please be careful as Photographs illustrated in this catalogue are frequently taken after the removal of safety fences and other safety devices stipulated in the safety regulations from the Robot operation system.

Picking Robots

The Y series pick & place robots are used in food, pharmaceutical, cosmetic, electric, electronics and machine parts industries.
The YF002N is compact, while the YF003N has a long motion range.

YF series

[Applications]



Features

- The compact YF002N and long motion-range YF003N achieve high-speed pick & place. Both models use grease and oil for food-processing machinery.
- Wash-down with acid or alkaline cleanser is possible (the YF003N).

YF002N



YF003N



YF002N

Standard Specifications

Type	Parallel link type
Degree of freedom (axes)	4
Payload (kg)	2
Position repeatability*1 (mm)	±0.04
Angular repeatability (°)	±0.1
Motion range (mm)	φ600×H200
Cycle Time*2 (Payload)	0.3s (0.5kg), 0.36s (2kg)
Mass (kg)	60
Mounting	Ceiling
Installation environment	Ambient temperature (°C) 10 - 35 Relative humidity (%) 35 - 85 (No dew, nor frost allowed)
Degee of protection	IP65 or equivalent
Controller/Power requirements	F01/5.6 kVA

*1: Conforms to ISO9283
*2: Motion Pattern (25mm up, 305mm horizontal, 25mm down in a to-and-fro motion)

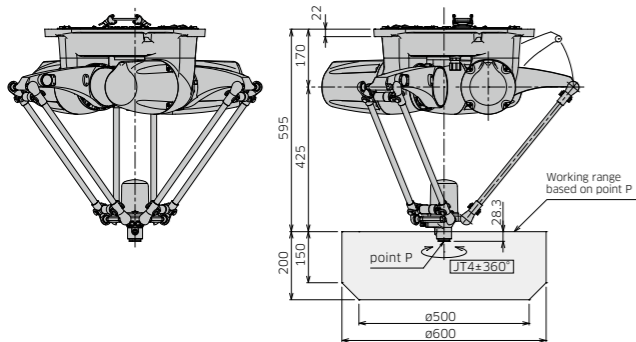

Controller

F01

Features

- The F01 controller has common specifications to be used globally.
- Performance and expandability have been greatly enhanced from its previous E-controller. Yet, the size and weight are much smaller.

Standard Specifications

Dimensions (mm)	W420×D530×H278	
Type	Enclosed type, indirect cooling system (IP54 or equivalent)	
Controlled (axes)	6	
Memory capacity (MB)	16	
I/O signals	External operation	Motor power off, Hold
	Input (Channels)	32
	Output (Channels)	32
Cable length	Teach pendant (m)	5
	Robot-controller (m)	5
Mass (kg)	20	
Power requirements	AC200V - AC220V ±10%, 50/60Hz, 3Φ AC200V - AC230V ±10%, 50/60Hz, 1Φ *1 Max. 5.6kVA	
Installation environment	Ambient temperature (°C)	0 - 45
	Relative humidity (%)	35 - 85 (No dew, nor frost allowed)
Teach pendant	Color LCD display with touch-panel, E-Stop switch, Teach lock switch, Enable switch	
Operation panel	E-stop switch, teach/repeat switch	

*1: 200V single phase is available for some robot models only.



External view and Dimensions

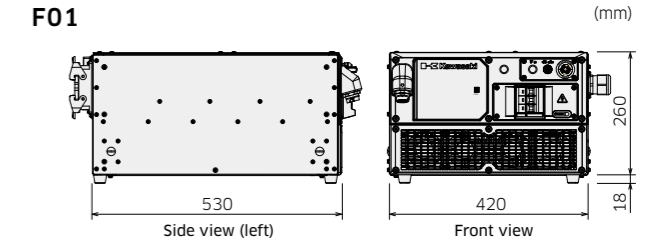

Transformer unit *Option

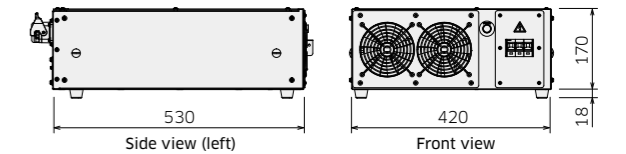

YF003N

Standard Specifications

Type	Parallel link type
Degree of freedom (axes)	4
Payload (kg)	3
Position repeatability*1 (mm)	±0.1
Angular repeatability (°)	±0.1
Motion range (mm)	φ1,300×H500
Cycle Time*2 (Payload)	0.27s (1kg), 0.45s (3kg)
Mass (kg)	145
Mounting	Ceiling
Installation environment	Ambient temperature (°C) 0 - 45 Relative humidity (%) 35 - 85 (No dew, nor frost allowed)
Degee of protection	IP65 or equivalent
Controller/Power requirements	F01/5.6kVA

*1: Conforms to ISO9283
*2: Motion Pattern (25mm up, 305mm horizontal, 25mm down in a to-and-fro motion)

