

Kawasaki Heavy Industries, Ltd

Robot Business Division

Tokyo Head Office/Robot Division

1-14-5, Kaigan, Minato-ku, Tokyo 105-8315, Japan
Phone: +81-3-3435-2501 Fax: +81-3-3437-9880

Akashi Works/Robot Division

1-1, Kawasaki-cho, Akashi, Hyogo 673-8666, Japan
Phone: +81-78-921-2946 Fax: +81-78-923-6548

Nishi-Kobe Works/Robot Division

234, Matsumoto, Hasetani-cho, Nishi-ku, Kobe, Hyogo 651-2239, Japan
Phone: +81-78-915-8247 Fax: +81-78-915-8239

Kawasaki Robotics website

<https://kawasakirobotics.com/>



Kawasaki Robotics brand site XYZ

<https://robotics.kawasaki.com/ja1/xyz/en/>



Kawasaki Robostage (showroom)

<https://robotics.kawasaki.com/ja1/robostage/en.html>



Global Network

Kawasaki Robotics (USA), Inc.

28140 Lakeview Drive, Wixom, MI 48393, U.S.A.
Phone: +1-248-446-4100 Fax: +1-248-446-4200

Kawasaki Robotics (UK) Ltd.

Unit 4 Easter Court, Europa Boulevard, Westbrook
Warrington Cheshire, WA5 7ZB, United Kingdom
Phone: +44-1925-71-3000 Fax: +44-1925-71-3001

Kawasaki Robotics GmbH

Im Taubental 32, 41468 Neuss, Germany
Phone: +49-2131-34260 Fax: +49-2131-3426-22

Kawasaki Robotics Korea, Ltd.

43, Namdong-daero 215beon-gil, Namdong-gu, Incheon,
21633, Korea
Phone: +82-32-821-6941 Fax: +82-32-821-6947

Kawasaki Robotics (Tianjin) Co., Ltd.

1-2/F, Building 6, No.19 Xinhuan Road, TEDA, China
Phone: +86-22-5983-1888 Fax: +86-22-5983-1889

Taiwan Kawasaki Robot Center

3F, No.31, Ln.216, Gongyuan Rd., Hsinchu City
30069, Taiwan(R.O.C)
Phone: +886-3-562-0518

Kawasaki Motors Enterprise (Thailand) Co., Ltd.

(Rayong Robot Center)
119/10 Moo 4 T.Pluaek Daeng, A.Pluaek Daeng, Rayong 21140
Thailand
Phone: +66-38-955-040-58 Fax: +66-38-955-145

Singapore Kawasaki Robot Center

100G Pasir Panjang Road #06-10
Singapore 118523
Phone: +65-6513-3145

Kawasaki Robotics India Pvt. Ltd.

Plot No. 136, Sector-37, Pace City 1,
Gurgaon, 122101 Haryana, India
Phone: +91-124-437-1845

Kawasaki Robot

Dual-arm Collaborative Robots

Small-to-medium robots
up to 80kg payload

Large robots
up to 300kg payload

Extra large robots
up to 1,500kg payload

Dual-arm Collaborative robots

Explosion-proof painting robots

Sealing robots

Arc welding robots

Palletizing robots

Medical & pharmaceutical robots

Picking robots

Wafer transfer robots



CAUTIONS TO BE TAKEN TO ENSURE SAFETY

- For those persons involved with the operation / service of your system, including Kawasaki Robot, they must strictly observe all safety regulations at all times. They should carefully read the Manuals and other related safety documents.
- Products described in this catalogue are general industrial robots. Therefore, if a customer wishes to use the Robot for special purposes, which might endanger operators or if the Robot has any problems, please contact us. We will be pleased to help you.
- Be careful as Photographs illustrated in this catalogue are frequently taken after removing safety fences and other safety devices stipulated in the safety regulations from the Robot operation system.

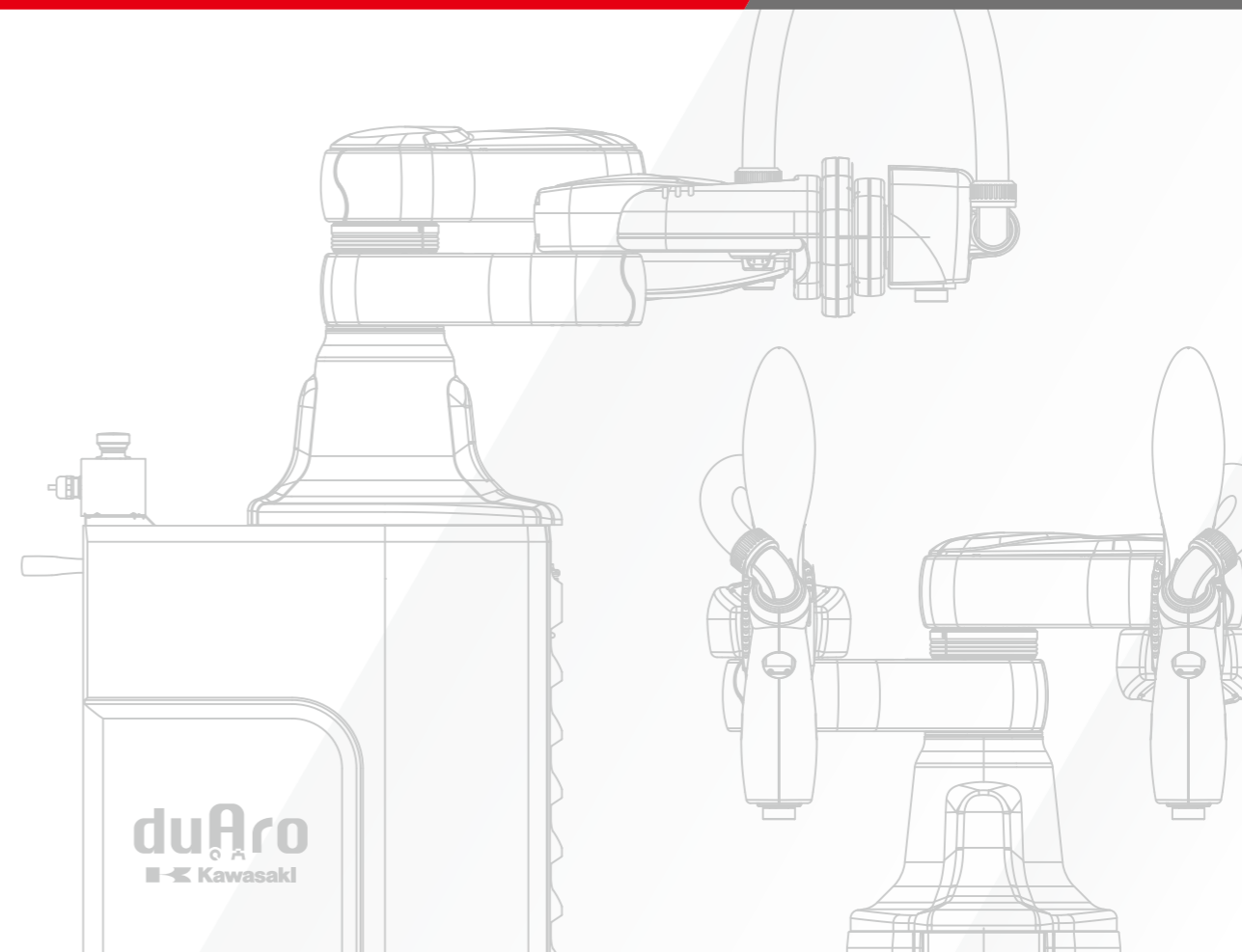

Dual-arm Collaborative Robots

Kawasaki's original collaborative duAro is a dual-arm type robot. The collaborative robot enables humans and robots to work together in the same workspace without safety fences. Kawasaki offers simple and easy-to-install robots for diverse applications.

duAro series



duAro 1



duAro 2



Features

- Space-saving without safety fences.*
- With its two arms, duAro can perform as efficient tasks as human workers.
- Easy programming using a tablet and the direct teaching function.

* : Users are required to carry out a safety risk assessment before use.

Applications

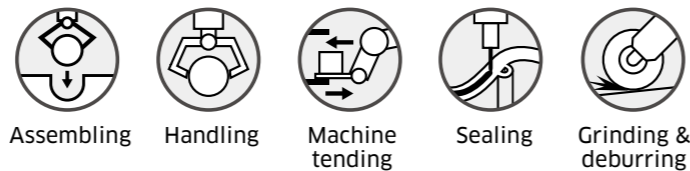

duAro 1

Standard Specifications

Type	Articulated robot	
Degree of freedom (axes)	4 × 2 arms	
Payload (kg)	2 × 2 arms	
Max. reach (mm)	760	
Position repeatability (mm)	±0.05	
Motion range	Arm 1 (lower arm)	Arm 2 (upper arm)
	Arm rotation (°)	±170 (JT1) -140 - +500 (JT2)
	Arm up-down*1 (mm)	0 - +150 (JT3) 0 - +150 (JT3)
Wrist swivel*1 (°)	±360 (JT4)	±360 (JT4)
Allowable moment (N·m)	Wrist axis (JT4)	3.9
Allowable moment of inertia (kg·m ²)	Wrist axis (JT4)	0.086
Mass (kg)	Approx. 210 (including controller. Excluding options)	
Mounting	Floor	
Installation environment	Ambient temperature (°C)	5 - 40
	Relative humidity (%)	35 - 85 (No dew, nor frost allowed)
Controller/Power requirements	F61/2.0kVA	

*1 : Specification varies in case of other options or conversion

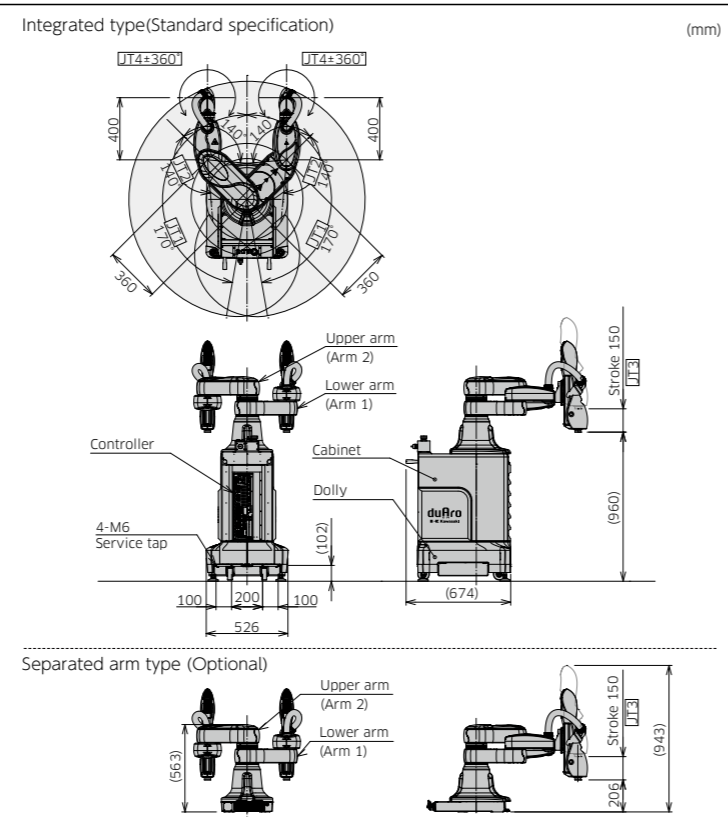

F61

Standard Specifications

Dimensions (mm)	W429×D445×H130	
Type	Enclosed structure	
Controlled (axes)	8	
Memory capacity (MB)	16	
I/O signals	Input (Channels)	16
	Output (Channels)	16
Power requirements	AC200-230V ±10%, 50/60Hz ±2%, Single phase, Max. 2.0kVA	
	Class D (Category3) earth connection, Smaller than 100 Ω (robot-dedicated earth), leakage current 10mA	
Installation environment	Ambient temperature (°C)	0 - 40*1
	Relative humidity (%)	35 - 85 (No dew, nor frost allowed)*1
Operation panel	Manual-auto switch, Start-stop switch, E-stop switch	

*1 : Please contact Kawasaki for usage specified other than the above.

External view and dimensions

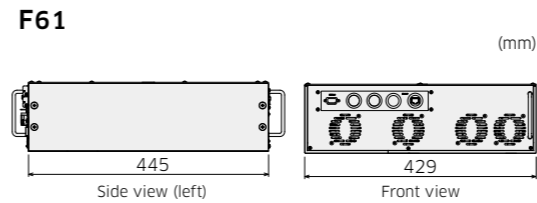

System configuration

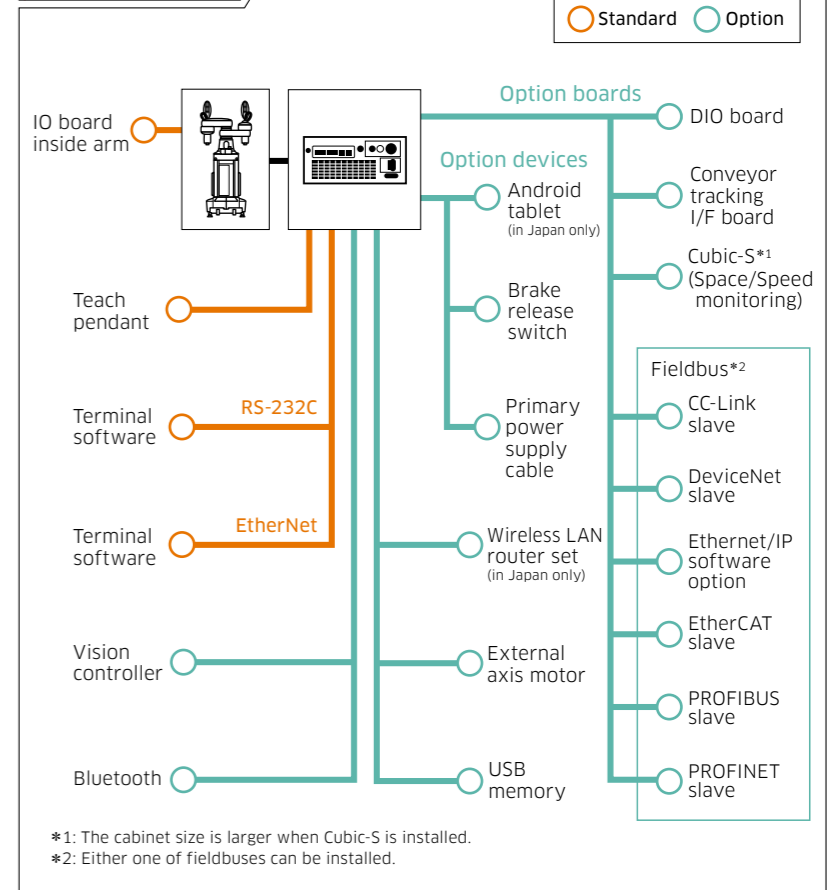

duAro 2

Standard Specifications

Type	Articulated robot	
Degree of freedom (axes)	4 × 2 arms	
Payload (kg)	3 × 2 arms	
Max. reach (mm)	785	
Position repeatability (mm)	±0.05	
Motion range	Arm 1 (lower arm)	Arm 2 (upper arm)
	Arm rotation (°)	±170 (JT1) -140 - +500 (JT2)
	Arm up-down*1 (mm)	0 - +550 (JT3) 0 - +550 (JT3)
Wrist swivel*1 (°)	±360 (JT4)	±360 (JT4)
Allowable moment (N·m)	Wrist axis (JT4)	3.9
Allowable moment of inertia (kg·m ²)	Wrist axis (JT4)	0.086
Mass (kg)	Approx. 220 (including controller. Excluding options)	
Mounting	Floor	
Installation environment	Ambient temperature (°C)	5 - 40
	Relative humidity (%)	35 - 85 (No dew, nor frost allowed)
Controller/Power requirements	F61/2.0kVA	

*1 : Specification varies in case of other options or conversion

