



Standard Specifications

MG15HL-B

1st ed. 24-Mar-17
3rd ed. 05-Mar-21

Kawasaki Heavy Industries, Ltd.
Robot Business Division

Specification number : 90151-0180DEC

Robot specifications

1. Model	MG15HL-B																						
2. Type	Articulated robot																						
3. Degree of freedom	6 axes																						
4. Max. payload	1,500 kg																						
5. Max. reach	4,005 mm																						
6. Max. applying force	15,000 N The value depends on usage conditions. If detailed data is required for your application, please contact Kawasaki.																						
7. Position repeatability	±0.10 mm (wrist flange surface) conforms to ISO 9283																						
8. Axis specification	<table border="1"> <thead> <tr> <th>Operating axis</th> <th>Motion range</th> <th>Max. speed</th> </tr> </thead> <tbody> <tr> <td>Arm rotation (JT1)</td> <td>±150°</td> <td>65° /s</td> </tr> <tr> <td>Arm out-in (JT2)</td> <td>+ 90° - - 40°</td> <td>33.5° /s</td> </tr> <tr> <td>Arm up-down (JT3)</td> <td>+ 30° - - 110° *</td> <td>37.5° /s</td> </tr> <tr> <td>Wrist swivel (JT4)</td> <td>±360°</td> <td>36° /s</td> </tr> <tr> <td>Wrist bend (JT5)</td> <td>±120°</td> <td>36° /s</td> </tr> <tr> <td>Wrist twist (JT6)</td> <td>±360°</td> <td>80° /s</td> </tr> </tbody> </table> <p>Note* The value depends on load mass and load torque.</p>		Operating axis	Motion range	Max. speed	Arm rotation (JT1)	±150°	65° /s	Arm out-in (JT2)	+ 90° - - 40°	33.5° /s	Arm up-down (JT3)	+ 30° - - 110° *	37.5° /s	Wrist swivel (JT4)	±360°	36° /s	Wrist bend (JT5)	±120°	36° /s	Wrist twist (JT6)	±360°	80° /s
Operating axis	Motion range	Max. speed																					
Arm rotation (JT1)	±150°	65° /s																					
Arm out-in (JT2)	+ 90° - - 40°	33.5° /s																					
Arm up-down (JT3)	+ 30° - - 110° *	37.5° /s																					
Wrist swivel (JT4)	±360°	36° /s																					
Wrist bend (JT5)	±120°	36° /s																					
Wrist twist (JT6)	±360°	80° /s																					
9. Load capacity of wrist	<table border="1"> <thead> <tr> <th></th> <th>Max. torque</th> <th>Moment of inertia*</th> </tr> </thead> <tbody> <tr> <td>JT4</td> <td>15,000 N·m</td> <td>2,250 kg·m²</td> </tr> <tr> <td>JT5</td> <td>15,000 N·m</td> <td>2,250 kg·m²</td> </tr> <tr> <td>JT6</td> <td>4,410 N·m</td> <td>1,200 kg·m²</td> </tr> </tbody> </table> <p>Note* Each value in this table shows allowable moment of inertia of JT4/JT5/JT6 when max. allowed torque is applied to each axis. If more detailed data is required for your application, please contact Kawasaki.</p>			Max. torque	Moment of inertia*	JT4	15,000 N·m	2,250 kg·m ²	JT5	15,000 N·m	2,250 kg·m ²	JT6	4,410 N·m	1,200 kg·m ²									
	Max. torque	Moment of inertia*																					
JT4	15,000 N·m	2,250 kg·m ²																					
JT5	15,000 N·m	2,250 kg·m ²																					
JT6	4,410 N·m	1,200 kg·m ²																					
10. Mass	6,550 kg (without options)																						
11. Mounting	Floor mounting																						
12. Installation Environment	Ambient Temperature: 0 - 45 °C																						
	Relative Humidity: 35 - 85 % (with no dew condensation)																						
13. Color	Munsell 10GY9/1 equivalent																						
14. Options	Mechanical stopper	Adjustable stopper JT1																					
	Solenoid valve	Double solenoid valve ×2, Double solenoid valve ×3																					
	Option harness	Type C0, Type H0(NPN), Type H0(PNP), Type E0(NPN), Type E0(PNP)																					
	Air cleaning	Filter, Regulator, Mistseparator																					
	Color																						

Consult Kawasaki about maintenance parts and spare parts.

Consult Kawasaki about your application because the motor could become high temperature depending on your application.

Upper motion range limit of arm up-down (JT3)

Upper motion range limit of JT3 axis varies depending on load mass (M) and length from JT4(5) axis rotation center to load center of gravity (L_{4,5}). This Length is limited by max. load torque. Upper motion range limit of JT3 axis can be calculated by the expression below. A relation among load mass, this length and upper motion range limit of JT3 axis is shown on Figure 1.

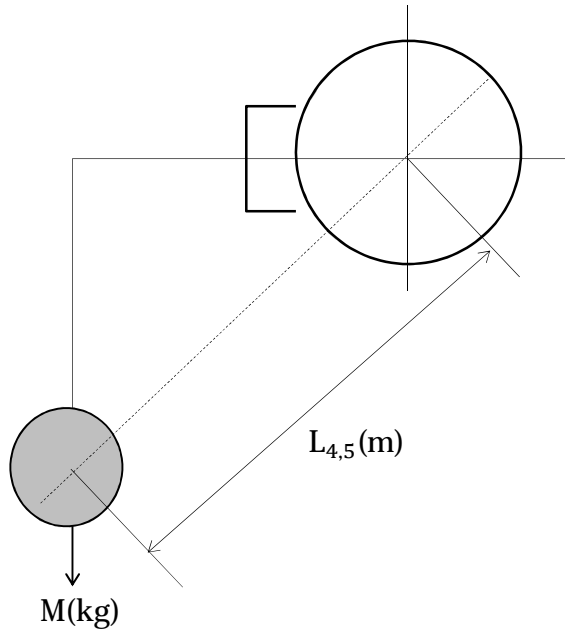

$$\theta_{max} = \frac{53362 - 18.290 \times M - L_{4,5} \times M \times 9.8}{825.343 - 0.178 \times M}$$

IF $\theta_{max} \geq 30^\circ$, then $\theta_{max} = 30^\circ$

- θ_{MAX} (°) :Upper motion range limit of JT3 axis
- M (kg) :Load mass (including workpiece)
- L_{4,5} (m) :Length from JT4(5) axis rotation center to load center of gravity

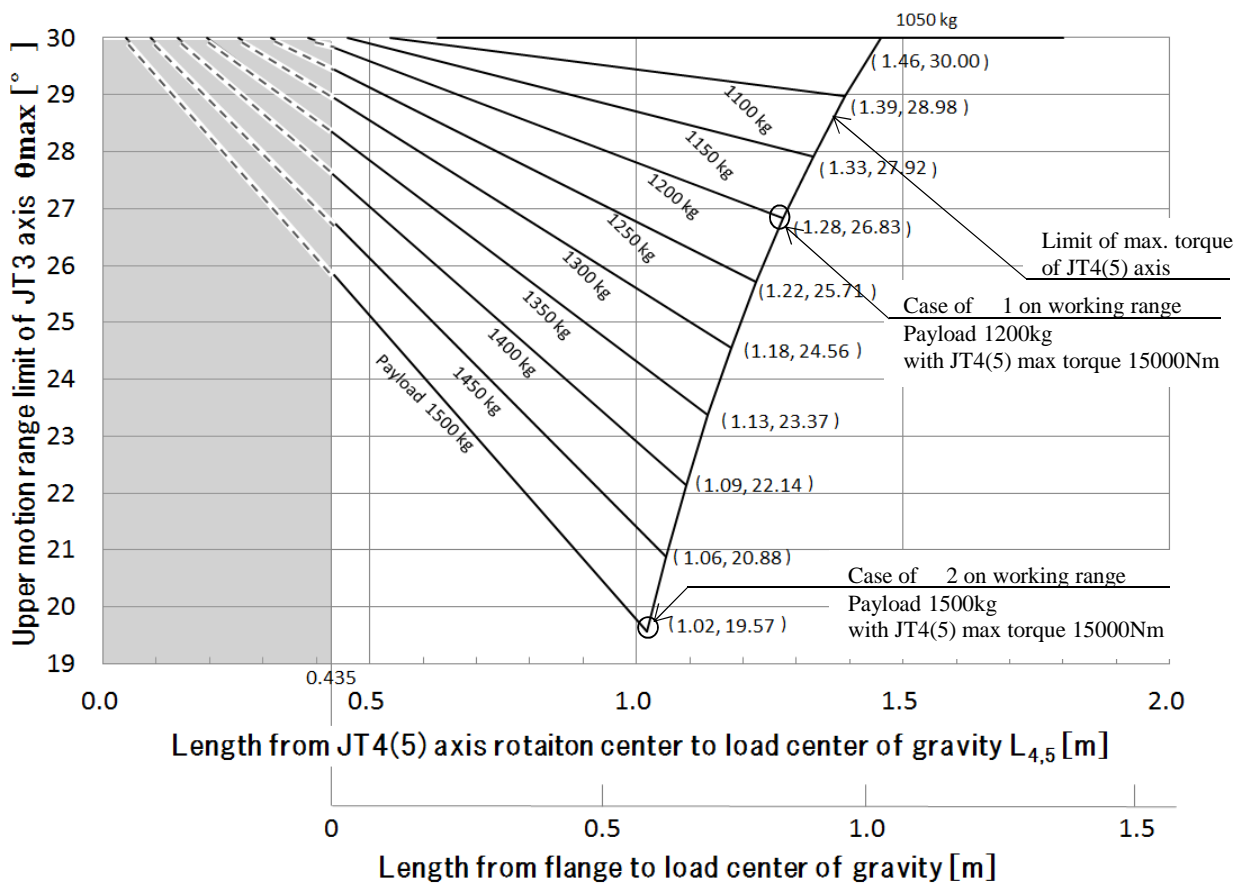
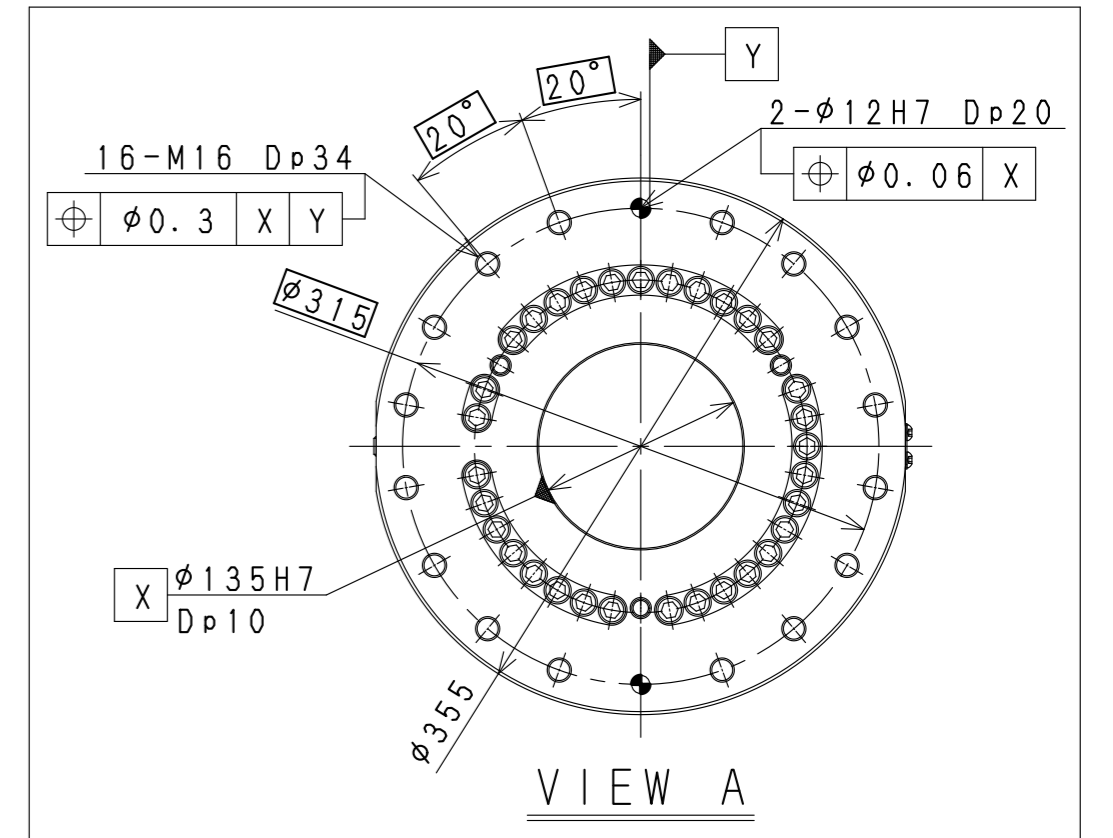
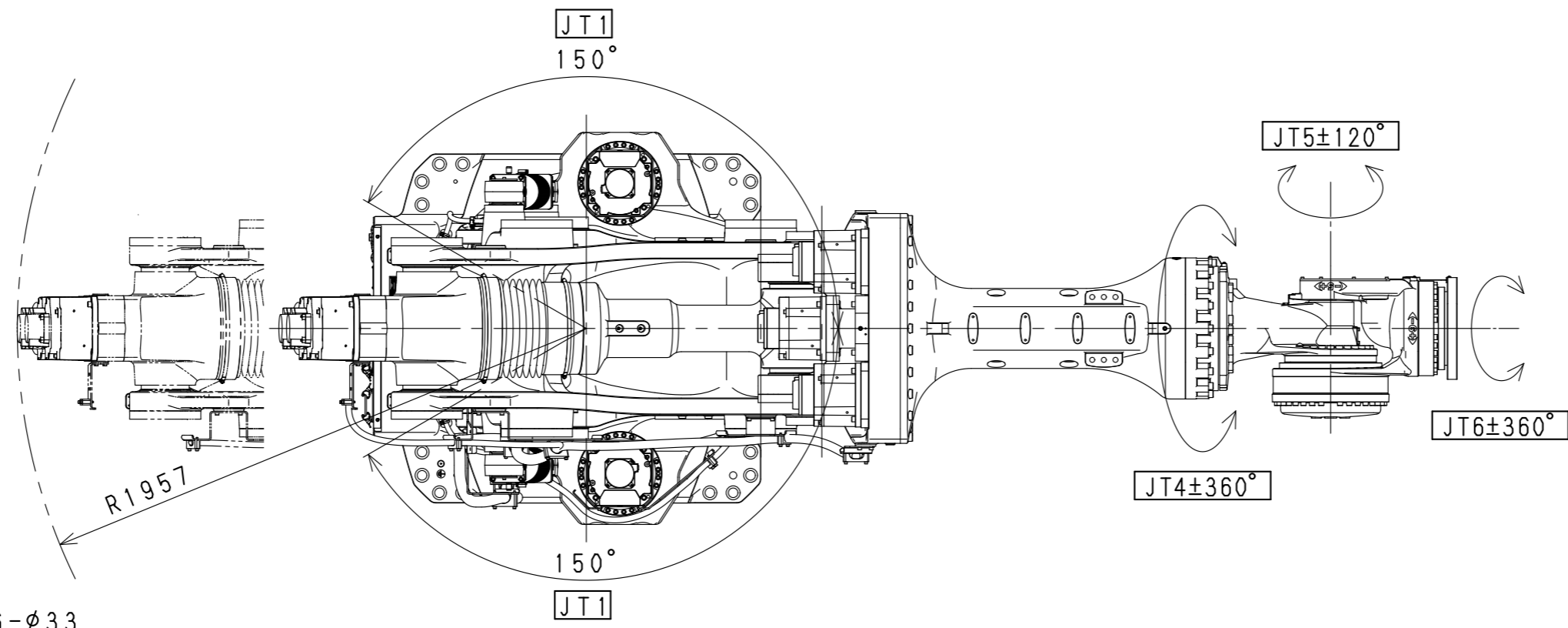
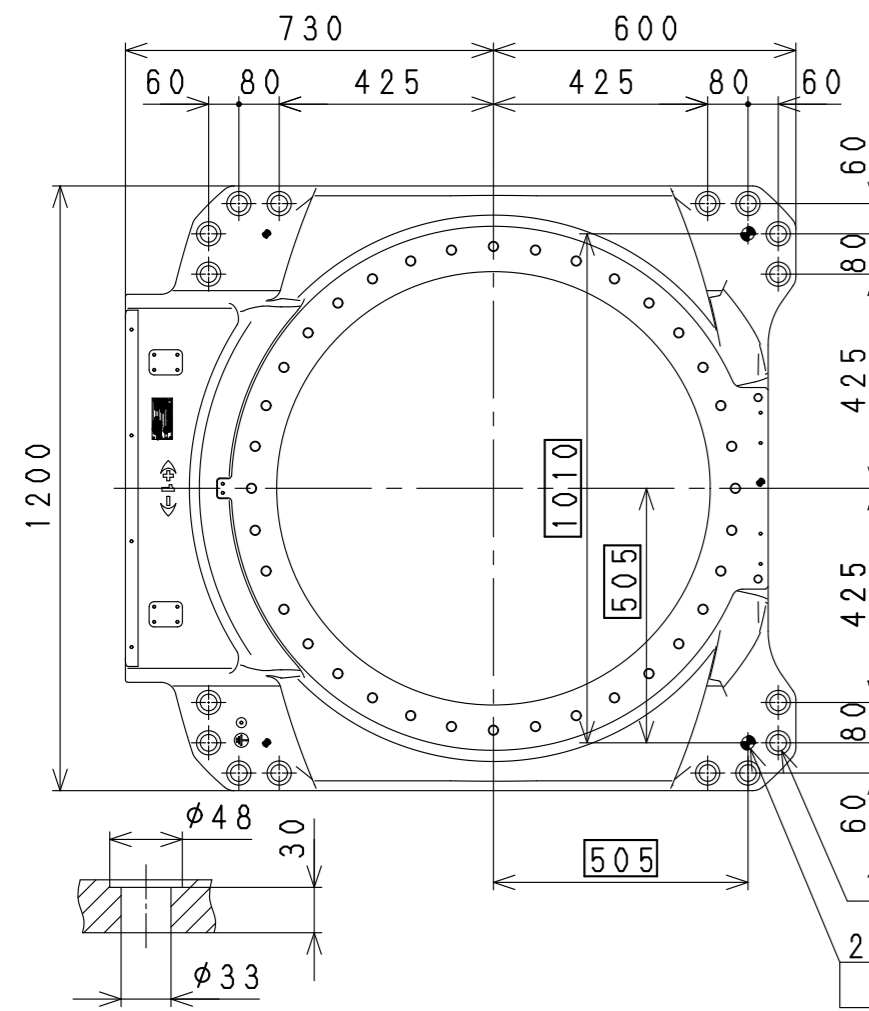
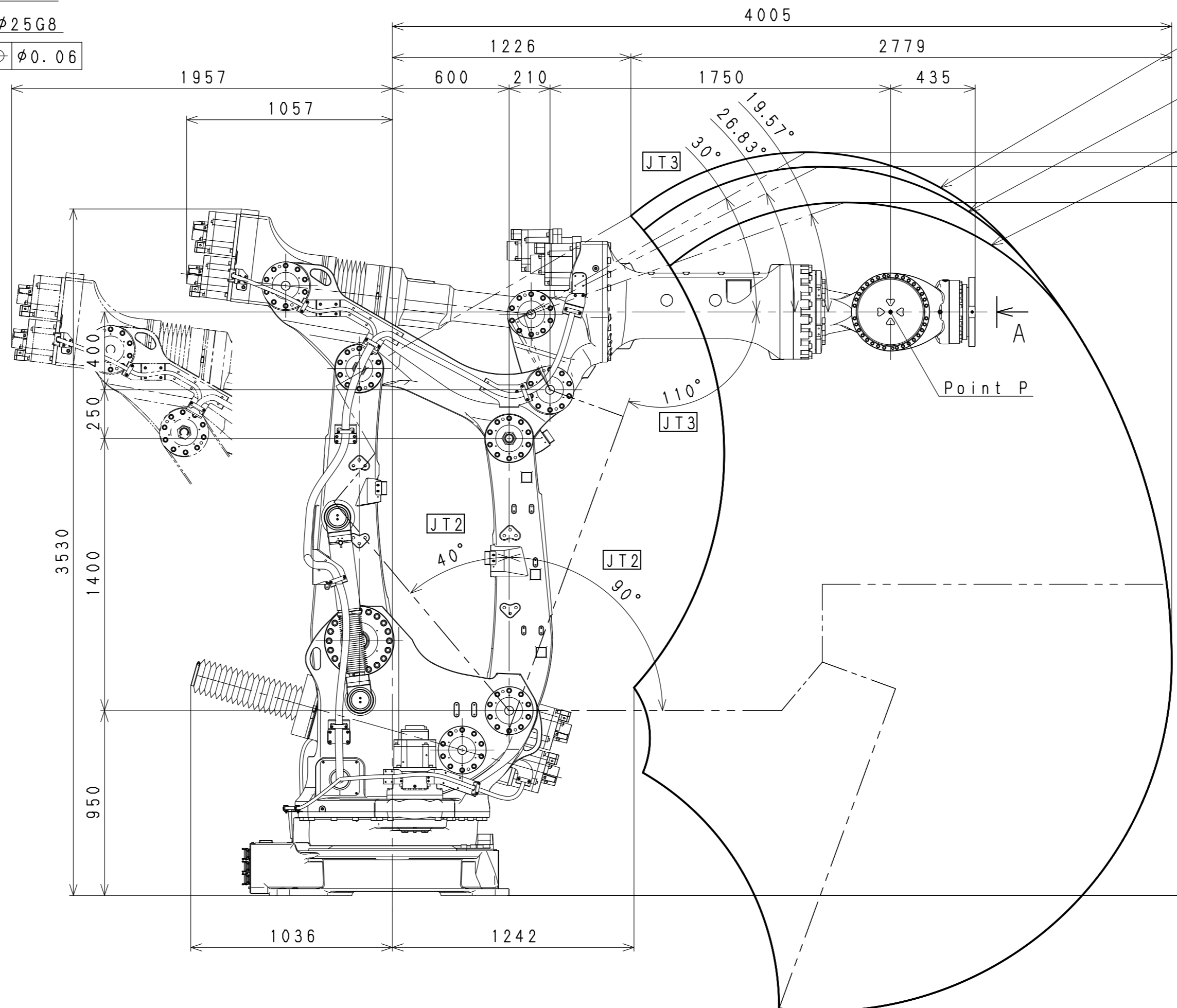
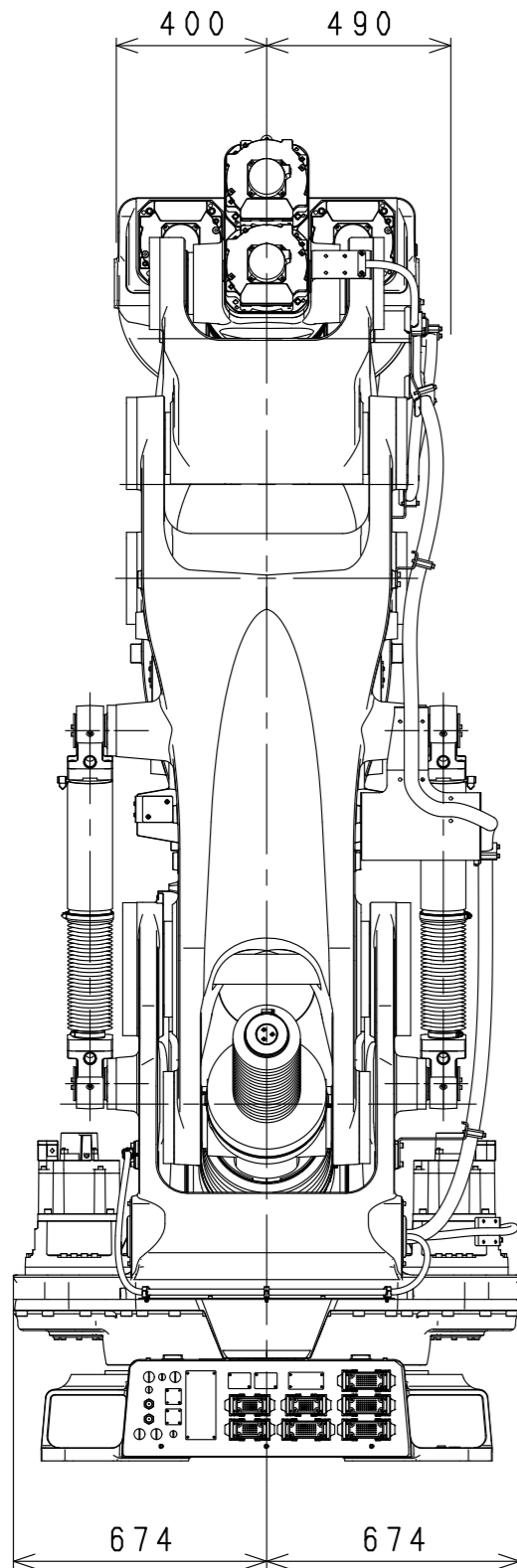

Figure 1 Relationship of load mass, length from JT4(5) axis rotation center to load center of gravity and upper motion range limit of JT3 axis



Installation Dimensions



Max. working range based on point P
Working range of 1200kg payload with max. torque based on point P (※1)
Working range of 1500kg payload with max. torque based on point P (※2)

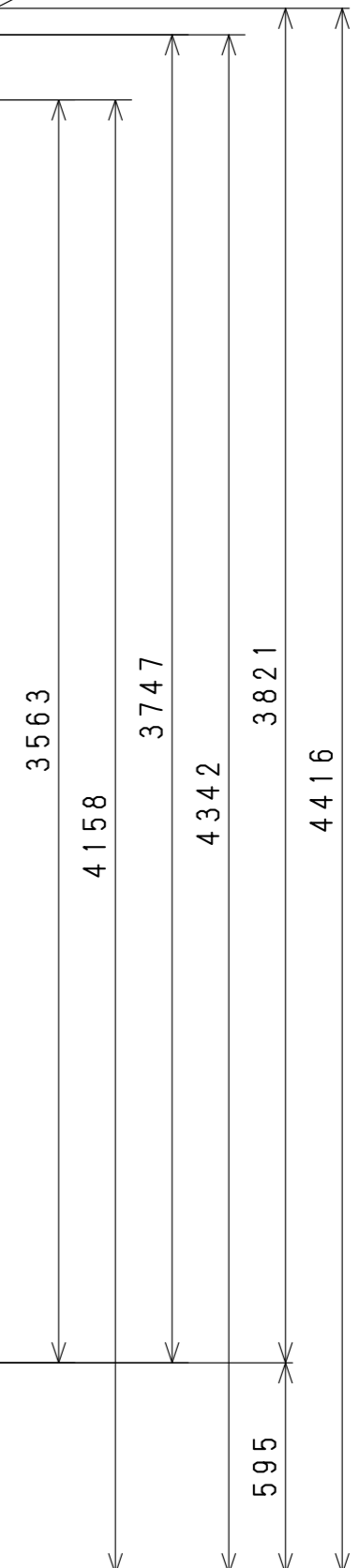

MG15HL-B
WORKING RANGE