



Standard Specifications

KJ125J-B

1st ed. 30-May-19

3rd ed. 05-Mar-21

Kawasaki Heavy Industries, Ltd.
Robot Business Division

Specification number : 90151-0270DEC

Robot specifications

1. Model	KJ125J-B															
2. Type	Articulated robot															
3. Degree of freedom	6 axes															
4. Max. payload	Wrist : 8 kg (at the tool mounting surface) Upper arm : 5 kg (including painting equipment in the pressurized chamber) Lower arm : 5 kg															
5. Max. reach	1,299 mm															
6. Position repeatability	±0.15 mm (wrist flange surface) conforms to ISO 9283															
7. Max. painting speed	1,500 mm/s (at the center of tool mounting surface)															
8. Axis specification	<table border="1"> <thead> <tr> <th>Operating axis</th> <th>Motion range</th> </tr> </thead> <tbody> <tr> <td>Arm rotation (JT1)</td> <td>±160°</td> </tr> <tr> <td>Arm out-in (JT2)</td> <td>+ 130° - - 80°</td> </tr> <tr> <td>Arm up-down (JT3)</td> <td>+ 90° - - 75°</td> </tr> <tr> <td>Wrist swivel (JT4)</td> <td>±720°</td> </tr> <tr> <td>Wrist bend (JT5)</td> <td>±720°</td> </tr> <tr> <td>Wrist twist (JT6)</td> <td>±410°</td> </tr> </tbody> </table>		Operating axis	Motion range	Arm rotation (JT1)	±160°	Arm out-in (JT2)	+ 130° - - 80°	Arm up-down (JT3)	+ 90° - - 75°	Wrist swivel (JT4)	±720°	Wrist bend (JT5)	±720°	Wrist twist (JT6)	±410°
Operating axis	Motion range															
Arm rotation (JT1)	±160°															
Arm out-in (JT2)	+ 130° - - 80°															
Arm up-down (JT3)	+ 90° - - 75°															
Wrist swivel (JT4)	±720°															
Wrist bend (JT5)	±720°															
Wrist twist (JT6)	±410°															
9. Load capacity of wrist	<table border="1"> <thead> <tr> <th></th> <th>Max. torque</th> <th>Moment of inertia*</th> </tr> </thead> <tbody> <tr> <td>JT4</td> <td>21.8 N·m</td> <td>0.90 kg·m²</td> </tr> <tr> <td>JT5</td> <td>17.0 N·m</td> <td>0.54 kg·m²</td> </tr> <tr> <td>JT6</td> <td>8.0 N·m</td> <td>0.12 kg·m²</td> </tr> </tbody> </table> <p>Note* Each value in this table shows allowable moment of inertia of JT4/JT5/JT6 when max. allowed torque is applied to each axis. If more detailed data is required for your application, please contact Kawasaki.</p>			Max. torque	Moment of inertia*	JT4	21.8 N·m	0.90 kg·m ²	JT5	17.0 N·m	0.54 kg·m ²	JT6	8.0 N·m	0.12 kg·m ²		
	Max. torque	Moment of inertia*														
JT4	21.8 N·m	0.90 kg·m ²														
JT5	17.0 N·m	0.54 kg·m ²														
JT6	8.0 N·m	0.12 kg·m ²														
10. Mass	190 kg (without options)															
11. Mounting	Floor or Wall mounting															
12. Installation Environment	Ambient Temperature : 0 - 40 °C															
	Relative Humidity : 35 - 85 % (with no dew condensation)															
13. Color	Munsell 10GY9/1 equivalent															
14. Explosion proof	Pressurized and intrinsically safe															
15. Air supply to the manipulator	Clean & dry air	0.5 Nm ³ /min, 0.4 - 0.7 MPa														
	Dew point	- 17 or less at atmospheric pressure														
	Solid material	0.01 μm or less														
	Oil content	Mist separation 99.9999% or more														
16. Options	Mechanical stopper	Adjustable stoppers JT1/JT2/JT3														
	Painting equipment	Solenoid valve for painting (up to 1 units can be equipped with)														

Consult Kawasaki about maintenance parts and spare parts.

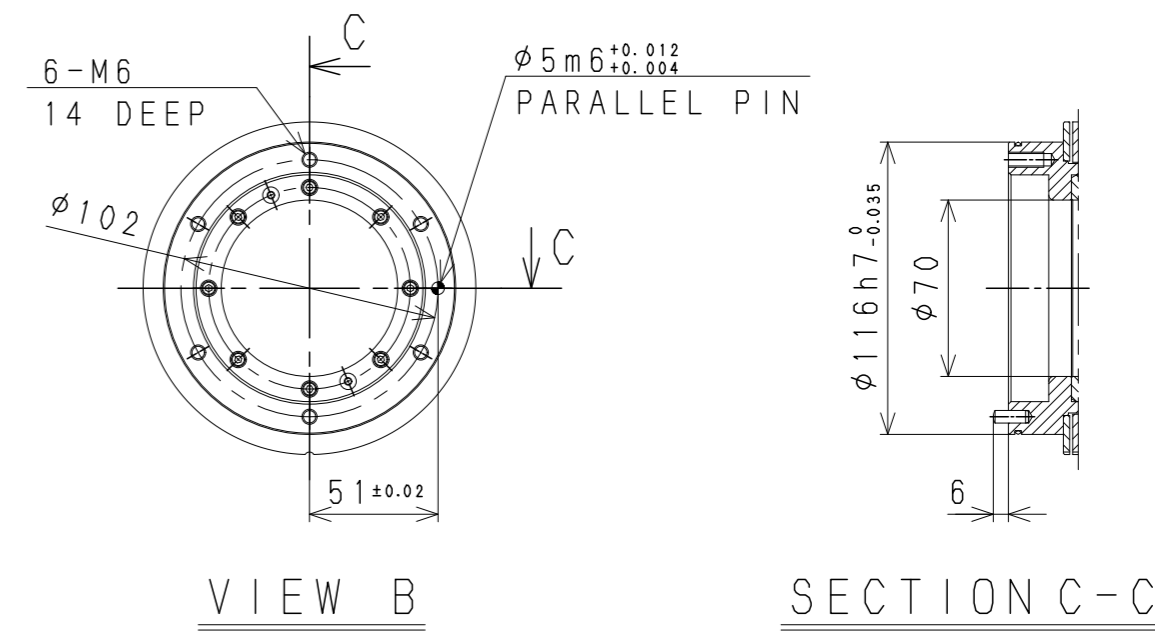
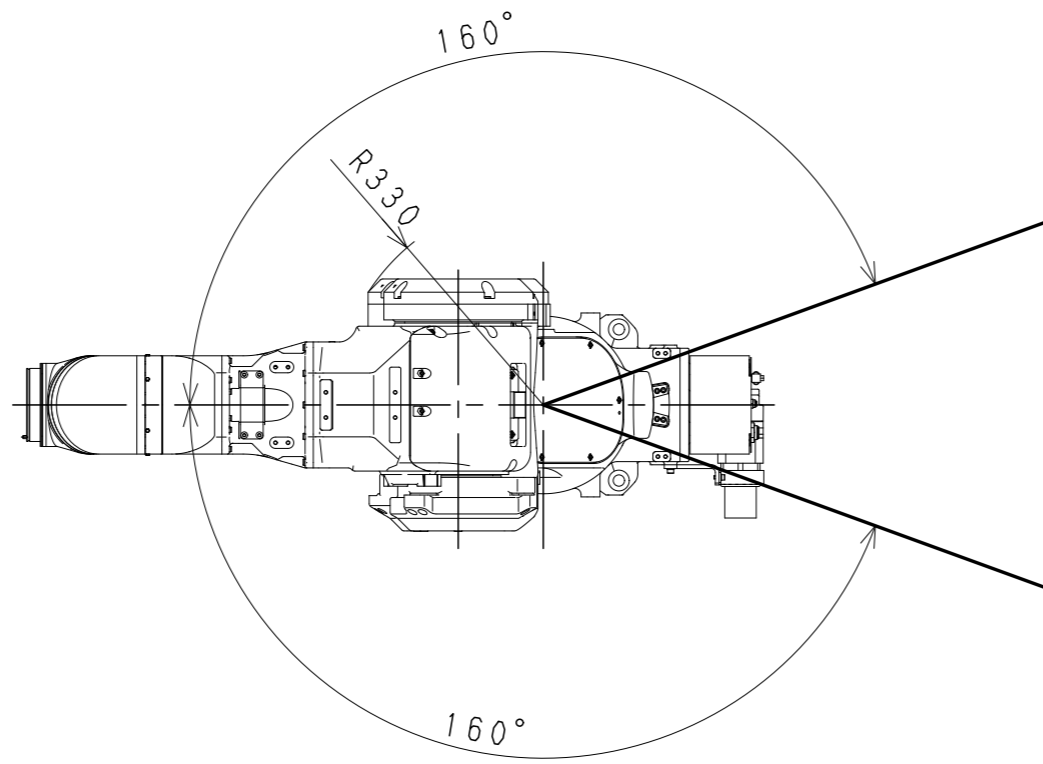

Working range based on point P

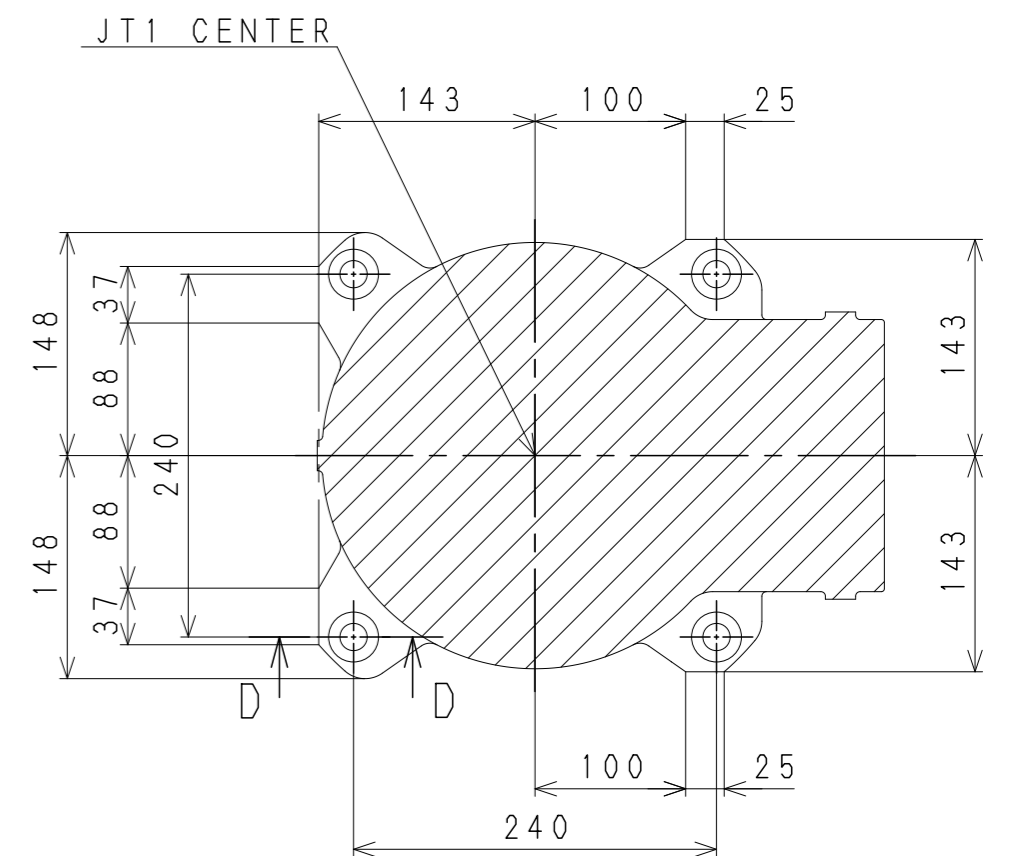
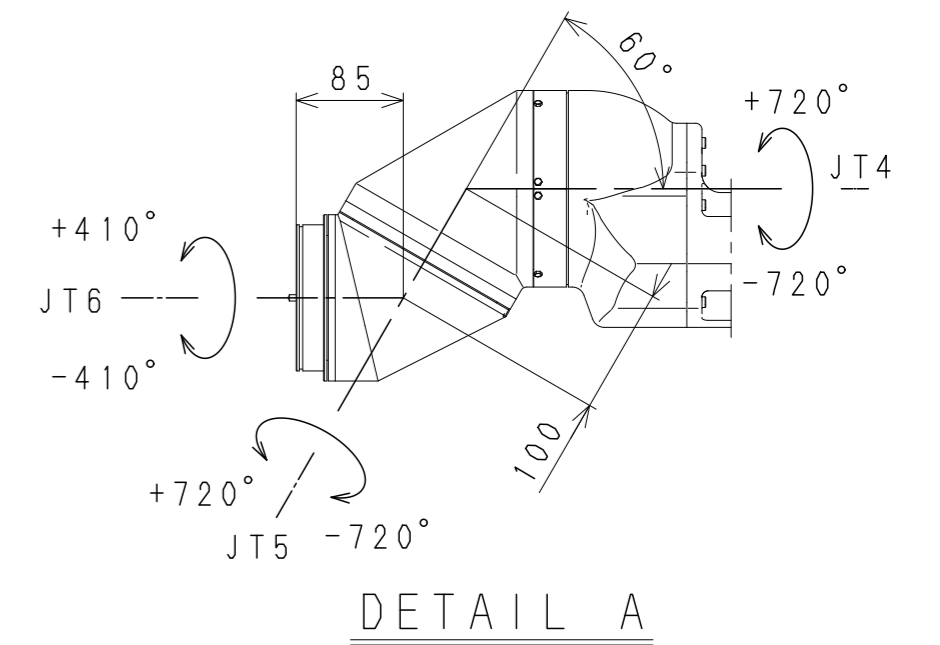
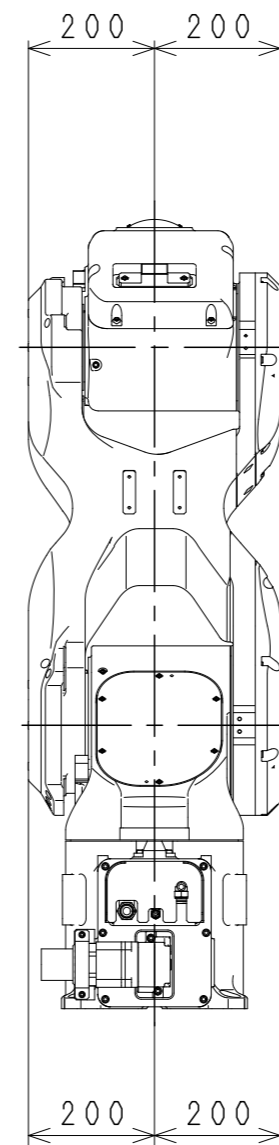
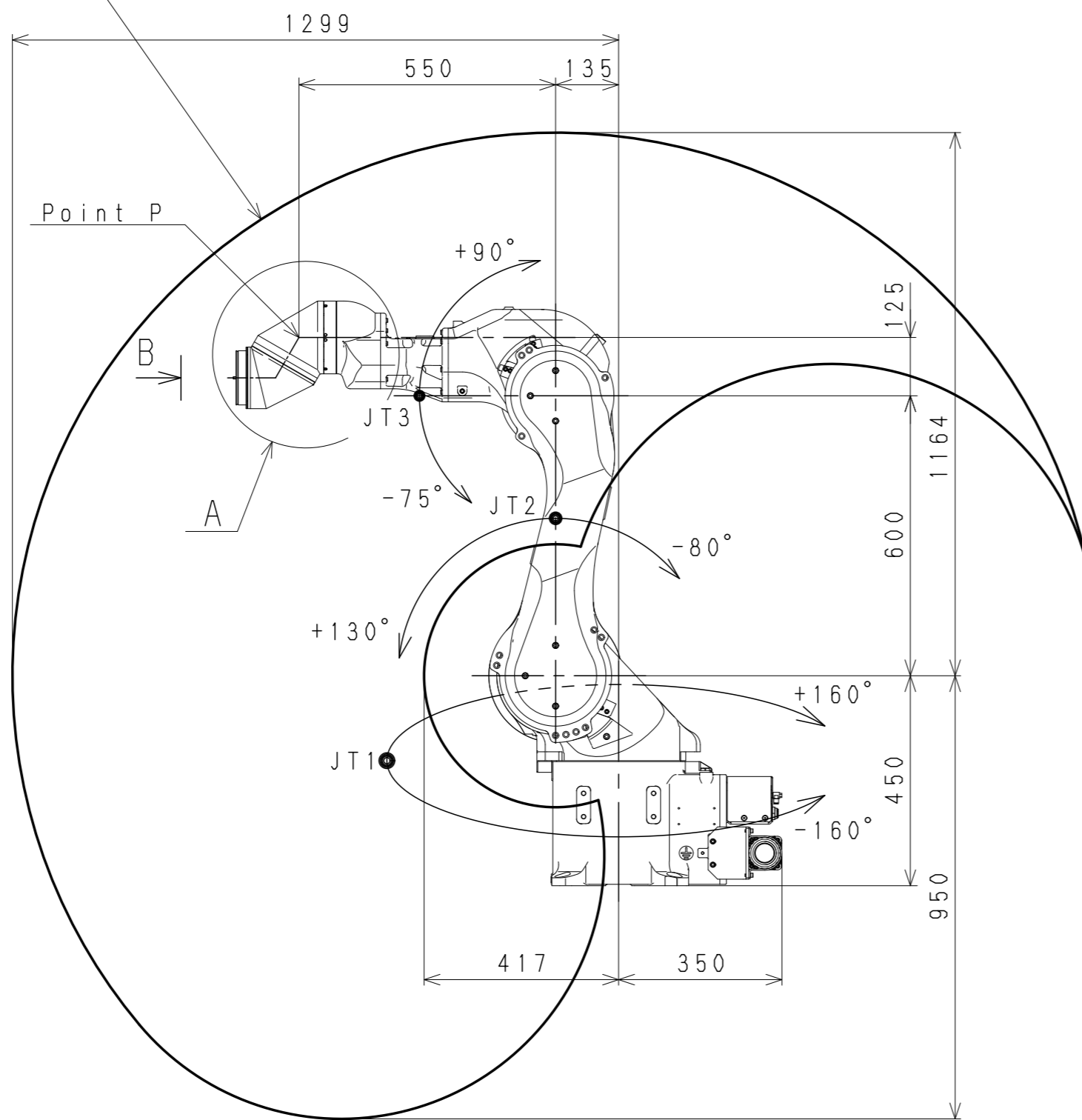
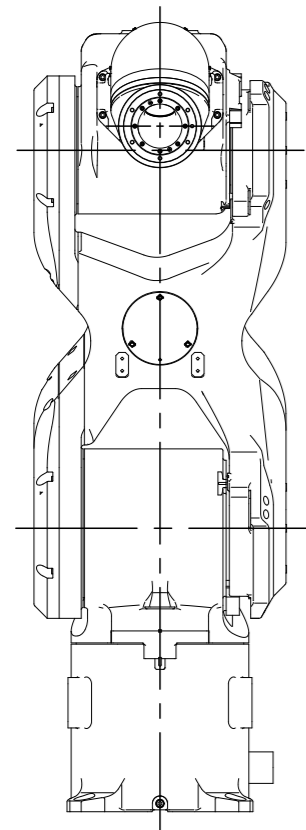

Base Installation Dimensions

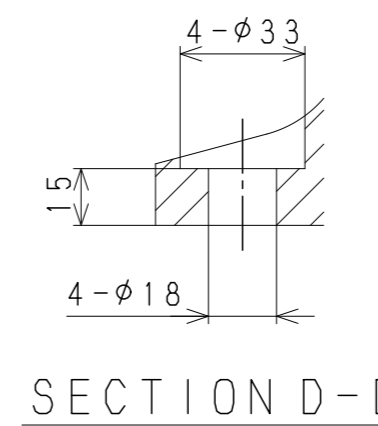

KJ125J-B
WORKING RANGE

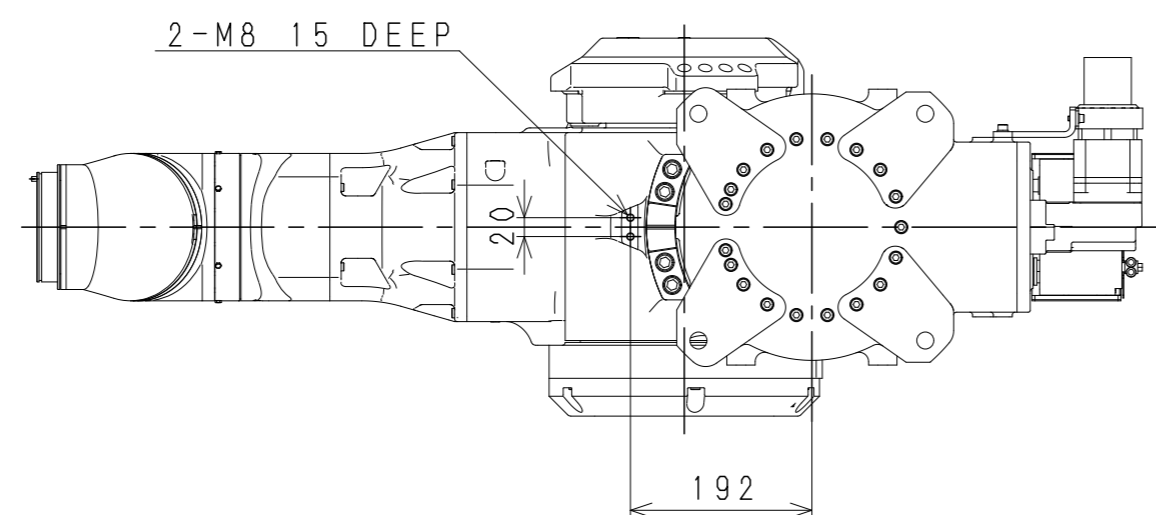
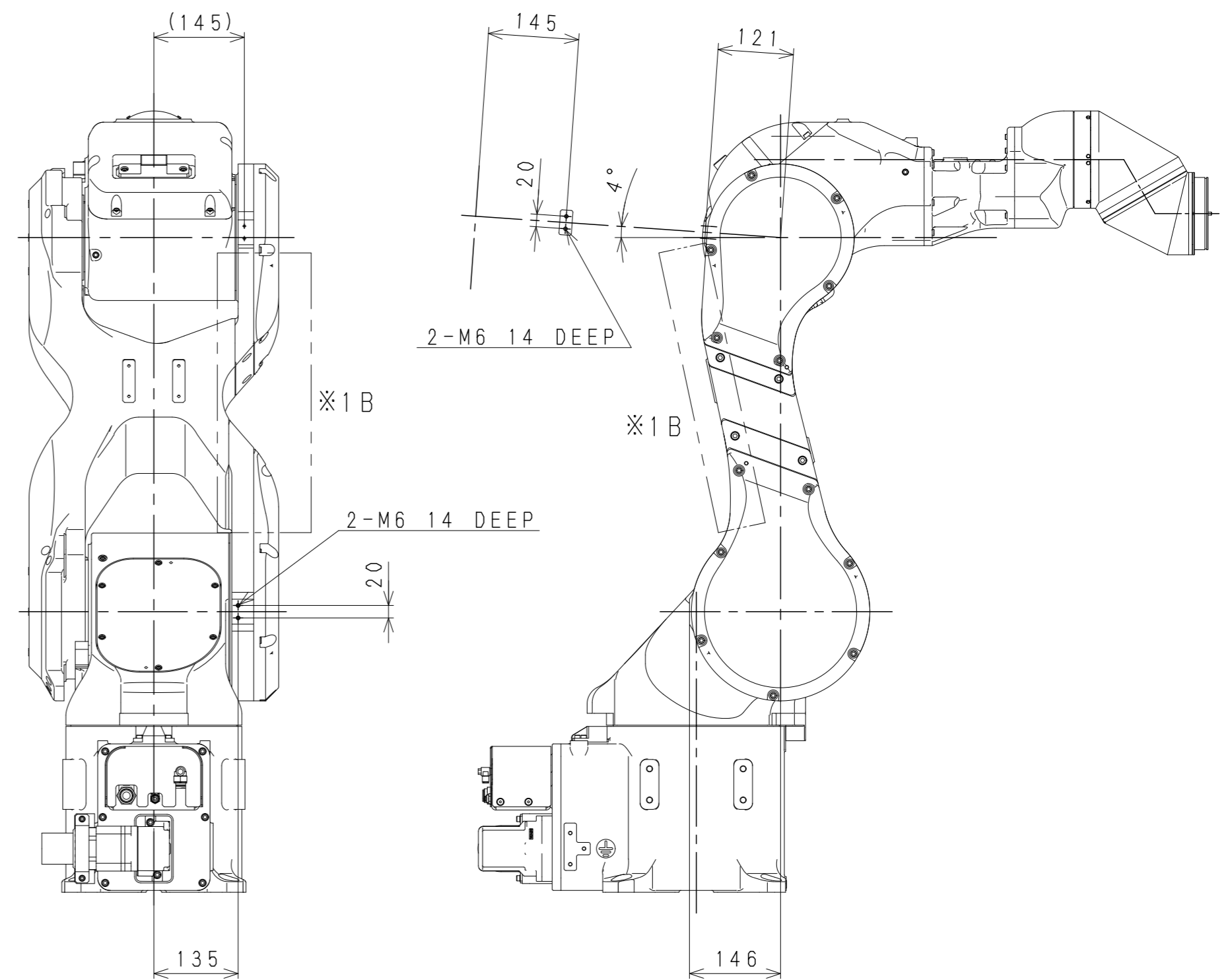
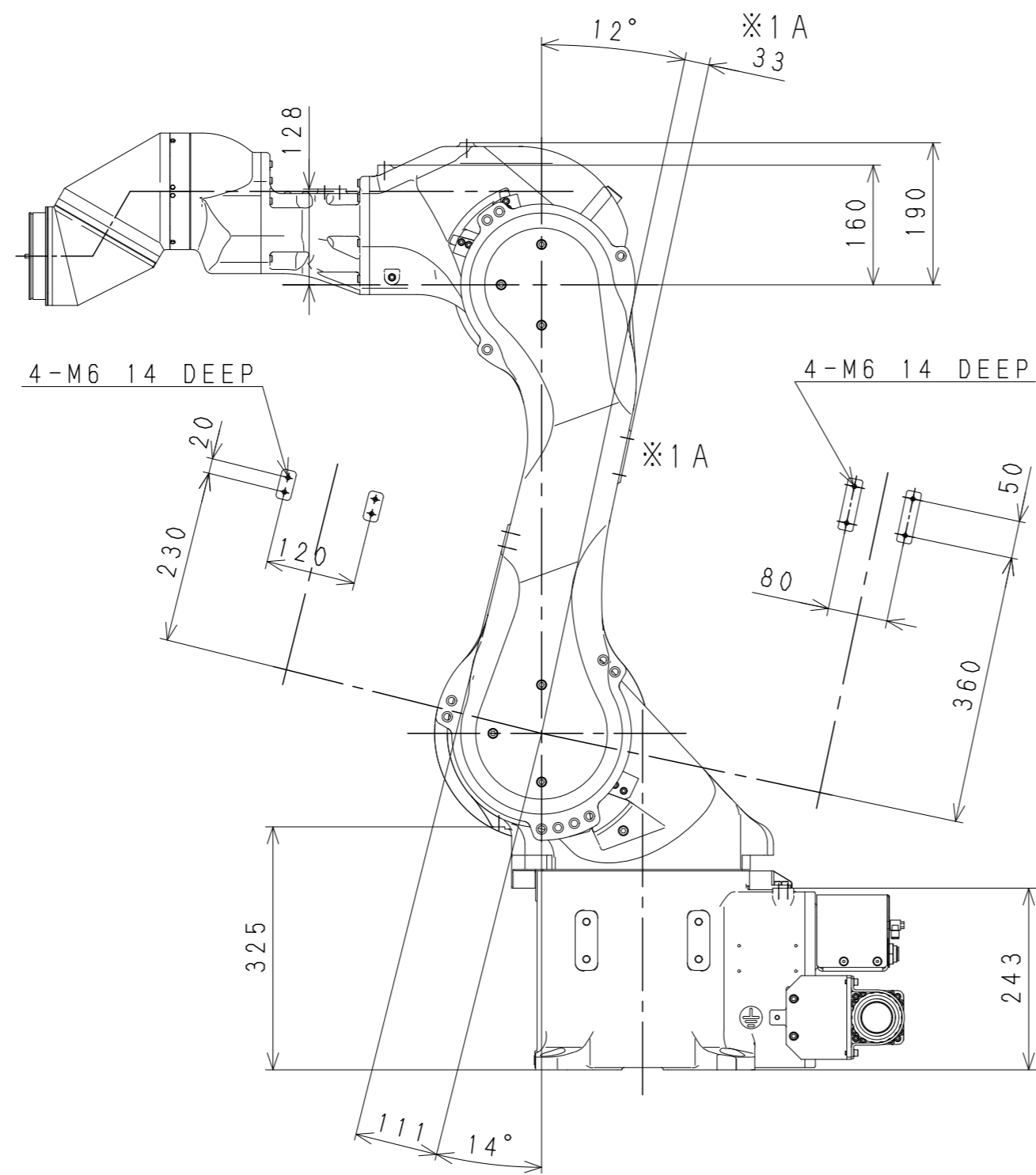
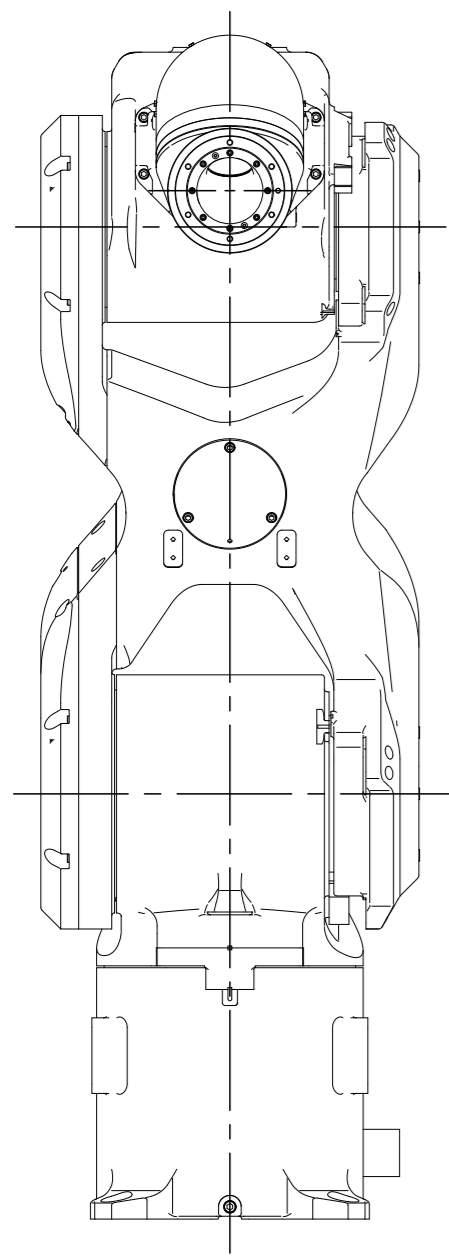
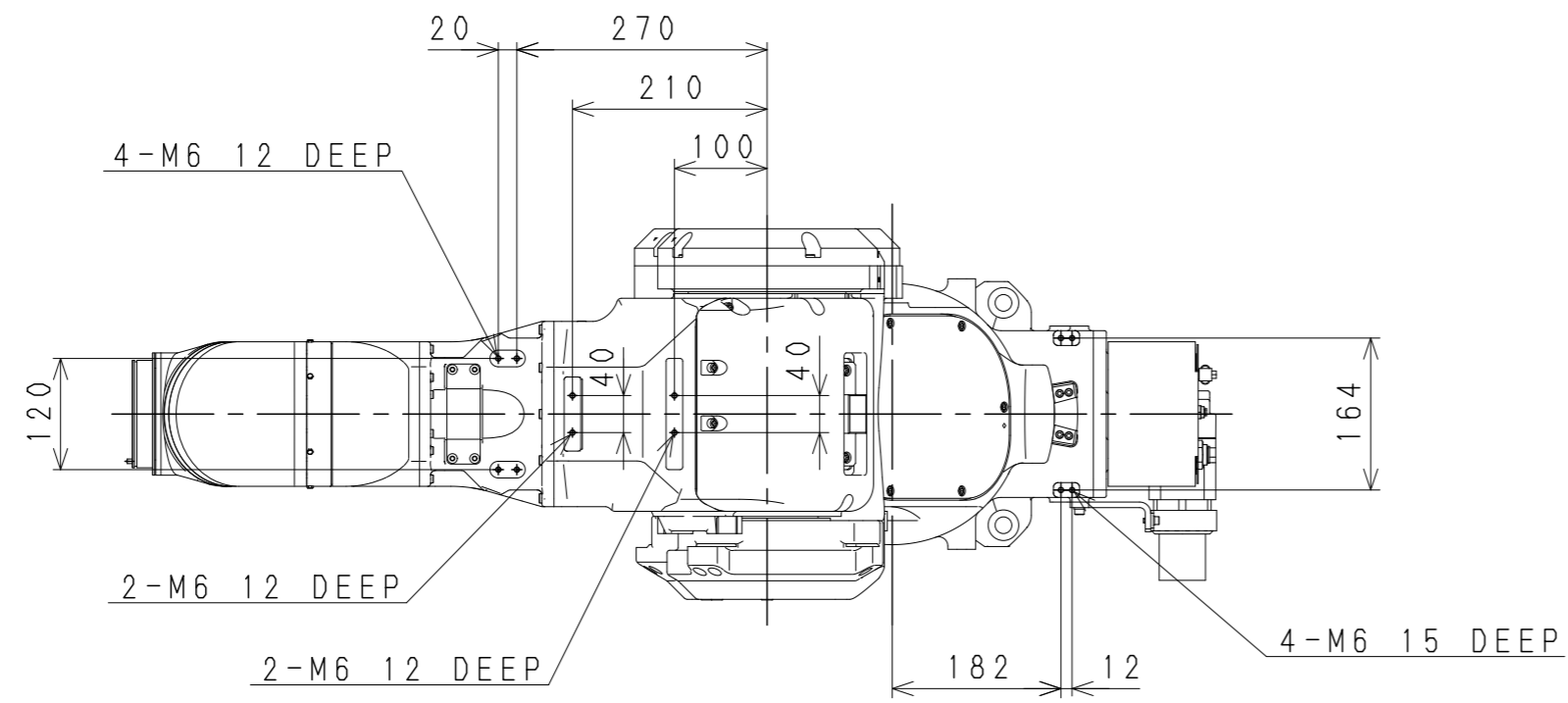

※1
 ※1 Bは部品の接合部であり、実機と上図の外形にズレが生じることがあります。
 ※1 Aに固定するブラケットが、※1 Bの近くに位置する場合は、ブラケットと
 ※1 Bの間に十分なクリアランスを設けてください。

Near by ※1B, there may be a gap between the actual shape
 and drawing shape.
 When you fix a bracket near ※1B, please provide enough
 clearance between the bracket and ※1B.

KJ125J-B
 SERVICE TAP LOCATION