



Standard Specifications

RS005L-A

1st ed. 17-Nov-16

2nd ed. 12-Oct-20

Kawasaki Heavy Industries, Ltd.
Robot Business Division

Specification number : 90151-0186DEB

Robot specifications

1. Model	RS005L-A																							
2. Type	Articulated robot																							
3. Degree of freedom	6 axes																							
4. Max. payload	5 kg																							
5. Max. reach	903 mm																							
6. Position repeatability	±0.03 mm (wrist flange surface) conforms to ISO 9283																							
7. Axis specification	<table border="1"> <thead> <tr> <th>Operating axis</th> <th>Motion range</th> <th>Max. speed</th> </tr> </thead> <tbody> <tr> <td>Arm rotation (JT1)</td> <td>±180 °</td> <td>300 °/s</td> </tr> <tr> <td>Arm out-in (JT2)</td> <td>+135 ° - -80 °</td> <td>300 °/s</td> </tr> <tr> <td>Arm up-down (JT3)</td> <td>+118 ° - -172 °</td> <td>300 °/s</td> </tr> <tr> <td>Wrist swivel (JT4)</td> <td>±360 °</td> <td>460 °/s</td> </tr> <tr> <td>Wrist bend (JT5)</td> <td>±145 °</td> <td>460 °/s</td> </tr> <tr> <td>Wrist twist (JT6)</td> <td>±360 °</td> <td>740 °/s</td> </tr> </tbody> </table>		Operating axis	Motion range	Max. speed	Arm rotation (JT1)	±180 °	300 °/s	Arm out-in (JT2)	+135 ° - -80 °	300 °/s	Arm up-down (JT3)	+118 ° - -172 °	300 °/s	Wrist swivel (JT4)	±360 °	460 °/s	Wrist bend (JT5)	±145 °	460 °/s	Wrist twist (JT6)	±360 °	740 °/s	
Operating axis	Motion range	Max. speed																						
Arm rotation (JT1)	±180 °	300 °/s																						
Arm out-in (JT2)	+135 ° - -80 °	300 °/s																						
Arm up-down (JT3)	+118 ° - -172 °	300 °/s																						
Wrist swivel (JT4)	±360 °	460 °/s																						
Wrist bend (JT5)	±145 °	460 °/s																						
Wrist twist (JT6)	±360 °	740 °/s																						
8. Load capacity of wrist	<table border="1"> <thead> <tr> <th></th> <th>Max. torque</th> <th>Moment of inertia*</th> </tr> </thead> <tbody> <tr> <td>JT4</td> <td>12.3 N·m</td> <td>0.4 kg·m²</td> </tr> <tr> <td>JT5</td> <td>12.3 N·m</td> <td>0.4 kg·m²</td> </tr> <tr> <td>JT6</td> <td>7.0 N·m</td> <td>0.12 kg·m²</td> </tr> </tbody> </table> <p>Note* Each value in this table shows allowable moment of inertia of JT4/JT5/JT6 when max. allowed torque is applied to each axis. If more detailed data is required for your application, please contact Kawasaki.</p>			Max. torque	Moment of inertia*	JT4	12.3 N·m	0.4 kg·m ²	JT5	12.3 N·m	0.4 kg·m ²	JT6	7.0 N·m	0.12 kg·m ²										
	Max. torque	Moment of inertia*																						
JT4	12.3 N·m	0.4 kg·m ²																						
JT5	12.3 N·m	0.4 kg·m ²																						
JT6	7.0 N·m	0.12 kg·m ²																						
9. Mass	37 kg (without options)																							
10. Mounting	Floor or Ceiling mounting																							
11. Installation environment	Ambient temperature: 0 - 45 °C Relative humidity: 35 - 85 % (with no dew condensation)																							
12. Color	Munsell 10GY9/1 equivalent																							
13. Degree of protection	Wrist: IP67 equivalent, Arm: IP65 equivalent																							
14. Built-in utilities	Pneumatic piping (φ6 × 2 lines)																							
15. Options	<table border="1"> <tbody> <tr> <td>Mounting</td> <td>Wall mounting</td> </tr> <tr> <td>Degree of protection</td> <td>Arm: IP67 equivalent</td> </tr> <tr> <td>Sensor harness</td> <td>12 circuits, wired inside robot arm</td> </tr> <tr> <td>Solenoid valve</td> <td>Double solenoid / Single solenoid valves (3 units max.)</td> </tr> <tr> <td>Air cleaning equipment</td> <td>Filter, Regulator, Mist separator</td> </tr> <tr> <td>Mechanical stopper</td> <td>Adjustable stopper JT1</td> </tr> <tr> <td>Color</td> <td></td> </tr> <tr> <td>Installation stand</td> <td>300 mm, 600 mm height</td> </tr> <tr> <td>Base plate</td> <td>400 mm × 400 mm</td> </tr> <tr> <td></td> <td></td> </tr> <tr> <td></td> <td></td> </tr> </tbody> </table>		Mounting	Wall mounting	Degree of protection	Arm: IP67 equivalent	Sensor harness	12 circuits, wired inside robot arm	Solenoid valve	Double solenoid / Single solenoid valves (3 units max.)	Air cleaning equipment	Filter, Regulator, Mist separator	Mechanical stopper	Adjustable stopper JT1	Color		Installation stand	300 mm, 600 mm height	Base plate	400 mm × 400 mm				
Mounting	Wall mounting																							
Degree of protection	Arm: IP67 equivalent																							
Sensor harness	12 circuits, wired inside robot arm																							
Solenoid valve	Double solenoid / Single solenoid valves (3 units max.)																							
Air cleaning equipment	Filter, Regulator, Mist separator																							
Mechanical stopper	Adjustable stopper JT1																							
Color																								
Installation stand	300 mm, 600 mm height																							
Base plate	400 mm × 400 mm																							

Consult Kawasaki about maintenance parts and spare parts.

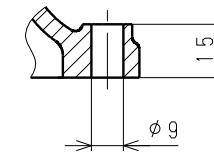
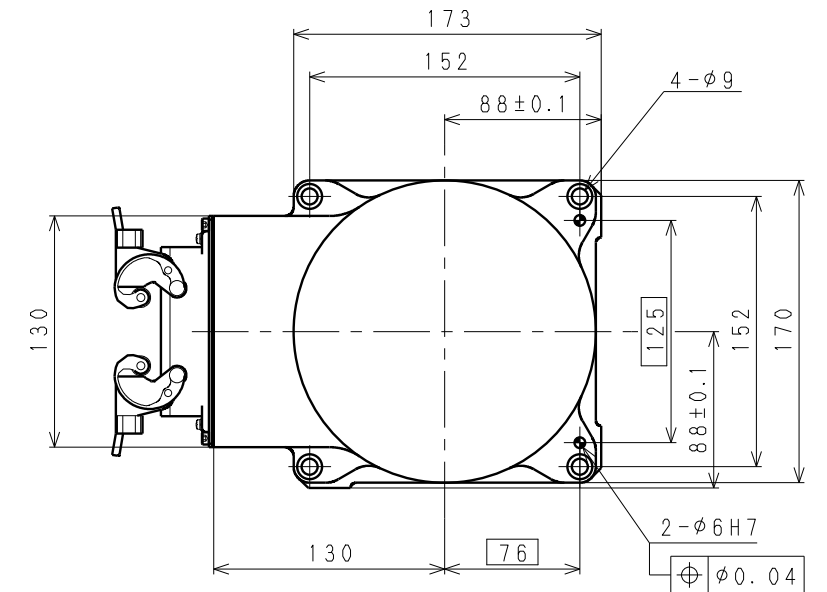
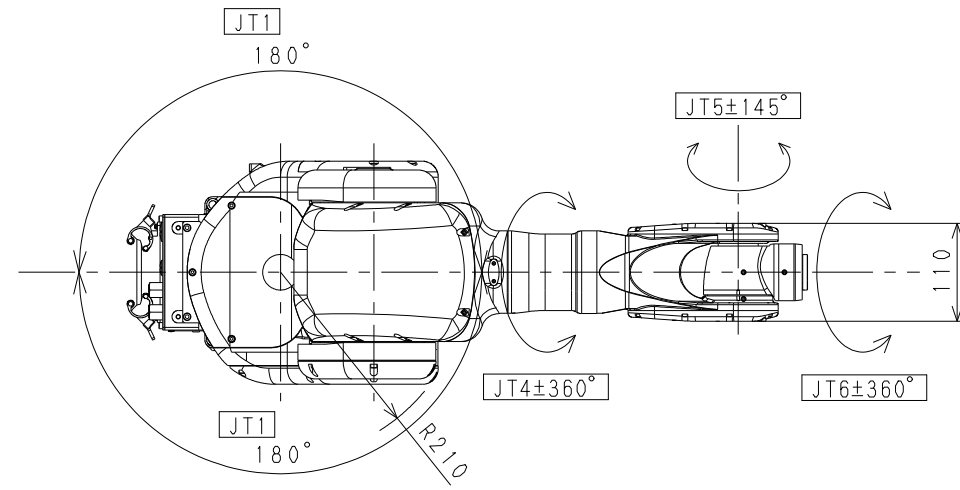

Installation Dimensions

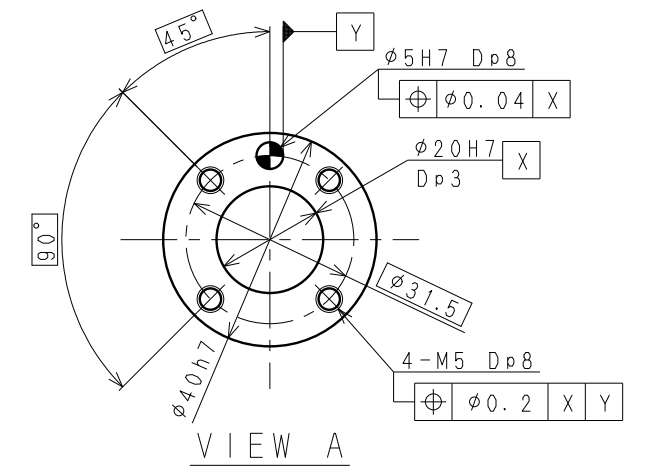
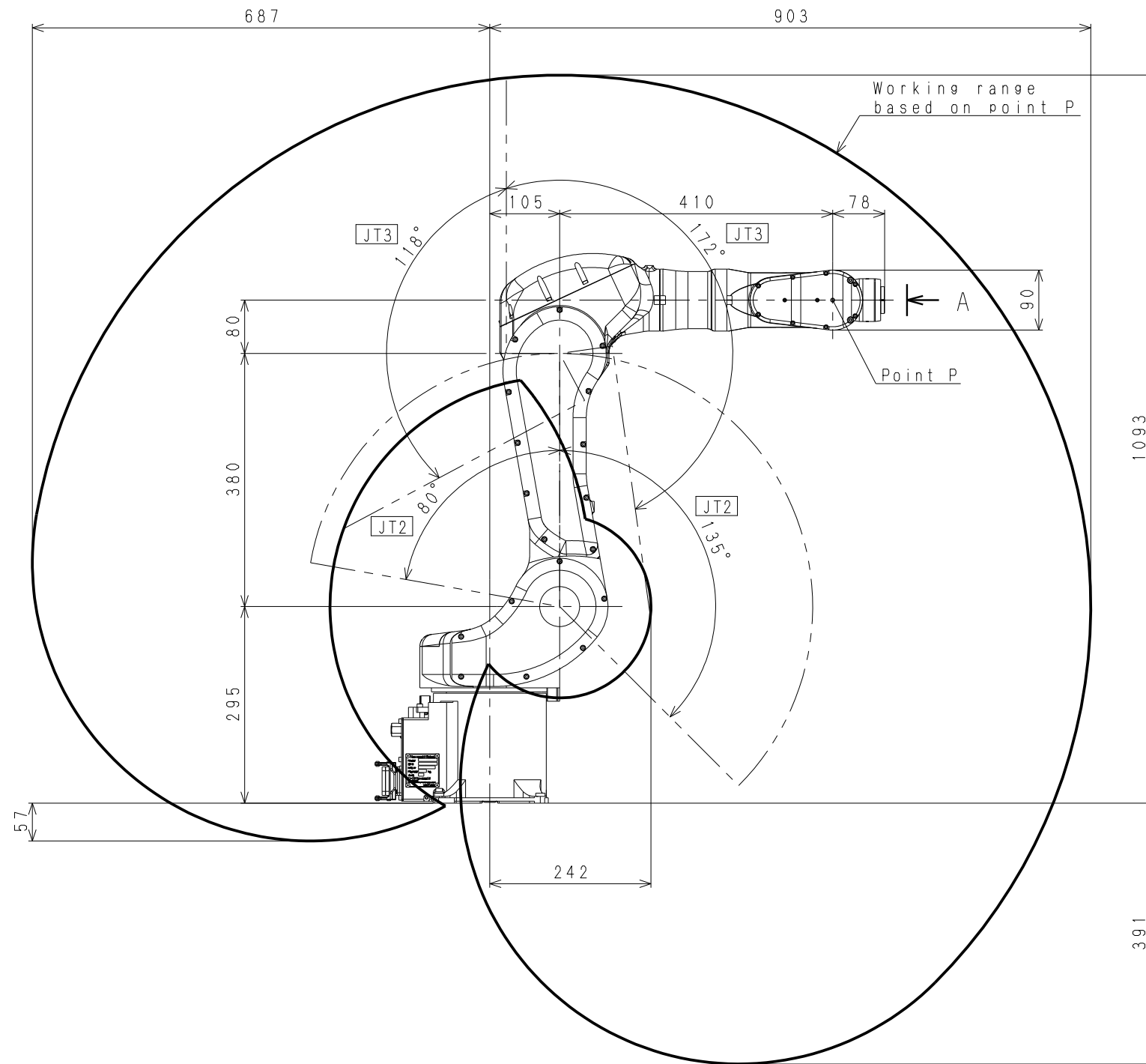
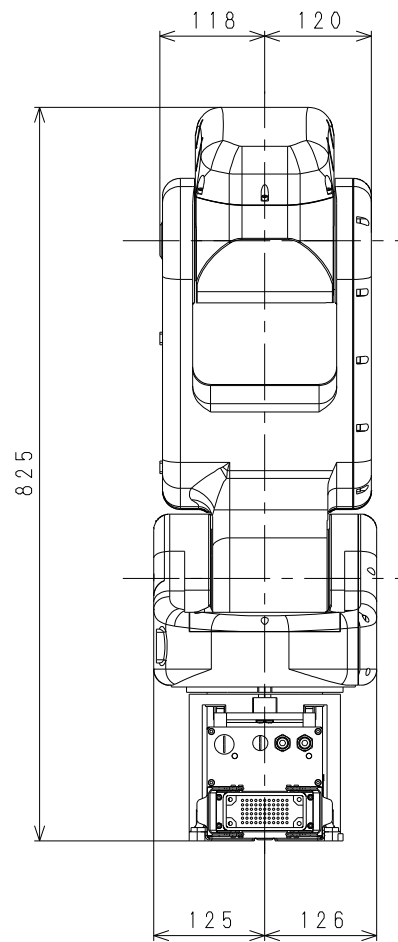

RS005L
WORKING RANGE