



Standard Specifications

MXP410X-A

1st ed. 03-Oct-22

2nd ed. 02-Feb-23

Kawasaki Heavy Industries, Ltd.
Robot Business Division

Specification number : 90151-0390DEB

Materials and specifications are subject to change without notice.

Robot specifications

1. Model	MXP410X-A																						
2. Type	Articulated robot																						
3. Degree of freedom	6 axes																						
4. Max. payload	410 kg																						
5. Max. reach	3,763 mm																						
6. Position repeatability	±0.12 mm (wrist flange surface) conforms to ISO 9283																						
7. Axis specification	<table border="1"> <thead> <tr> <th>Operating axis</th> <th>Motion range</th> <th>Max. speed^{*2}</th> </tr> </thead> <tbody> <tr> <td>Arm rotation (JT1)</td> <td>± 160 ° (±180 °)^{*1}</td> <td>82 ° /s</td> </tr> <tr> <td>Arm out-in (JT2)</td> <td>+ 90 ° - - 64 °</td> <td>70 ° /s</td> </tr> <tr> <td>Arm up-down (JT3)</td> <td>+ 40 ° - - 120 °</td> <td>70 ° /s</td> </tr> <tr> <td>Wrist swivel (JT4)</td> <td>±360 °</td> <td>110 ° /s</td> </tr> <tr> <td>Wrist bend (JT5)</td> <td>±122 °</td> <td>110 ° /s</td> </tr> <tr> <td>Wrist twist (JT6)</td> <td>±360 °</td> <td>160 ° /s</td> </tr> </tbody> </table> <p>Note^{*1} When using the operating range of +160° to +180° with JT1 or -160° to -180° with JT1, an optional mechanical stopper is required. In this case, the total maximum operating range is limited to 320°. If more detailed data is required for your application, please contact Kawasaki.</p> <p>Note^{*2} The values in the table are maximum values and vary depending on conditions such as load and motion range.</p>		Operating axis	Motion range	Max. speed ^{*2}	Arm rotation (JT1)	± 160 ° (±180 °) ^{*1}	82 ° /s	Arm out-in (JT2)	+ 90 ° - - 64 °	70 ° /s	Arm up-down (JT3)	+ 40 ° - - 120 °	70 ° /s	Wrist swivel (JT4)	±360 °	110 ° /s	Wrist bend (JT5)	±122 °	110 ° /s	Wrist twist (JT6)	±360 °	160 ° /s
Operating axis	Motion range	Max. speed ^{*2}																					
Arm rotation (JT1)	± 160 ° (±180 °) ^{*1}	82 ° /s																					
Arm out-in (JT2)	+ 90 ° - - 64 °	70 ° /s																					
Arm up-down (JT3)	+ 40 ° - - 120 °	70 ° /s																					
Wrist swivel (JT4)	±360 °	110 ° /s																					
Wrist bend (JT5)	±122 °	110 ° /s																					
Wrist twist (JT6)	±360 °	160 ° /s																					
8. Load capacity of wrist	<table border="1"> <thead> <tr> <th></th> <th>Max. torque</th> <th>Moment of inertia*</th> </tr> </thead> <tbody> <tr> <td>JT4</td> <td>3,000 N·m</td> <td>390 kg·m²</td> </tr> <tr> <td>JT5</td> <td>3,000 N·m</td> <td>390 kg·m²</td> </tr> <tr> <td>JT6</td> <td>1,900 N·m</td> <td>250 kg·m²</td> </tr> </tbody> </table> <p>Note* Each value in this table shows allowable moment of inertia of JT4/JT5/JT6 when max. allowed torque is applied to each axis. If more detailed data is required for your application, please contact Kawasaki.</p>			Max. torque	Moment of inertia*	JT4	3,000 N·m	390 kg·m ²	JT5	3,000 N·m	390 kg·m ²	JT6	1,900 N·m	250 kg·m ²									
	Max. torque	Moment of inertia*																					
JT4	3,000 N·m	390 kg·m ²																					
JT5	3,000 N·m	390 kg·m ²																					
JT6	1,900 N·m	250 kg·m ²																					
9. Mass	2,800 kg (without options)																						
10. Mounting	Floor mounting																						
11. Installation Environment	Ambient Temperature: 0 - 45 °C																						
	Relative Humidity: 35 - 85 % (with no dew condensation)																						
12. Color	Munsell 10GY9/1 equivalent																						
13. Degree of protection	Wrist: IP67 equivalent, Arm: IP54 equivalent																						
14. Options	Mechanical stopper	Adjustable stoppers JT1																					

Consult Kawasaki about maintenance parts and spare parts.

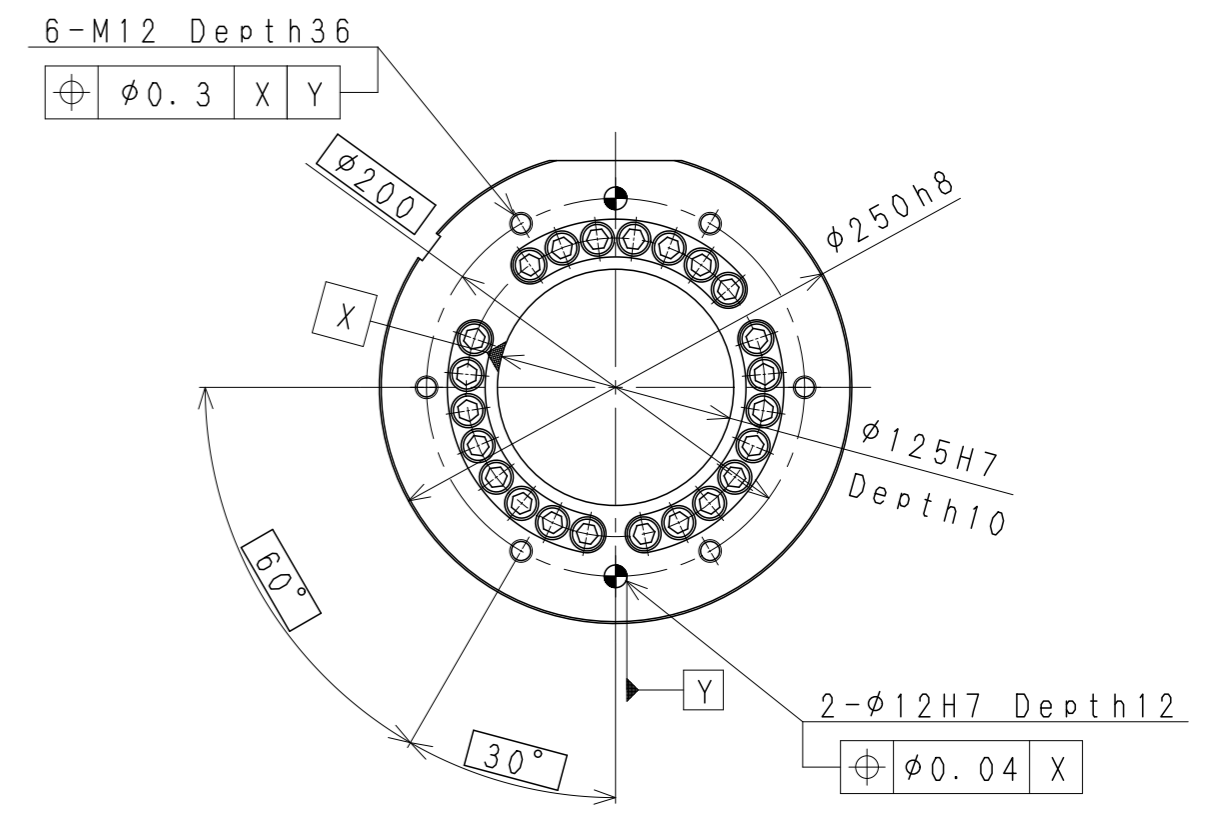
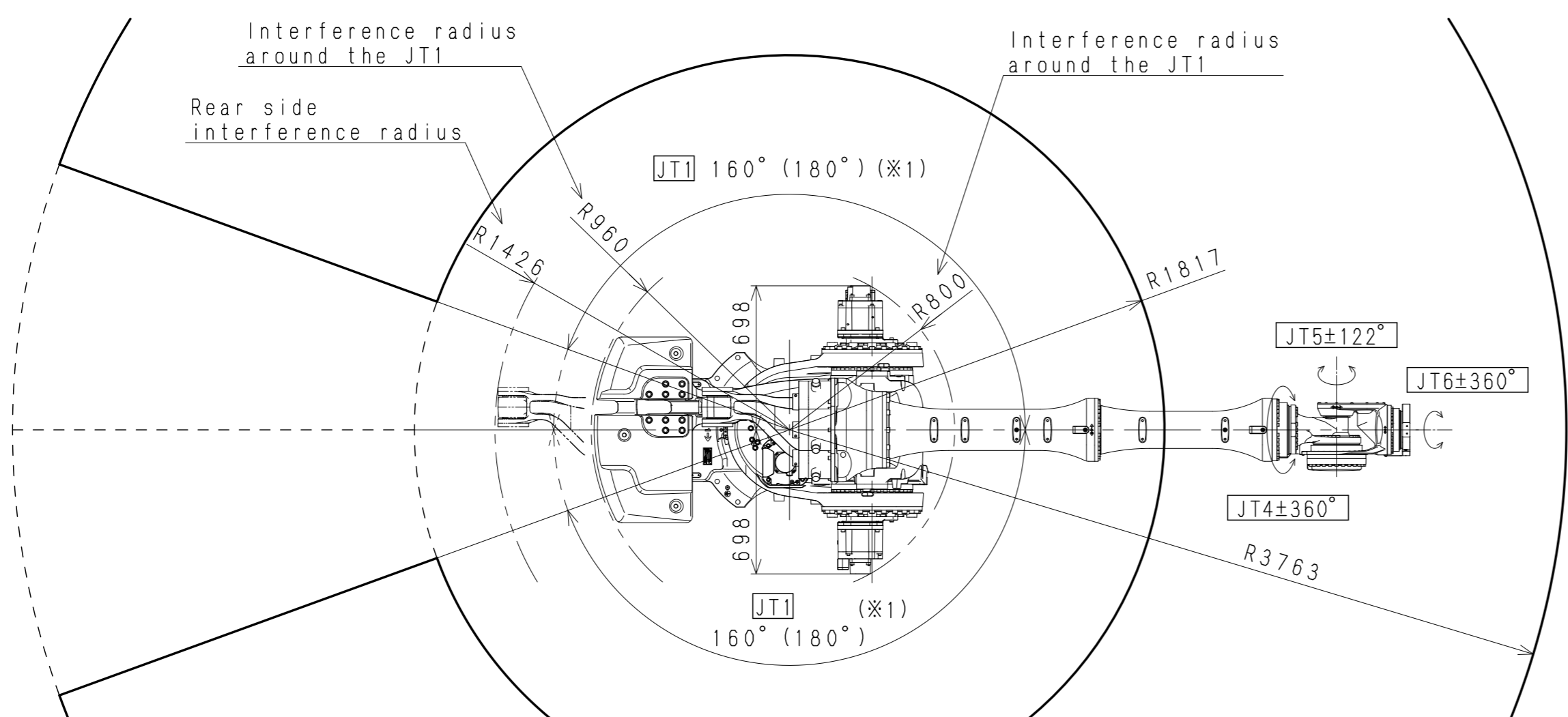

View A

※1.
JT1で+160°~+180°もしくは-160°~-180°の動作範囲を使用する際にはオプションメカストップが必要になります。また、その際には総動作範囲は最大320度に制限されます。

※1.
When using the operating range of +160° to +180° with JT1 or -160° to -180° with JT1, an optional mechanical stopper is required. In this case, the total maximum operating range is limited to 320°.

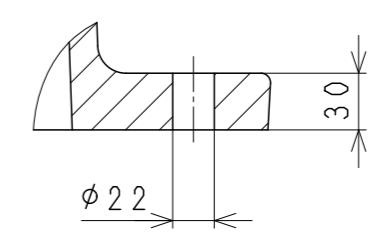
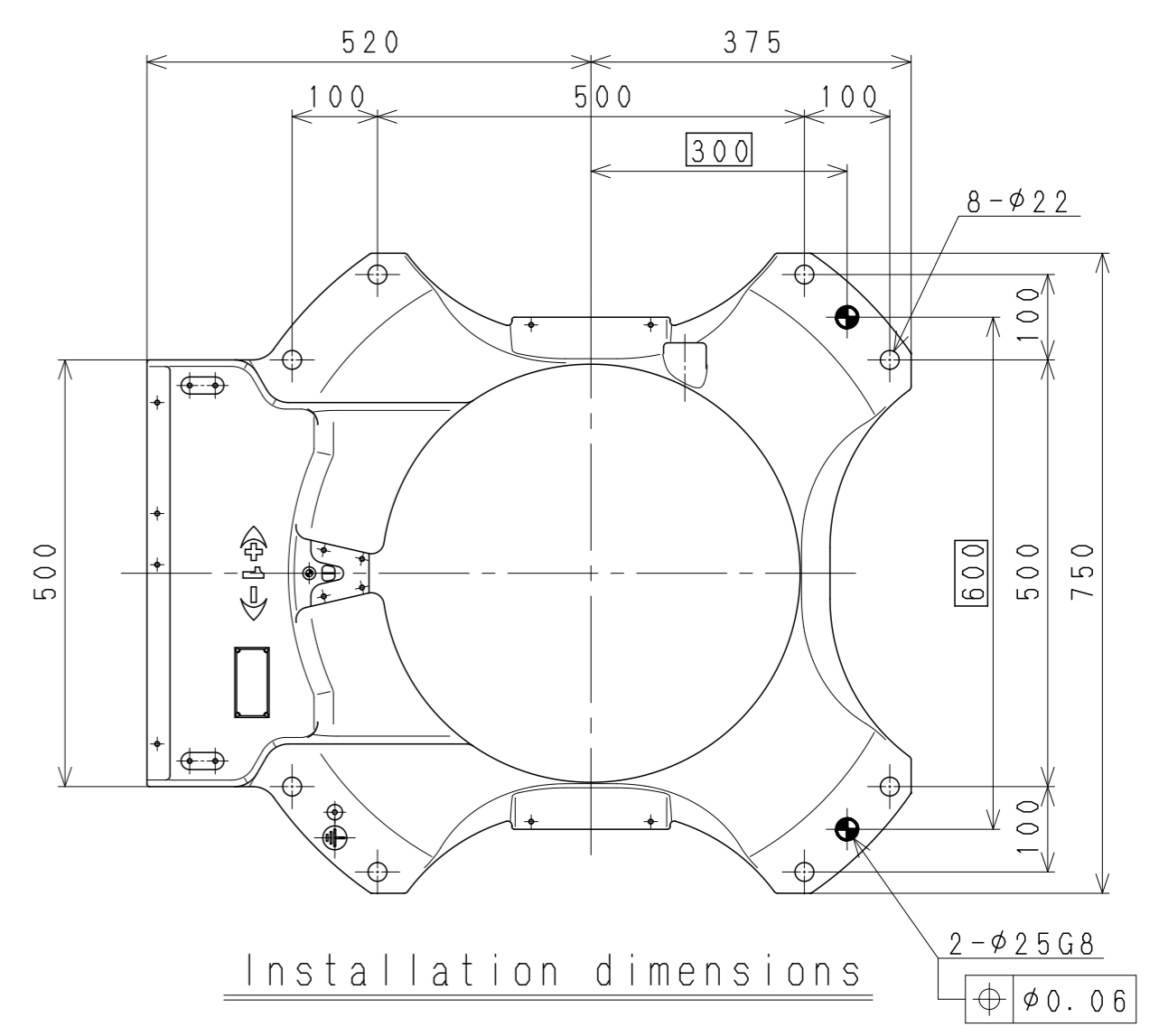
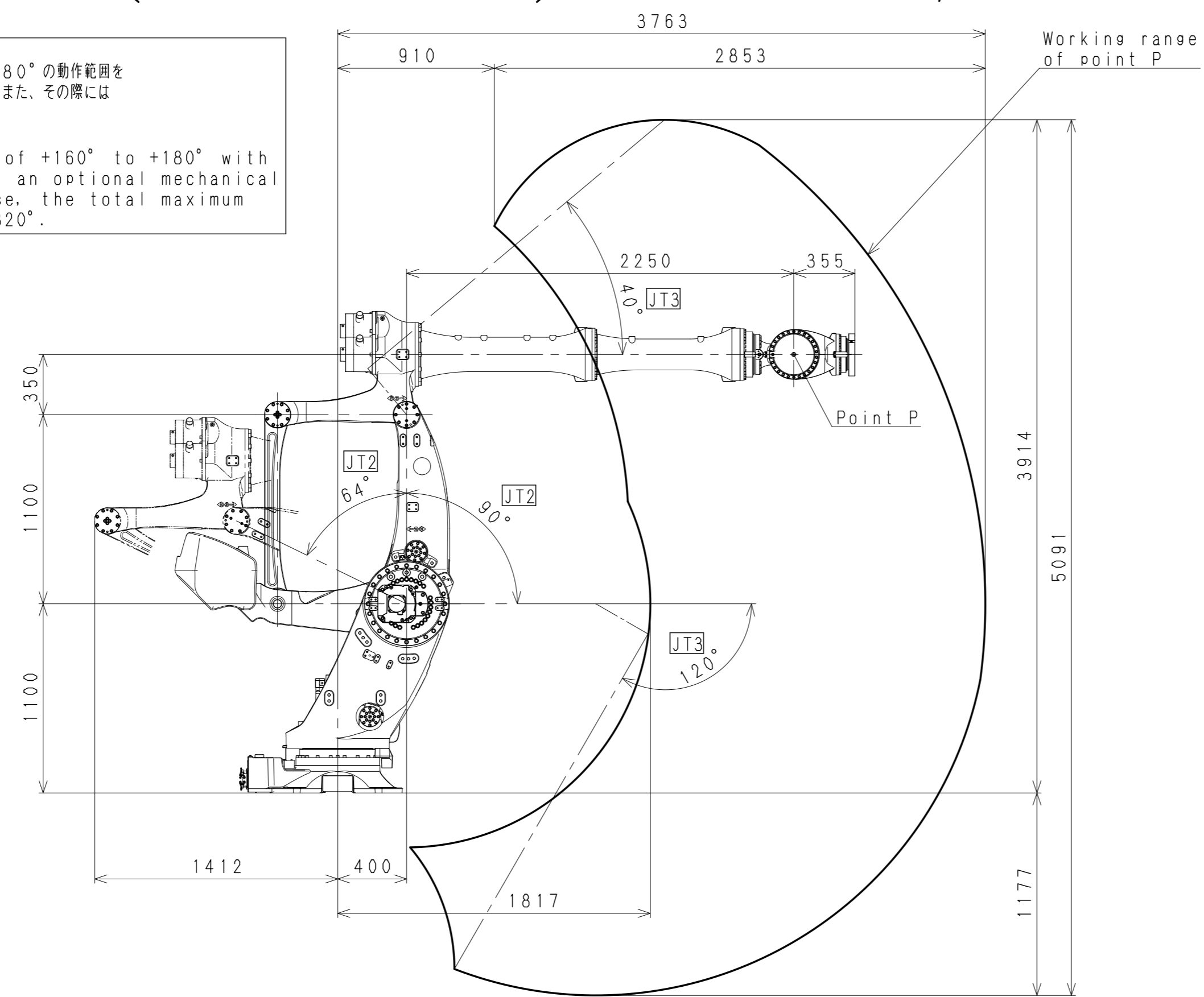

MXP410X
WORKING RANGE