



# 标准规格书

## BXP16N-A

创建A 2023年08月04日

川崎重工业株式会社  
机器人事业部

规格书编号： 90151-0370DCA

本规格书的刊载内容如出于完善的目的进行修订或更改，恕不另行通知。

## 机器人规格

1. 机械型号	BXP16N-A																						
2. 手臂形式	垂直多关节型																						
3. 自由度	6轴 (可选 7轴)																						
4. 最大可搬运质量	165kg																						
5. 最大覆盖范围	2,325mm																						
6. 位置重复精度	±0.06mm (手腕法兰面) 符合ISO9283																						
7. 构成轴规格	<table border="1"> <thead> <tr> <th>动作轴</th> <th>动作范围</th> <th>最大速度</th> </tr> </thead> <tbody> <tr> <td>手臂旋转 (JT1)</td> <td>±160°</td> <td>140°/s</td> </tr> <tr> <td>手臂前后 (JT2)</td> <td>+76°至-60°</td> <td>130°/s</td> </tr> <tr> <td>手臂上下 (JT3)</td> <td>+90°至-75°</td> <td>135°/s</td> </tr> <tr> <td>手腕旋转 (JT4)</td> <td>±210°</td> <td>190°/s</td> </tr> <tr> <td>手腕弯曲 (JT5)</td> <td>±125°</td> <td>180°/s</td> </tr> <tr> <td>手腕扭转 (JT6)</td> <td>±210°</td> <td>300°/s</td> </tr> </tbody> </table>		动作轴	动作范围	最大速度	手臂旋转 (JT1)	±160°	140°/s	手臂前后 (JT2)	+76°至-60°	130°/s	手臂上下 (JT3)	+90°至-75°	135°/s	手腕旋转 (JT4)	±210°	190°/s	手腕弯曲 (JT5)	±125°	180°/s	手腕扭转 (JT6)	±210°	300°/s
动作轴	动作范围	最大速度																					
手臂旋转 (JT1)	±160°	140°/s																					
手臂前后 (JT2)	+76°至-60°	130°/s																					
手臂上下 (JT3)	+90°至-75°	135°/s																					
手腕旋转 (JT4)	±210°	190°/s																					
手腕弯曲 (JT5)	±125°	180°/s																					
手腕扭转 (JT6)	±210°	300°/s																					
8. 手腕轴允许负载	<table border="1"> <thead> <tr> <th></th> <th>最大负载扭矩</th> <th>负载惯性矩<sup>*</sup></th> </tr> </thead> <tbody> <tr> <td>JT4</td> <td>940N·m</td> <td>105kg·m<sup>2</sup></td> </tr> <tr> <td>JT5</td> <td>940N·m</td> <td>105kg·m<sup>2</sup></td> </tr> <tr> <td>JT6</td> <td>510N·m</td> <td>50kg·m<sup>2</sup></td> </tr> </tbody> </table> <p>注<sup>*</sup> 此表中的值表示将允许的最大扭矩施加到手腕各轴时允许的负载惯性矩。 有关其他详细信息, 请另行咨询本公司。</p>			最大负载扭矩	负载惯性矩 <sup>*</sup>	JT4	940N·m	105kg·m <sup>2</sup>	JT5	940N·m	105kg·m <sup>2</sup>	JT6	510N·m	50kg·m <sup>2</sup>									
	最大负载扭矩	负载惯性矩 <sup>*</sup>																					
JT4	940N·m	105kg·m <sup>2</sup>																					
JT5	940N·m	105kg·m <sup>2</sup>																					
JT6	510N·m	50kg·m <sup>2</sup>																					
9. 质量	855kg (不包括选购件)																						
10. 安装方法	落地式																						
11. 安装环境	环境温度: 0至45 相对湿度: 35至85% (无结露)																						
12. 涂装颜色	相当于孟塞尔 10GY9/1																						
13. 防护等级	手腕部: IP67相当 基轴部: IP54相当																						
14. 配套	工具-手腕法兰之间的电缆长度为1.5m 如需更改标准配套规格, 请另行咨询。																						
15. 选购件	<table border="1"> <tbody> <tr> <td>机械挡块</td> <td>可变挡块: JT1/JT2/JT3</td> </tr> <tr> <td>适配器支架</td> <td>工具-手腕法兰之间</td> </tr> <tr> <td></td> <td></td> </tr> <tr> <td></td> <td></td> </tr> <tr> <td></td> <td></td> </tr> <tr> <td></td> <td></td> </tr> <tr> <td></td> <td></td> </tr> <tr> <td></td> <td></td> </tr> <tr> <td></td> <td></td> </tr> </tbody> </table>		机械挡块	可变挡块: JT1/JT2/JT3	适配器支架	工具-手腕法兰之间																	
机械挡块	可变挡块: JT1/JT2/JT3																						
适配器支架	工具-手腕法兰之间																						

有关维护零件和备件, 请另行咨询。

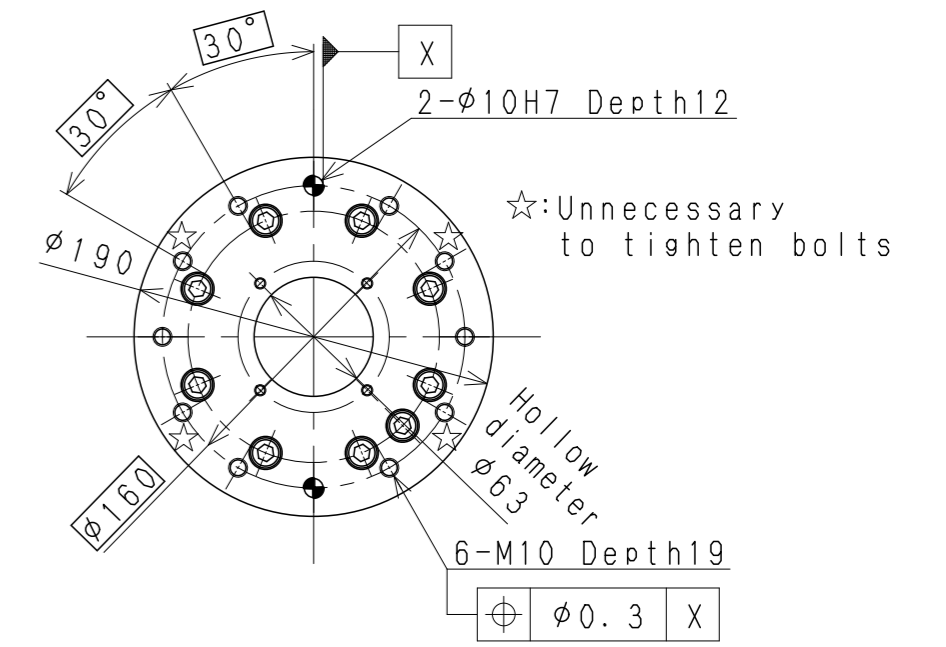
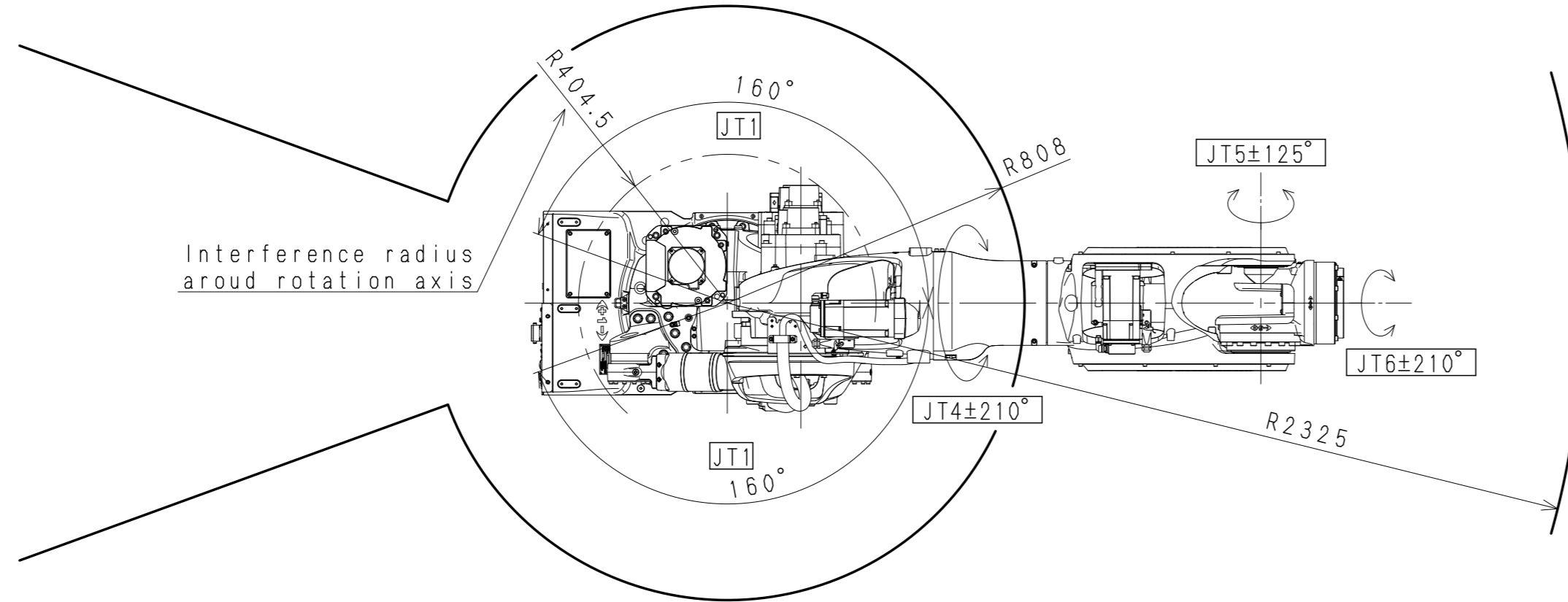

STANDARD FLANGE

※ Dimension:225

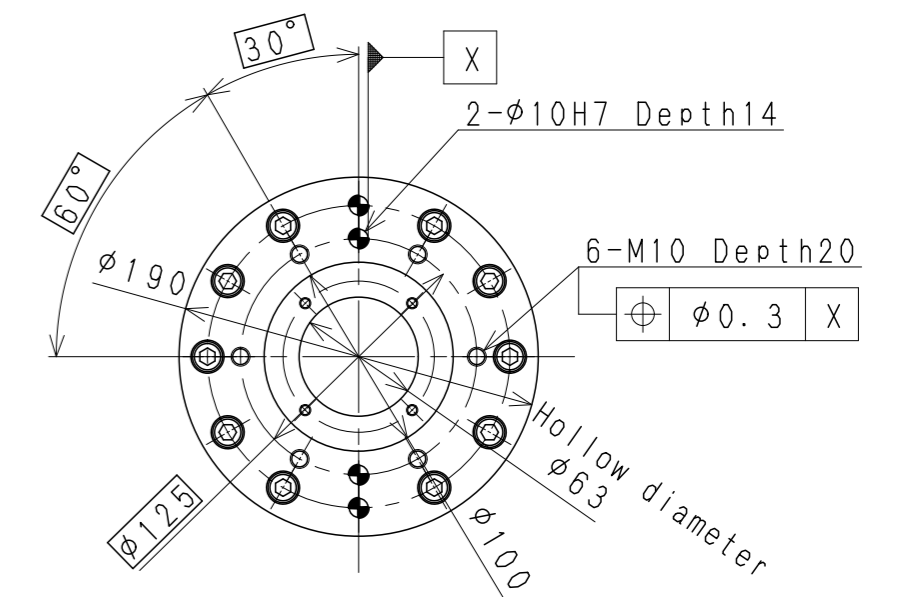

OPTION FLANGE

※ Dimension:245

View A

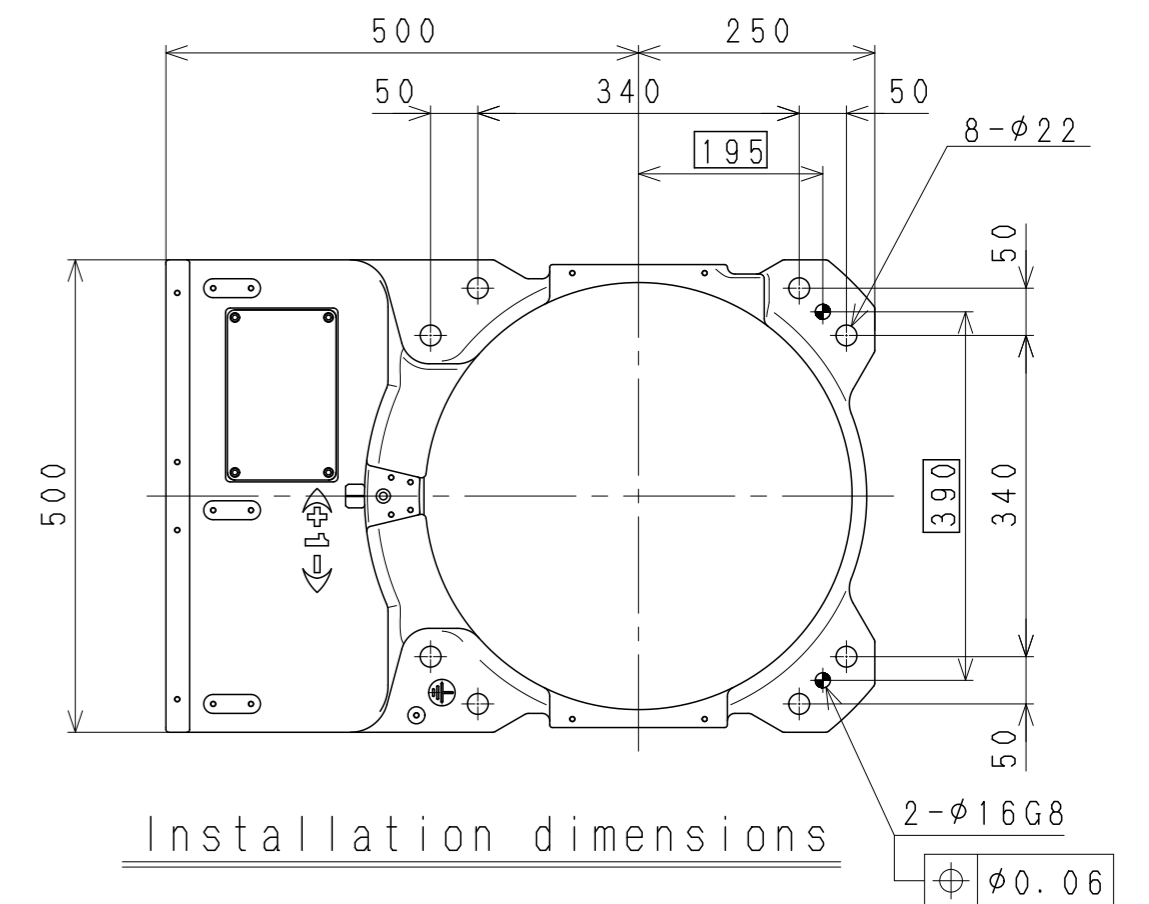
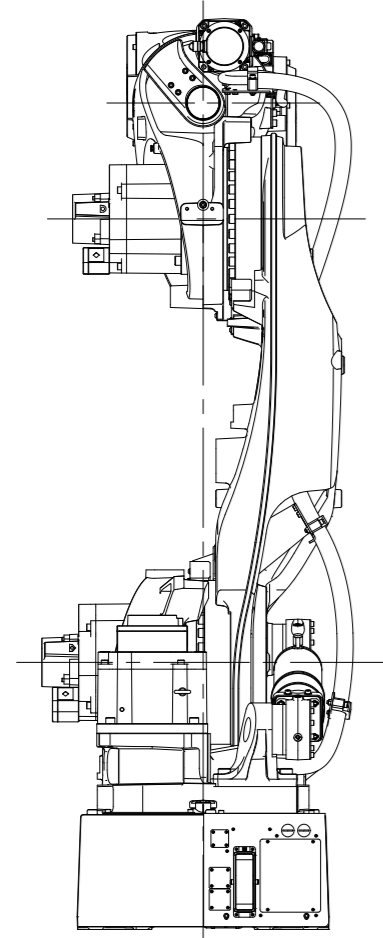
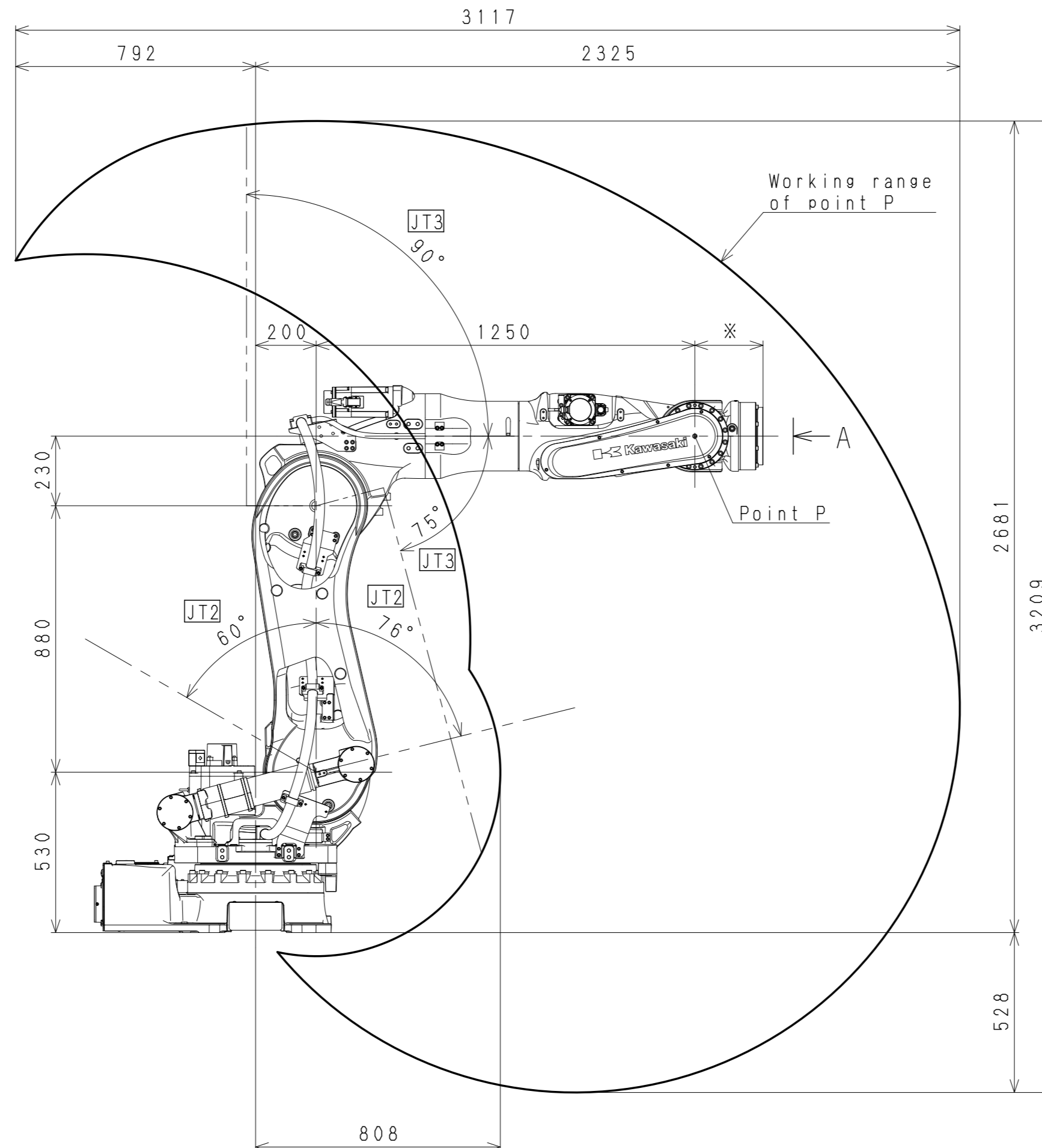

Installation dimensions

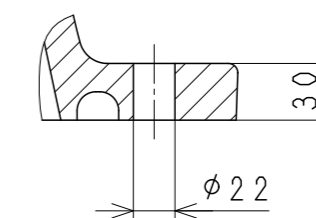

BXP165N  
WORKING RANGE