

CL Series Collaborative Robots Quick Start Guide

Edition: V1.0/ 05.2023
Document No.: 0001
Language: English

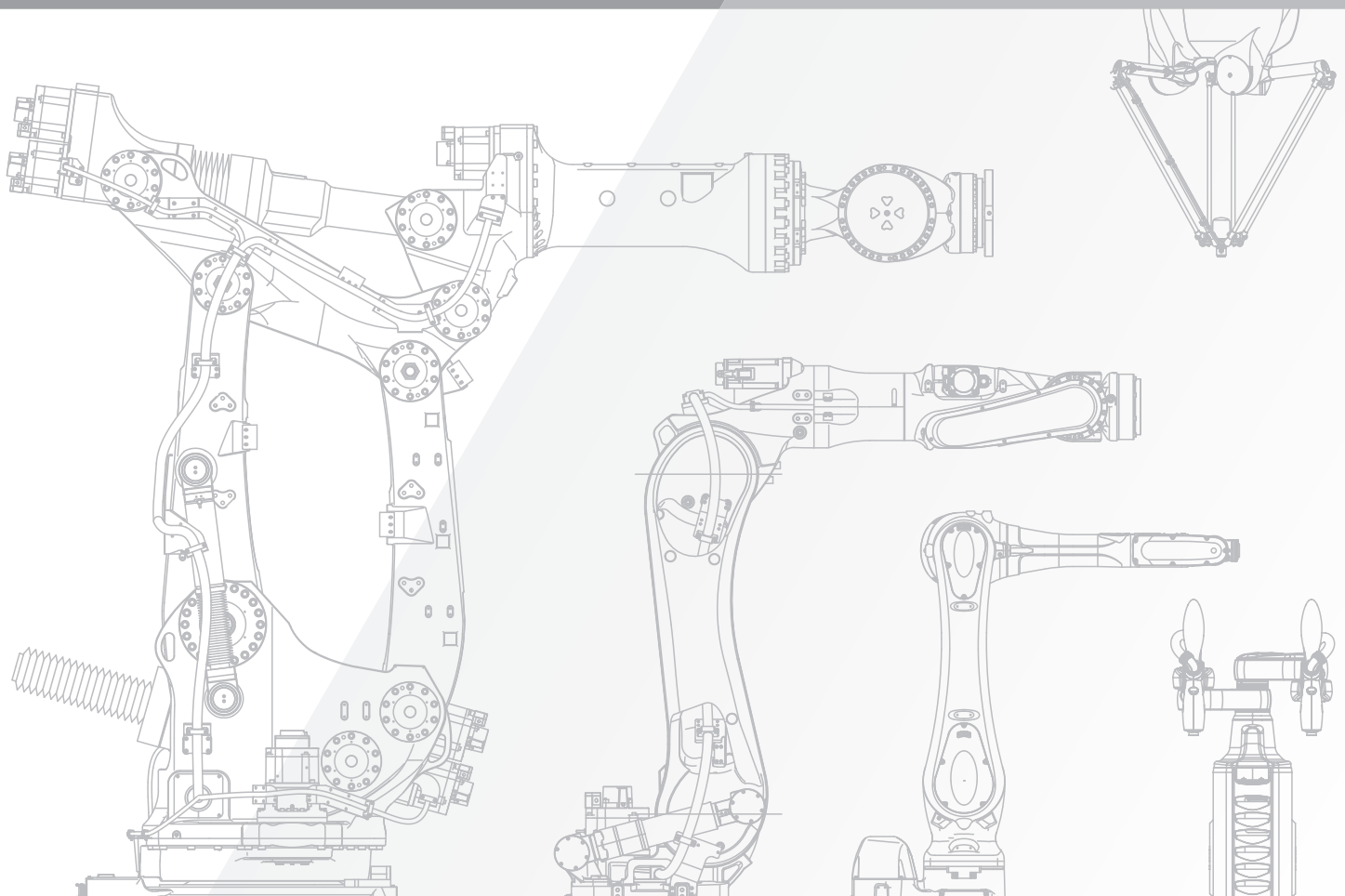

Copyright Notice

The Quick Start Guide will be checked and revised periodically, and the updated content will appear on the latest version.

The product information and related sources mentioned in this manual are for reference only and the information in this manual is subject to change without notice and be regarded as a commitment by Kawasaki Robotics GmbH.

Kawasaki Robotics GmbH takes no responsibility for any errors or omissions in this document or no responsibility for incidental or consequential damages arising from use of this manual and products described herein.

All rights reserved. No part of this publication may be reproduced or retransmitted in any form or by any means without the prior written consent of Kawasaki Robotics GmbH.

Table of Content

01	About this Document	1
1.1	How to use the Quick Start Guide	1
1.2	Related Documents	1
1.3	Robot Models	1
1.4	Technical Support	1
1.5	Contact Information	2
1.6	General Instructions	2
02	Inside The Box	3
03	Installation	4
3.1	Installation Flow Chart	4
3.2	Unpacking	5
3.3	Mechanical Installation	5
3.4	Electrical Installation	7
04	System Start Up/ Shut Down	11
4.1	Power on Robot System	11
4.2	Shut down Robot System	13

1. About this Document

1.1 How to use the Quick Start Guide

This manual contains information that is necessary to use the robot. Read this manual and make sure that you understand the safety, assembly, maintenance, and operation of the CL robot series before attempting to use it. Read and understand the instructions. The user manual provides instructions for CL Series operators for the following aspects:

- Mechanical Installation: The operator **MUST** follow the instructions when installing the robot.
- Safety/ Security Configuration: Introduction the basic safety settings.

1.2 Related Documents

The CL robot system can be used both as stand-alone and as part of a system. Also follow the related manuals and the instructions for the other system components. This includes:

- User Manual
- GUI & Software Manual
- Service Manual

1.3 Robot Models

This manual provides information for the following CL Series models.

- CL103N
- CL105N
- CL108N
- CL110N

When information varies between different robot models, details are provided. When information is common to all robot models, an illustration of a single robot model is typically shown.

1.4 Technical Support

If you have any technical problems or other needs during use, visit our company website: www.kawasakirobotics.de, or directly contact our engineers.

1.5 Contact Information

Kawasaki Robotics GmbH

Im Taubental 32

41468 Neuss, Germany

Phone: +49 (0) 2131 3426 0

E-mail: info@kawasakirobotics.de

1.6 General Instructions

- Do not use the robot if it is damaged. Contact the technical support personnel of Kawasaki Robotics GmbH immediately.
- Observe the regulations for accident prevention and environmental protection for the country where the device is used.
- Kawasaki Robotics GmbH shall not be liable for any damage or personal injury caused to the robot due to errors in this script or improper operation of the robot.
- Take care of potential hazards leading to injuries and equipment damages when working with the robot system. Potential hazards are, for example:
 - Fingers are caught between the robot foot and the base.
 - Sharp edges on the tool or obstacles near the robot trajectory puncture the skin.
 - Injuries by a robot collision.
 - Consequences due to insecure bolts used to fix the robot arm or tool.

2. Inside the Box

⚠ IMPORTANT NOTE ⚠

Liability

Kawasaki Robotics GmbH shall not be liable for failure, indirect, incidental, or consequential damages, loss of profits or production devicit or commercial loss in any way connected with the CL Series safety standards.

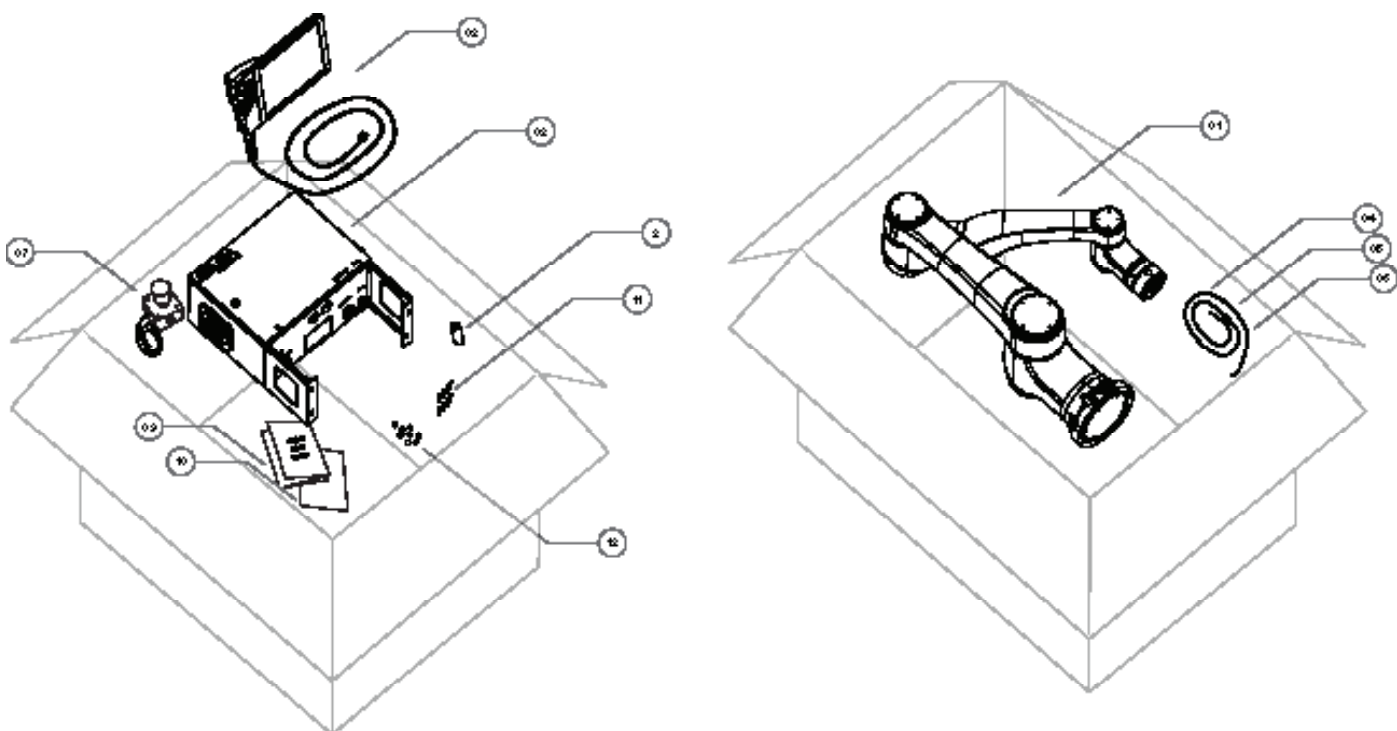

No.	Item	Quantity
01	CL Robot Arm	1
02	Electrical Control Box	1
03	Teach Pendant (incl. cable)	1
04	Power Supply Cable (5 meter)	1
05	Connecting Cable (5 meter)	1
06	IO Cable	1
07	Emergency Stop (incl. cable – 5 meter)	1
08	USB License Dongle	1
09	CL Quick Start Guide	1
10	Test Report	1
11	M6/M8 Screws + Washers	6/8
12	Control Box Keys	2

3. Installation

3.1 Installation flow chart

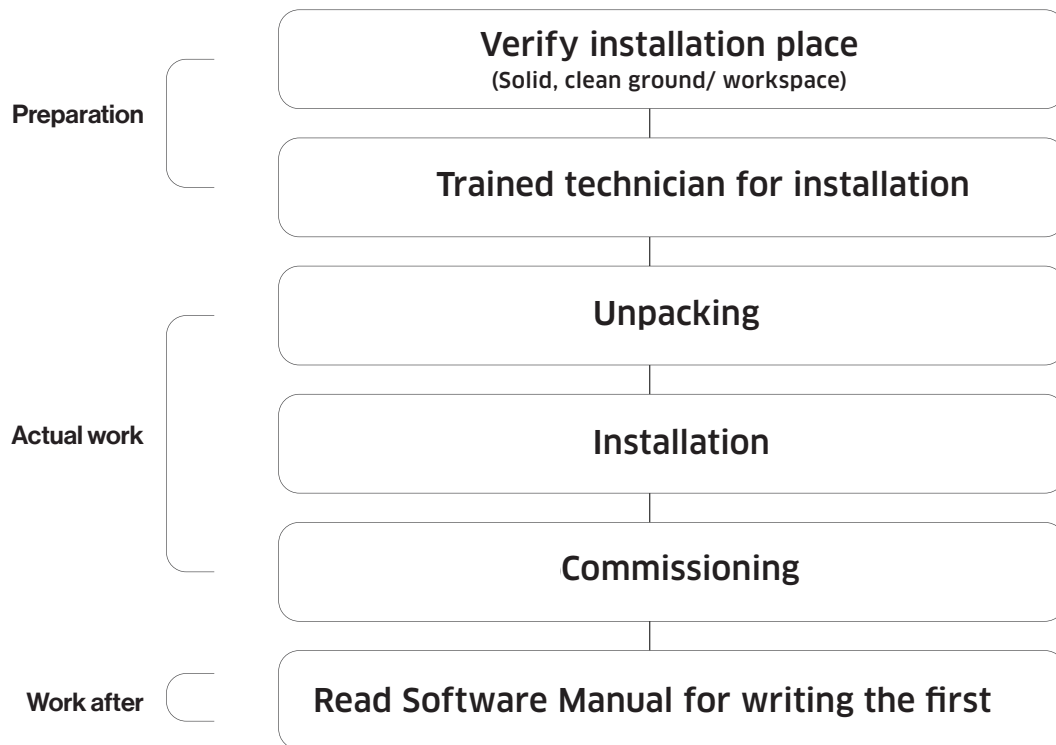

3.2 Unpacking



WARNING



Heavy weight of the device

The robot system is, packed or unpacked, heavy.

Improper handling may result in injury or damage to the device.

- Do not lift the robot (packed or unpacked) unassisted.
- Ensure that at least two people carry the robot together and hold firmly at the base while moving the robot.
- Obey all safety precautions while lifting the robot.
- Use proper lifting equipment and ensure that the lifting equipment can withstand the weight of the robot.
- Kawasaki Robotics GmbH cannot be held responsible for any damage caused by

- 1 The packaging boxes should be placed on a clean and stable surface on ground level.
- 2 Open both boxes.
- 3 Wear your personal protective equipment (PPE) like protective gloves before cutting the package sealings. Be aware of the instructions and handle the material gently. Keep the boxes in a dry place in case you need to repack and transport the robot in the future.
- 4 Take out the teach pendant incl. cable.
- 5 Grab the control box on the top handle and put it up right carefully.
- 6 Take out the control box and place it close to the designated place.
- 7 Open the second packaging, remove the covering foam.
- 8 Take out the robot arm by only handling it in the marked area.
- 9 See mechanical installation (chapter 3.3).

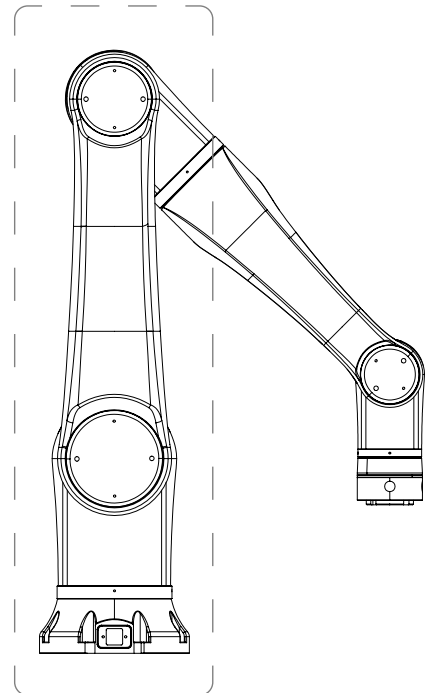

3.3 Mechanical Installation

Required tools

Knife/ Scissor

Allen key

- CL103N/CL105N - M6
- CL108N/CL110N - M8

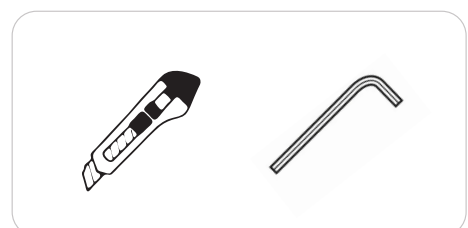

Robot Arm



CAUTION



Fastening the robot

Improper sequencing or torquing of the screws may result in damage

- Ensure that the screws are correctly tightened in a crosswise pattern with equal torque steps (50% and 100%).
- The installation platform should be at least 20 mm thick.
- No insulating layer material is allowed between the robot fixing plate and the robot.
- It is recommended that the steel plate should be used to suppress the vibration.

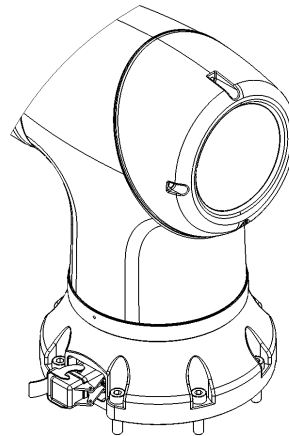
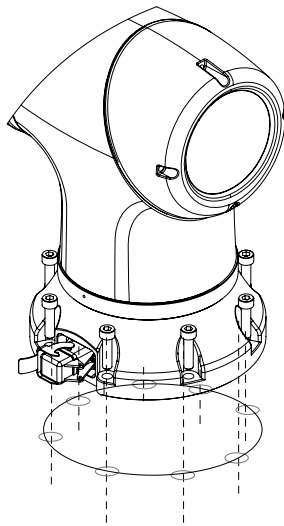

Fasten the CL103N/105N robots

- 1 Use 6x M6 screws (whose specifications meet ISO 898-1 performance level 10.9 or 12.9 mark) to fasten the CL103N/105N robots onto the mounting base with an allen key.
- 2 Use the torque of 13.2 Nm to tighten screws.

Fasten the CL108N/110N robots

- 1 Use 8x M8 screws (whose specifications meet ISO 898-1 performance level 10.9 or 12.9 mark) to fasten the CL108N/110N robots onto the mounting base with an allen key.
- 2 Use the torque of 32.08 Nm to tighten

Control Box

- 1 Place the control box next to the robot arm. Be aware of the environmental conditions written in the user manual.
- 2 Place the control box on a flat surface and make sure that the air vents and the control box door are not covered.
- 3 It is recommended to fix the control box feet to the ground by using the designated holes (screws are not included in the packaging).



3.4 Electrical Installation



DANGER



Installation and handling

Improper installation and handling of the device can lead to serious injuries.

- Do not disassemble the electrical control box, otherwise it may cause electric shock
- Ensure that the robot is properly grounded. If the grounding is not correct, it may cause a fire or electric shock.
- Hot plugging of cables and connectors is not allowed.
- Ensure that all connections are properly established before turning ON the power.

Connection Cable

- 1 Open the Harting connector on the robot base by pulling back the fixing flap and open the cap afterwards.

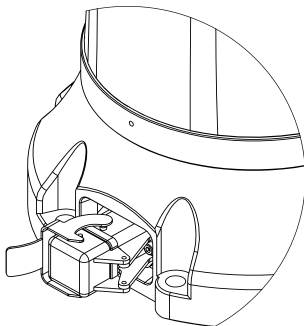

- 2 Take the grey end-connector and plug it in to the hole of the robot base connection and close the fixing flap.

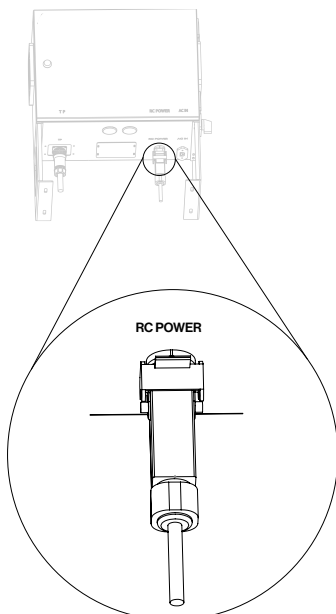
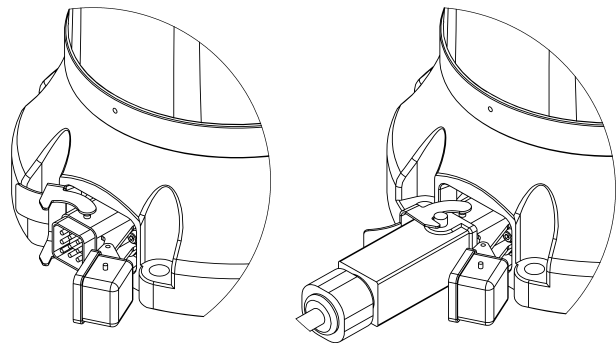

- 3 Plug in the other end of the cable to the RC power connection at the bottom of the control box.

- 4 Closing the fixing flap.

Power Supply Cable

- 1 Connect the power supply cable to the control box.
- 2 Do not connect the power supply cable to the 110-230 V/AC for now.

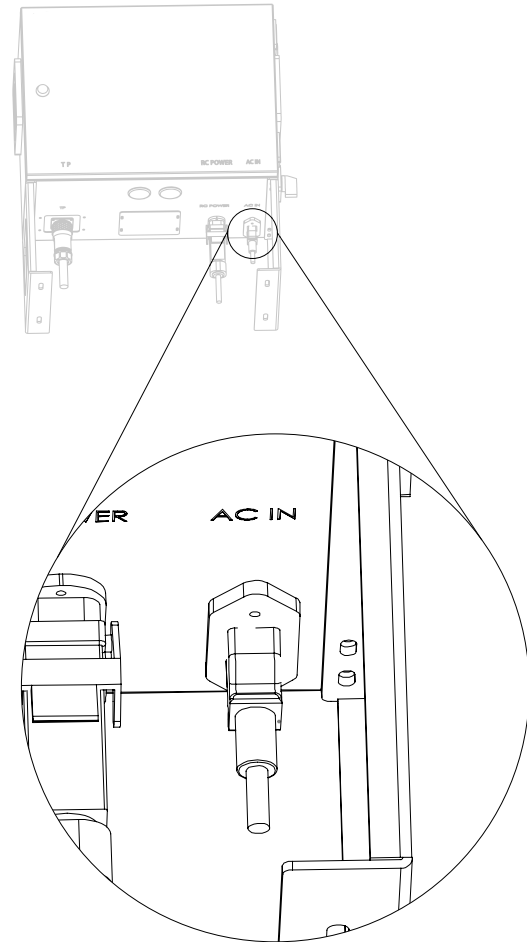

Teach Pendant Cable

- 1 Take the end of the teach pendant cable (silver connector).
- 2 Make sure the red point on the connector is in the same line as the red point on the teache pendant entrance on the control box. Plug in the connector to the control box.
- 3 Grooved plug cover must be pulled back and at the same time the plug must be connected upwards. It is important that the red marking (red dot) are aligned on both the plug and the socket. A clicking sound is heard when the con-

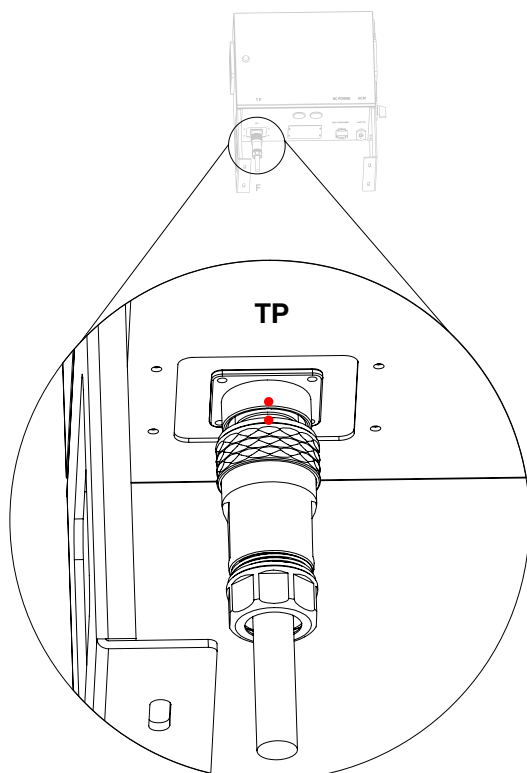

Emergency Stop Cable

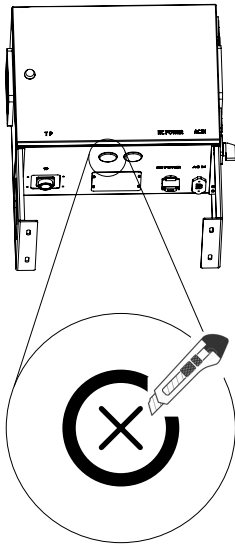

- ① Take the cable out of the package.
- ② Open the control box with the control box key.
- ③ Take out one of the round rubber gaskets from bottom of the control box and cut it crosswise.
- ④ Put the rubber back in the same place on the control box.
- ⑤ Feed the cable through the opening of the rubber cross.

- ⑥ Connect cable on main I/O board to the E-Stop connector pins.
- ⑦ Lock the control box with the control box key.
- ⑧ To run the robot, make sure the E-Stop is not pressed.

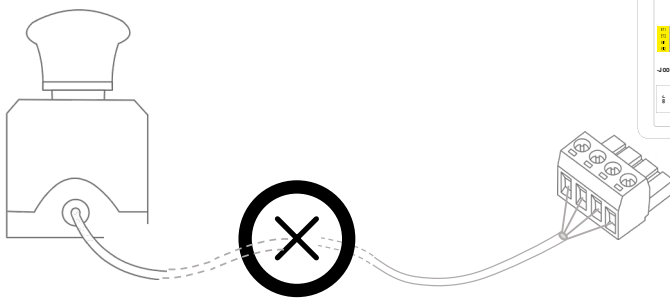

Emergency Stop unlocking

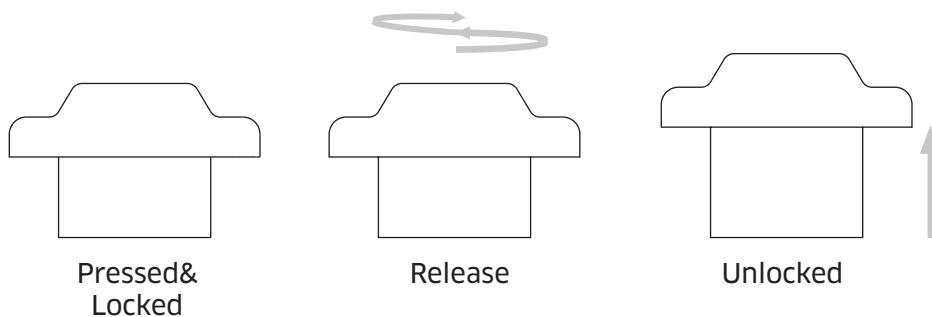

Ethernet Cable

- 1 Open the control box with the control box key.
- 2 Plug in the end of the cable to the Ethernet RJ45 connection at the bottom of the I/O panel in the control box.

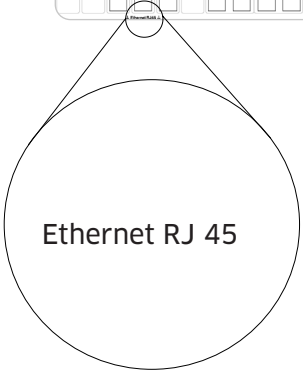

4. System Start Up/ Shut Down

4.1 Power on Robot System

⚠ WARNING ⚠

- Make sure that the robot is powered off and the control box is turned off (Main Power Switch on "0").
- Check and finish all mechanical/electrical installations before starting the system.
- The working area must be marked and secured/barricaded.

1 Plug in the power cable to 110/230 VAC.

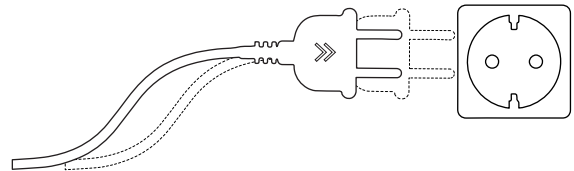

2 Switch on the power (control box).

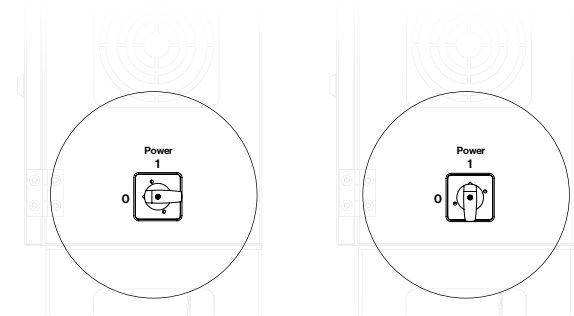

3 Make sure the teach pendant is charging. If charging symbol does not appear wait for 5 minutes to initially charge .

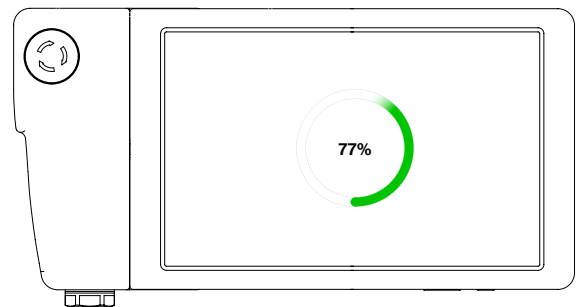

4 Turn on the robot IPC by pressing the power button.

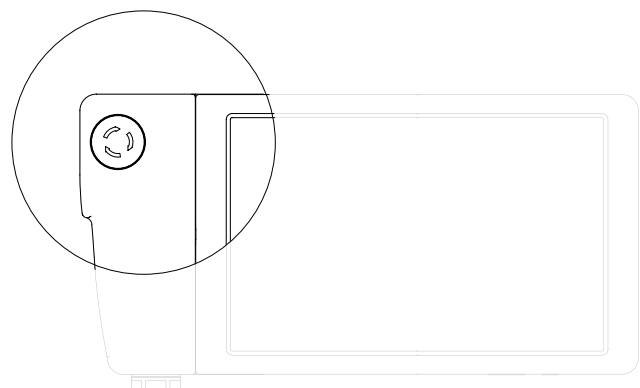

- 5 Turn on the teach pendant by pressing the small button for more than 10 seconds.

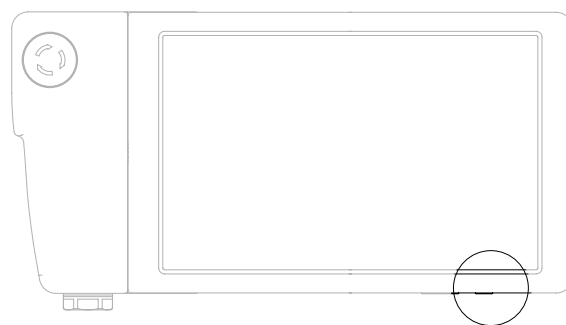

- 6 Press the E-Stop reset button on the control box (should light up white).

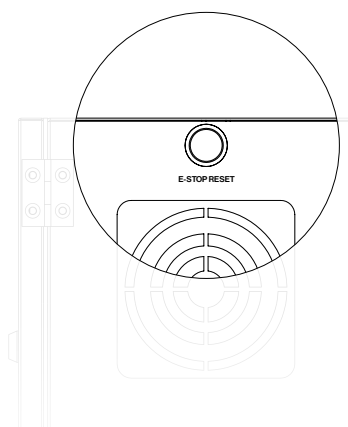

- 7 Login as Basic User.



- 8 Power on the robot.



- 9 For the next steps read the software manual.

4.2 Shut down Robot

- 1 Power off the robot in the GUI.

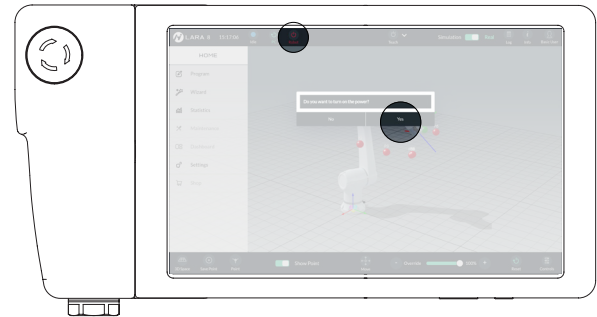

- 2 Power off the PC in the GUI.



- 3 Switch off the power (control box).

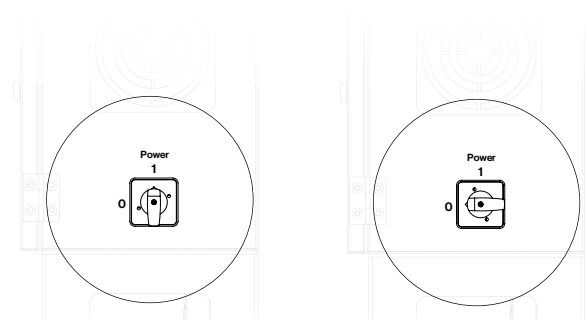

- 4 Teach pendant shuts off automatically after 10

- 5 Unplug the power cable.

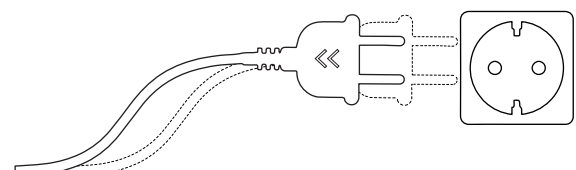

This document and all information contained herein is the sole property of Kawasaki Robotics GmbH. No intellectual property rights are granted by the delivery of this document or the disclosure of its content. This document shall not be reproduced or disclosed to a third party without the express written consent of Kawasaki Robotics GmbH. This document and its content shall not be used for any purpose other than that for which it is supplied. The statements made herein do not constitute an offer. They are based on the mentioned assumptions and are expressed in good faith. Where the supporting grounds for these statements are not shown, Kawasaki Robotics GmbH will be pleased to explain the basis thereof.

Kawasaki Robotics GmbH has made considerable efforts to ensure the content of this document is correct at the date of publication but does not give warranties regarding the content. Kawasaki Robotics GmbH excludes liability, howsoever arising, for any inaccuracies in this document.

© 2023 Kawasaki Robotics GmbH. All rights reserved.

Kawasaki Robotics GmbH reserves the right to change specifications without notice.

Kawasaki Robotics GmbH | Im Taubental 32 | 41468 Neuss
+49 (0) 2131 3426 0 | info@kawasakirobotics.de

www.kawasakirobotics.de