

PST230 / 460 / 900 / 1550SE

Payload capacity: 230 / 460 / 900 / 1550 kg
 JT1 rotating speed: 120 / 120 / 110 / 110 °/s

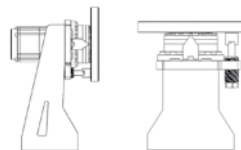

PST100E

Payload capacity: 100 kg
 JT1 rotating speed: 180 / 180 °/s

Repeatable parameters for all positioners:

Repeatability: +/-0.05 mm
 Mounting: floor
 Welding ground transfer system

Environmental conditions:
 • temperature: 0-40°C
 • humidity: 35-85%

Options for positioners



Positioning spacer for positioners in the workspace, maintains the proper distance between the module and the support unit. Compatible with positioners with support unit. Adjustable length.



Pedestal that increases the height of the positioner by 445 mm, with leveling holes. Compatible with PST125, PST250, PST500 positioners, also available as first axis, e.g. for F, G series.



Pneumatic brake with a solenoid valve. Mounted in selected support units.

Construction of welding positioners

Compact version

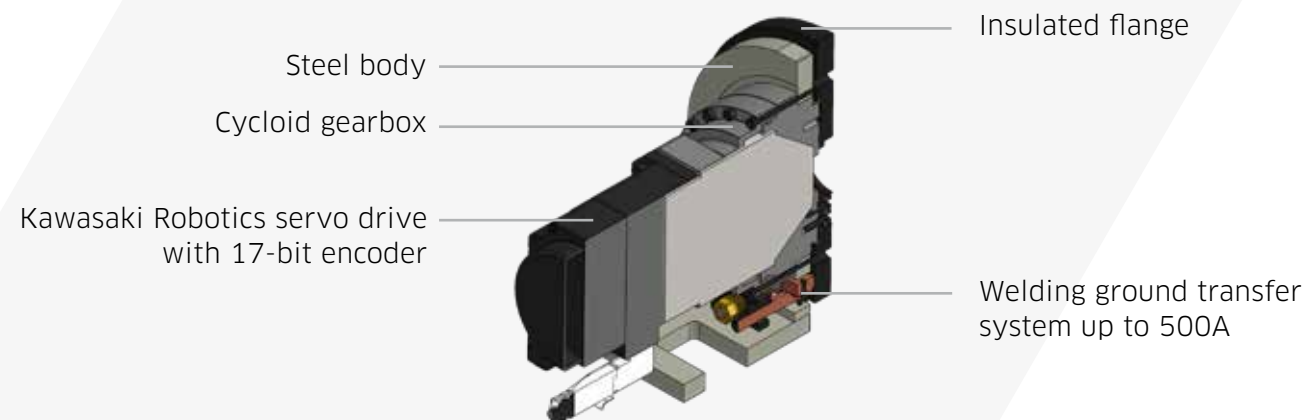

Standard version

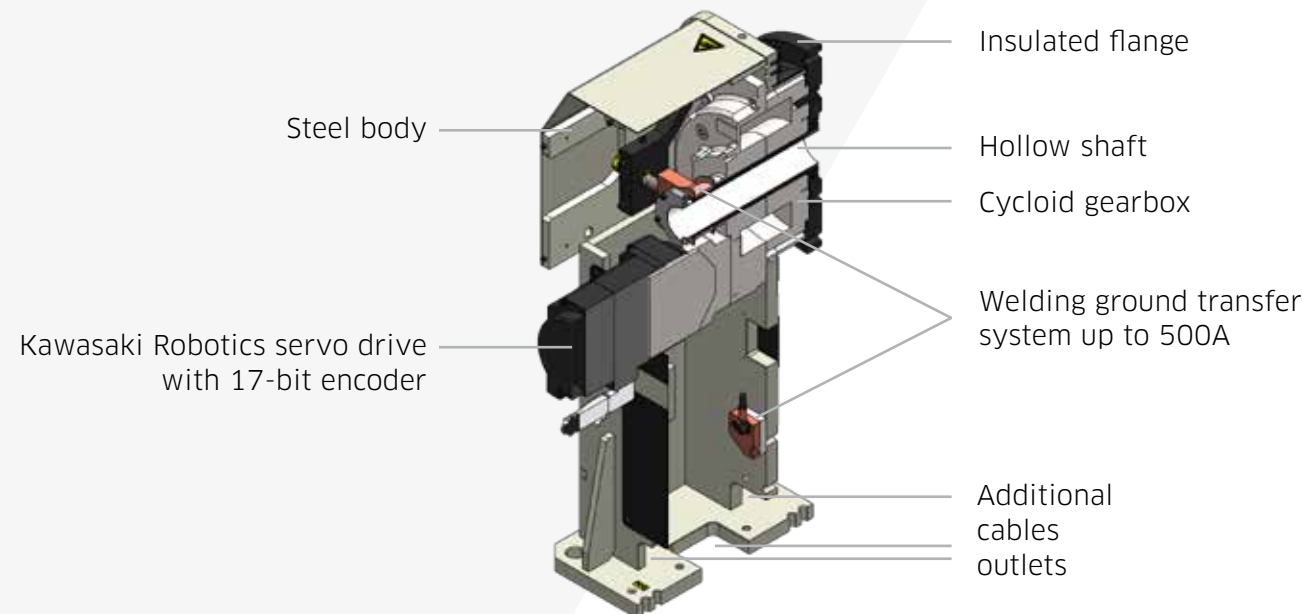

K-Positioner
 Maximizing precision and safety of welding with Kawasaki Robotics robots

Contact Us

Kawasaki Robotics (USA), Inc.
 28140 Lakeview Drive, Wixom, MI 48393,
 U.S.A. Phone: +1-248-446-4100
 Fax: +1-248-446-4200

Check the portfolio of positioners



All units are in metric system.

COMPACT SINGLE-AXIS POSITIONERS



PST230 / 460 / 900 / 1550E

Payload capacity: 230 / 460 / 900 / 1550 kg
Hollow shaft: no
Loading height: 131 / 158 / 185 / 185 mm
JT1 rotating speed: 120 / 120 / 110 / 110 °/s

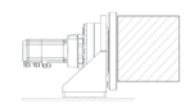

STANDARD SINGLE-AXIS POSITIONERS



PST125 / 250 / 500 / 1000 / 1000S / 2000

Payload capacity: 125 / 250 / 500 / 1000 / 1000 / 2000 kg
Hollow shaft: in JT1 drive
Loading height: 545 / 545 / 545 / 975 / 355 / 1025 mm
JT1 rotating speed: 180 / 150 / 150 / 110 / 110 / 70 °/s

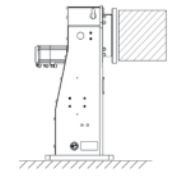

COMPACT SINGLE-AXIS POSITIONERS - H1-SERIES



PST230 / 460 / 900 / 1550E

Payload capacity: 230 / 460 / 900 / 1550 kg
Hollow shaft: in JT1 support unit
Loading height: 131 / 158 / 185 / 185 mm
JT1 rotating speed: 120 / 120 / 110 / 110 °/s

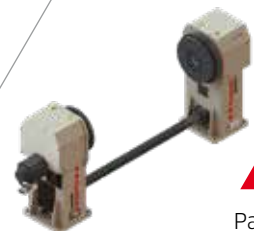
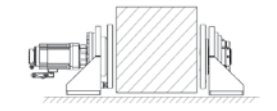

PST250 / 500 / 1000 / 2000 / 2000S / 3300 / 5000-H1

Payload capacity: 250 / 500 / 1000 / 2000 / 2000 / 3300 / 5000 kg
Hollow shaft: in JT1 drive and support unit
Loading height: 545 / 545 / 545 / 545 / 355 / 1025 / 1312 mm
JT1 rotating speed: 180 / 150 / 150 / 110 / 110 / 70 / 50 °/s

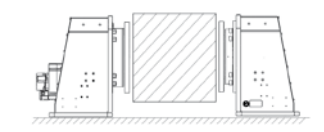

SINGLE-AXIS POSITIONERS - I-SERIES



PST180 / 375 / 750-I1

Payload capacity: 180 / 375 / 750 kg
Hollow shaft: in JT1 drive
Loading height: 702 / 702 / 702 mm
JT1 rotating speed: 180 / 150 / 150 °/s

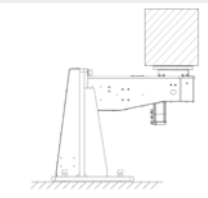

SINGLE-AXIS POSITIONERS - I-SERIES



PST1500 / 2500-I1

Payload capacity: 1500 / 2500 kg
Hollow shaft: in JT1 drive
Loading height: 649 / 778 mm
JT1 rotating speed: 110 / 60 °/s

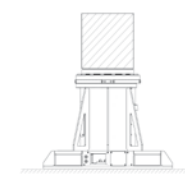

SINGLE-AXIS POSITIONERS - T-SERIES



PST125 / 250 / 500 / 1000-M1V1

Payload capacity: 125 / 250 / 500 / 1000 kg
Hollow shaft: in JT1 drive
Loading height: 862 / 862 / 862 / 1018 mm
JT1 rotating speed: 150 / 150 / 60 / 60 °/s

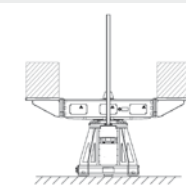

COMPACT TWO-AXIS POSITIONERS - F-SERIES



PST100 / 230 / 460E-F2

Payload capacity: 100 / 230 / 460 kg
Hollow shaft: in JT1 drive
Loading height: 680 / 670 mm
JT1 rotating speed: 150 / 150 °/s
JT2 rotating speed: 120 / 120 °/s

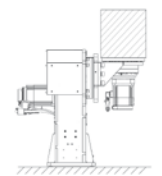

STANDARD TWO-AXIS POSITIONERS - F-SERIES



PST125 / 250-F2

Payload capacity: 125 / 250 kg
Hollow shaft: in JT1 and JT2 drives
Loading height: 710 / 710 mm
JT1 rotating speed: 150 / 150 °/s
JT2 rotating speed: 180 / 150 °/s

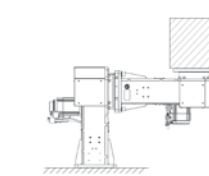

TWO-AXIS POSITIONERS - G-SERIES



PST250 / 500-G2

Payload capacity: 250 / 500 kg
Hollow shaft: in JT1 and JT2 drives
Loading height: 761 / 682 mm
JT1 rotating speed: 150 / 110 °/s
JT2 rotating speed: 150 / 150 °/s

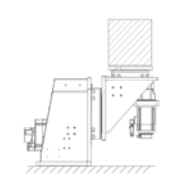

TWO-AXIS POSITIONERS - L-SERIES



PST125 / 250 / 500-L2 / 250-L2L

Payload capacity: 125 / 250 / 500 / 250 kg
Hollow shaft: in JT1 and JT2 drives
Loading height: 805 / 805 / 700 / 700 mm
JT1 rotating speed: 150 / 150 / 110 / 110 °/s
JT2 rotating speed: 180 / 150 / 150 / 150 °/s

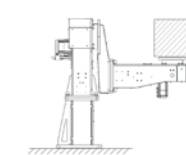

TWO-AXIS POSITIONERS - U-SERIES



PST2000-U2

Payload capacity: 2000 kg
Hollow shaft: in JT1 drive and support unit, in JT2 drive
Loading height: 614 mm
JT1 rotating speed: 50 °/s
JT2 rotating speed: 70 °/s

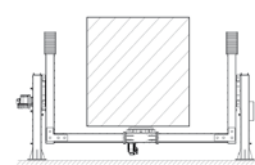

COMPACT THREE-AXIS POSITIONERS - H-SERIES



PST230 / 460E-M3-H2V1

Payload capacity: 230 / 460 kg
Hollow shaft: in JT1 drive and in JT2, JT3 support units
Loading height: 755 / 930 mm
JT1 rotating speed: 77 / 60 °/s
JT2/3 rotating speed: 120 / 120 °/s
Flange spacing: 1600 / 2000 / 2500 mm

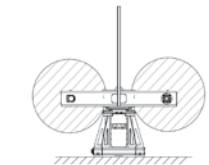

STANDARD THREE-AXIS POSITIONERS - H-SERIES



PST250 / 500 / 1000-M3-H2V1

Payload capacity: 250 / 500 / 1000 kg
Hollow shaft: in JT1 drive and in JT2 and JT3 drives and support units
Loading height: 1035 / 1035 / 1035 mm
JT1 rotating speed: 74 / 70 / 60 °/s
JT2/3 rotating speed: 180 / 150 / 150 °/s
Flange spacing: 1200 / 1600 / 2000 / 2500 mm

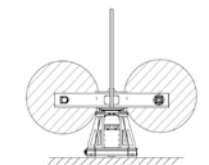

THREE-AXIS POSITIONERS - K-SERIES



PST125 / 250 / 500 / 1000-M3H3

Payload capacity: 125 / 250 / 500 / 1000 kg
Hollow shaft: in JT1 drive, in JT2, JT3 drives and support units
Loading height: 975 / 975 / 975 mm
JT1 rotating speed: 60 / 60 / 60 / 60 °/s
JT2/3 rotating speed: 180 / 180 / 150 / 120 °/s
Flange spacing: 2000 / 2500 / 3000 / 3500 mm

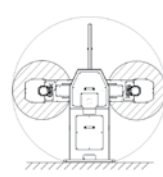

THREE-AXIS POSITIONERS - K-SERIES, HIGH



PST125 / 250 / 500 / 1000-M3H3

Payload capacity: 125 / 250 / 500 / 1000 kg
Hollow shaft: in JT1 drive, in JT2, JT3 drives and support units
Loading height: 963+785 / 963+785 / 963+785 mm
JT1 rotating speed: 60 / 60 / 60 / 60 °/s
JT2/3 rotating speed: 180 / 180 / 150 / 120 °/s
Flange spacing: 2000 / 2500 / 3000 / 3500 mm

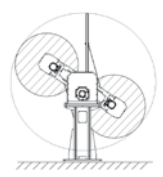

THREE-AXIS POSITIONERS - V-SERIES



PST180 / 375 / 750-M3V3

Payload capacity: 180 / 375 / 750 kg
Hollow shaft: in JT1 drive, JT2, JT3
Loading height: 865 / 865 / 865 mm
JT1 rotating speed: 74 / 70 / 60 °/s
JT2/3 rotating speed: 180 / 150 / 150 °/s

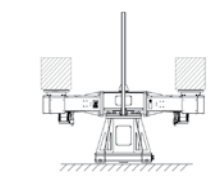

FIVE-AXIS POSITIONERS - W-SERIES



PST125 / 250 / 500-M5-H2V3

Payload capacity: 125 / 250 / 500 kg
Hollow shaft: in JT1, JT2, JT3, JT4, JT5 drives
Loading height: 767 / 816 / 866 mm
JT1 rotating speed: 60 / 60 / 60 °/s
JT2/4 rotating speed: 150 / 150 / 110 °/s
JT3/5 rotating speed: 180 / 150 / 150 °/s

