



Standard Specifications

KJ264J-B

KJ264J-D

KJ264J-F

KJ264J-H

(for E controller)

1st ed. 06-Sep-17

2nd ed. 31-Jan-25

Kawasaki Heavy Industries, Ltd.
Robot Business Division

Specification number : 90151-0210DEB

Robot specifications

1. Model	Installation mode		Standard	Mirror
	Floor		KJ264J-B0	KJ264J-B1
	Mounting wall is left side		KJ264J-D0	KJ264J-D1
	Mounting wall is right side		KJ264J-F0	KJ264J-F1
	Shelf		KJ264J-H0	KJ264J-H1
2. Type	Articulated robot			
3. Degree of freedom	6 axes			
4. Max. payload	Wrist : 15 kg (at the tool mounting surface) Upper arm : 25 kg (including painting equipment in the pressurized chamber)			
5. Max. reach	2,640 mm			
6. Position repeatability	±0.5 mm (wrist flange surface) conforms to ISO 9283			
7. Max. painting speed	1,500 mm/s (at the center of tool mounting surface)			
8. Axis specification	Operating axis		Motion range	
	Arm rotation (JT1)	KJ264J-B□	±120°	
		KJ264J-D□	+ 120° - - 30°	
		KJ264J-F□	+ 30° - - 120°	
		KJ264J-H□	±120°	
	Arm out-in (JT2)	+ 130° - - 80°		
	Arm up-down (JT3)	+ 90° - - 65°		
	Wrist swivel (JT4)	±720°		
Wrist bend (JT5)	±720°			
Wrist twist (JT6)	±410°			
9. Load capacity of wrist	Max. torque		Moment of inertia*	
	JT4	56.2 N·m	2.19 kg·m ²	
	JT5	43.4 N·m	1.31 kg·m ²	
	JT6	22.0 N·m	0.33 kg·m ²	
	Note * Each value in this table shows allowable moment of inertia of JT4/JT5/JT6 when max. allowed torque is applied to each axis. If more detailed data is required for your application, please contact Kawasaki.			
10. Mass	KJ264J-B□	540 kg (without options)		
	KJ264J-D□, -F□, -H□	530 kg (without options)		
11. Mounting	KJ264J-B□(Floor)	KJ264J-D□(Mounting wall is left side)		
	KJ264J-F□(Mounting wall is right side)	KJ264J-H□(Shelf)		
12. Installation Environment	Ambient Temperature :	0 - 40 °C		
	Relative Humidity :	35 - 85 % (with no dew condensation)		
13. Color	Munsell 10GY9/1 equivalent			
14. Explosion proof	Pressurized and intrinsically safe			
15. Air supply to the manipulator	Clean & dry air	0.5 Nm ³ /min, 0.4 - 0.7 MPa		
	Dew point	- 17 or less at atmospheric pressure		
	Solid material	0.01 μm or less		
	Oil content	Mist separation 99.9999% or more		
16. Options	Mechanical stopper	Adjustable stoppers JT1/JT2/JT3		
	Painting equipment	FGP motor (1 unit can be equipped with)		
		Solenoid valve for painting (up to 3 units can be equipped with)		
		Electro pneumatic converter for painting (up to 3 units can be equipped with)		
	Upper Arm Cover			
	Application hose protection unit			

Consult Kawasaki about maintenance parts and spare parts.

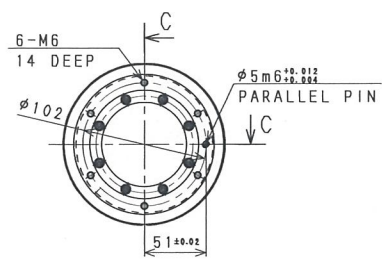

VIEW B

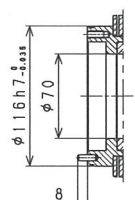

SECTION C-C

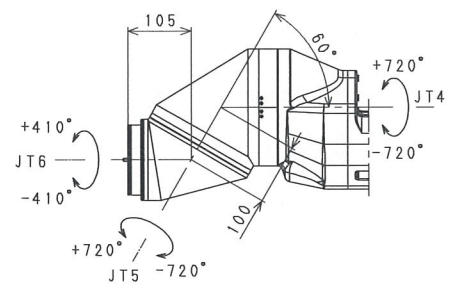

DETAIL A

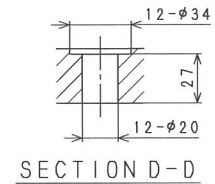

SECTION D-D

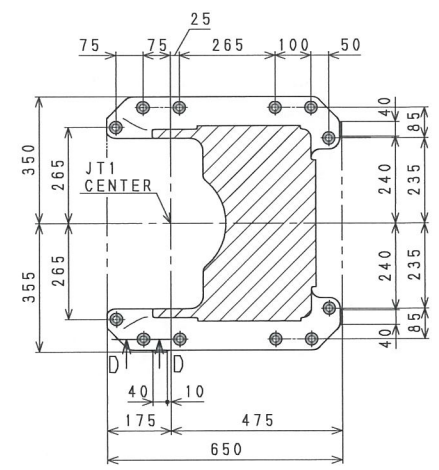

Base Installation Dimensions

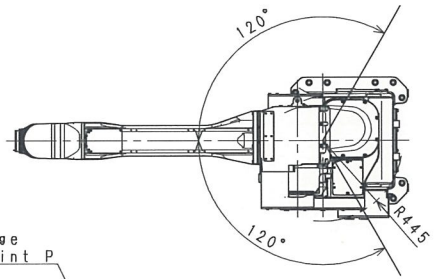

Working range based on point P

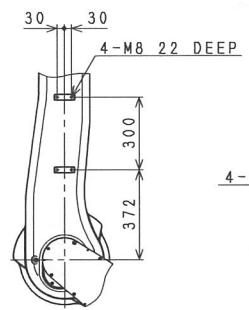

VIEW E

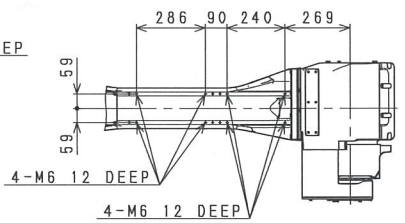

VIEW F

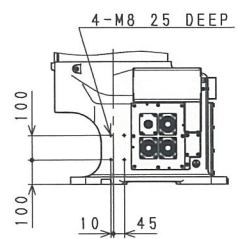
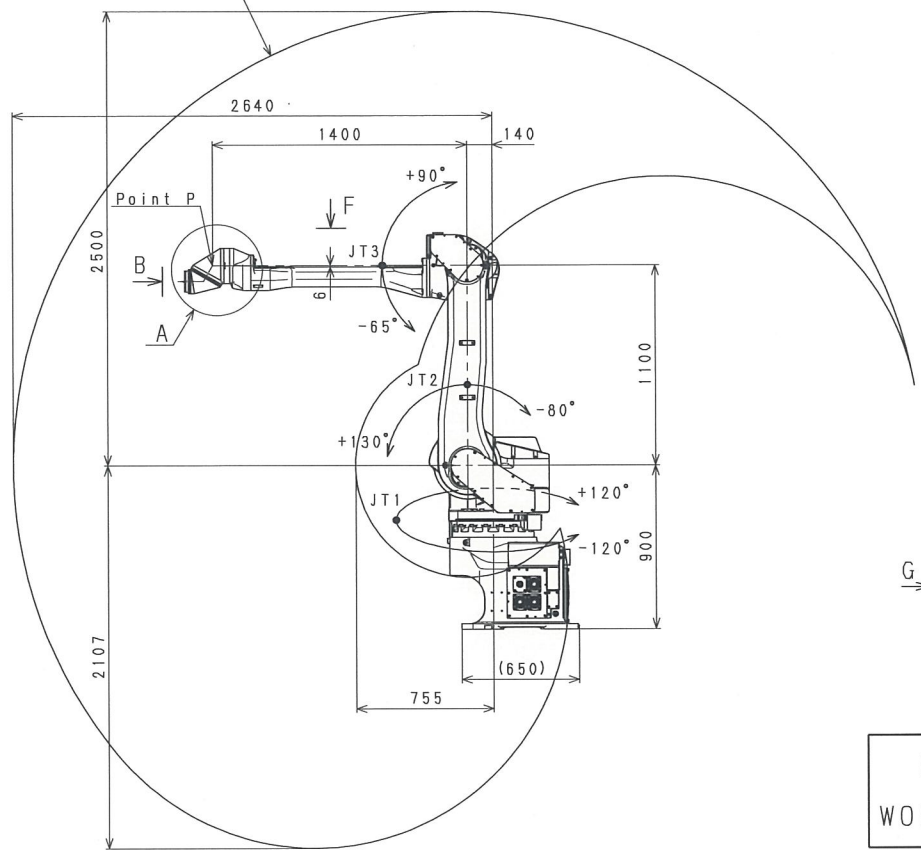

VIEW G

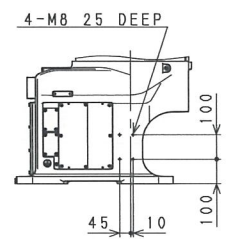

VIEW H

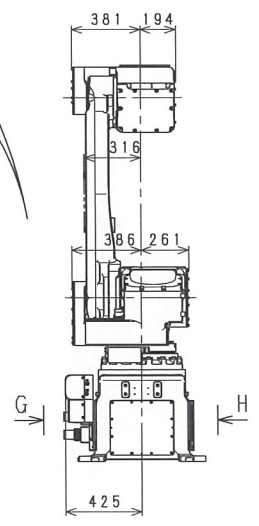
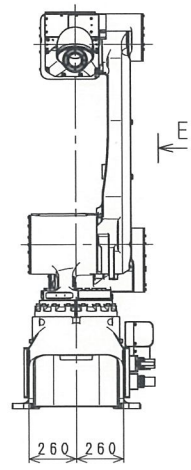

KJ264J-B0
WORKING RANGE

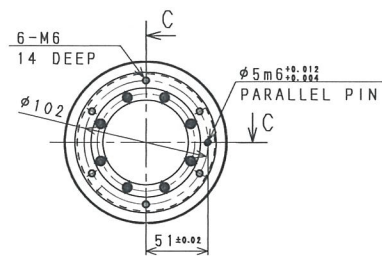

VIEW B

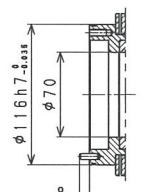

SECTION C-C

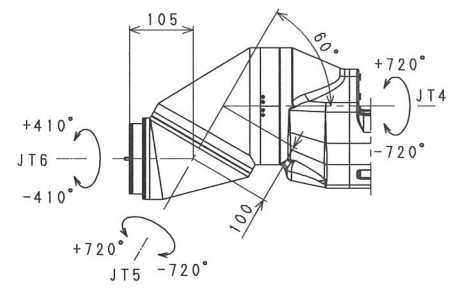

DETAIL A

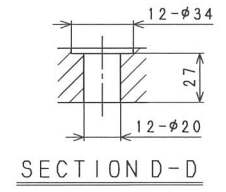

SECTION D-D

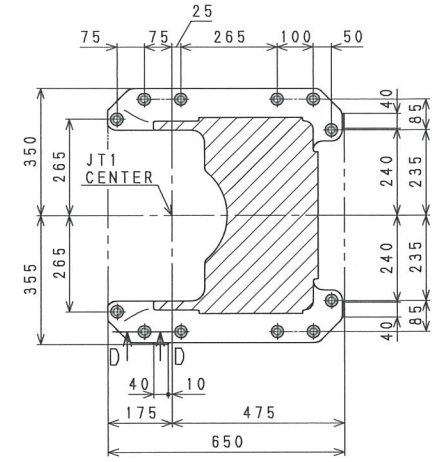

Base Installation Dimensions

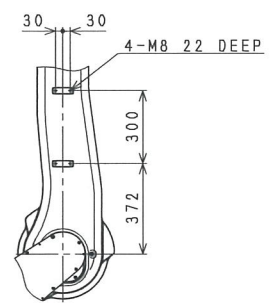

VIEW E

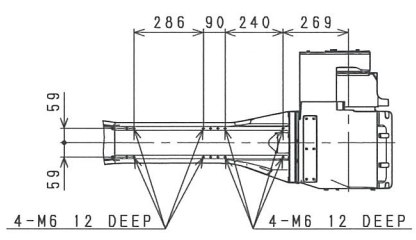

VIEW F

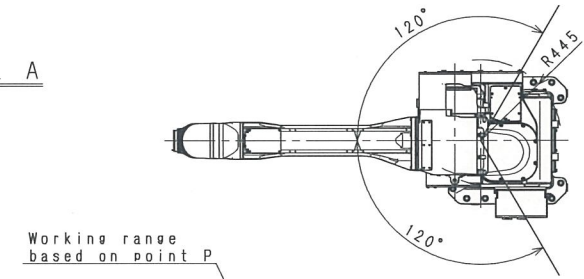

Working range based on point P

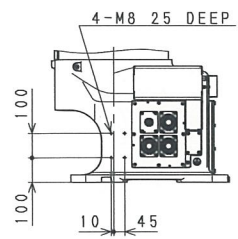
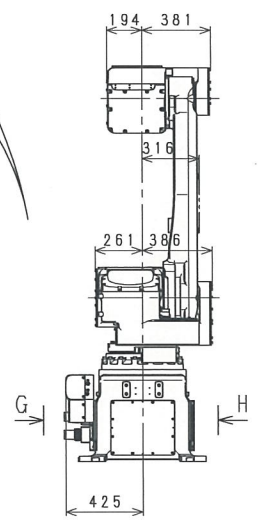
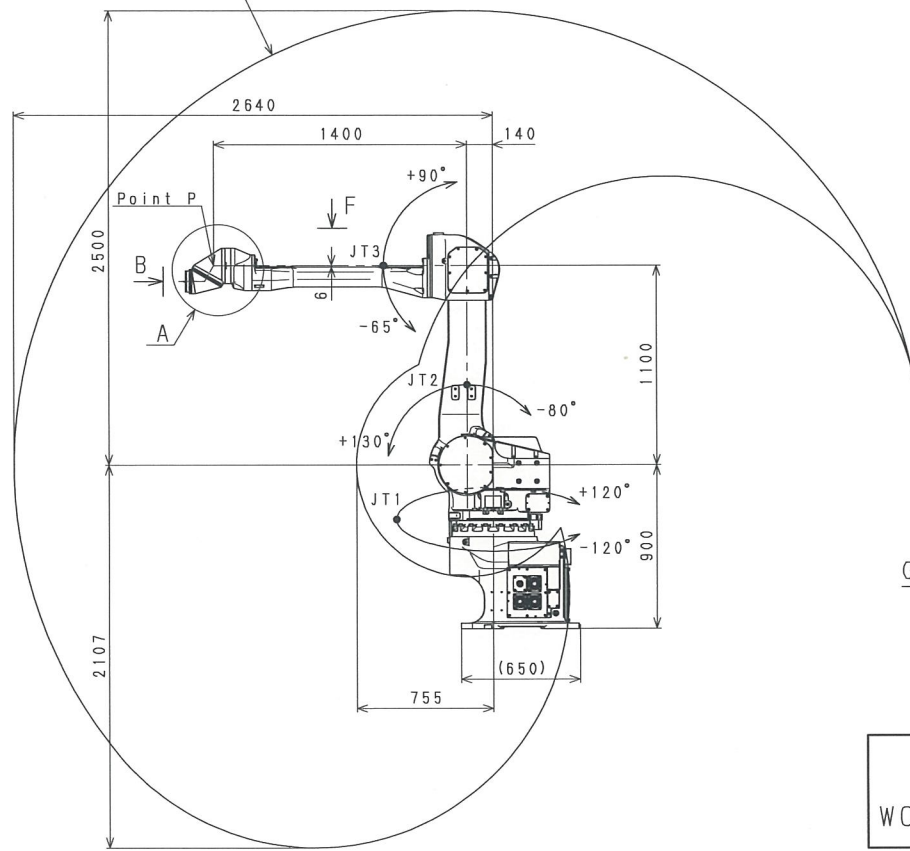

VIEW G

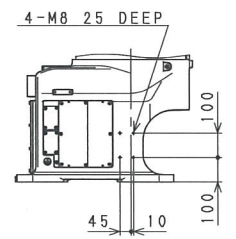

VIEW H

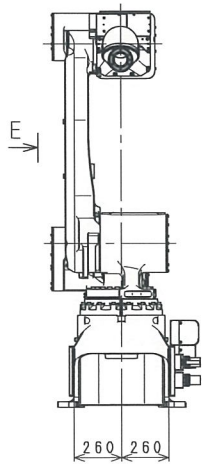

VIEW I

KJ264J-B1
WORKING RANGE

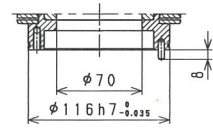

SECTION C-C

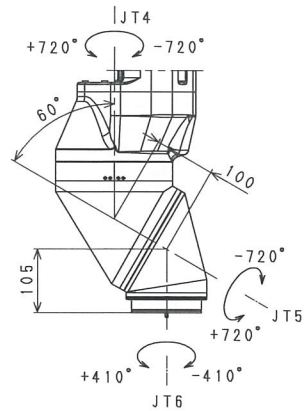

DETAIL A

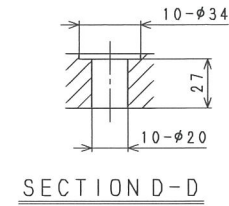

SECTION D-D

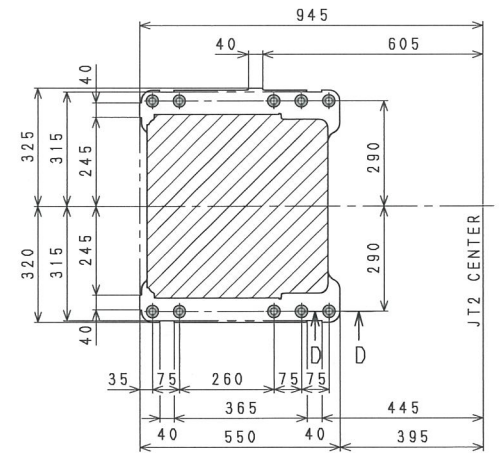

Base Installation Dimensions

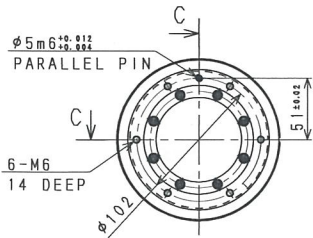

VIEW B

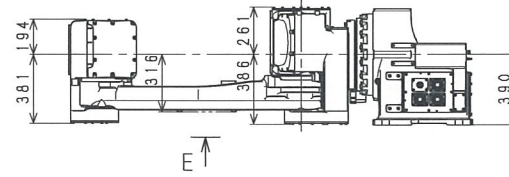

E

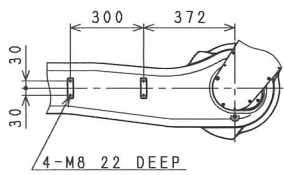

VIEW E

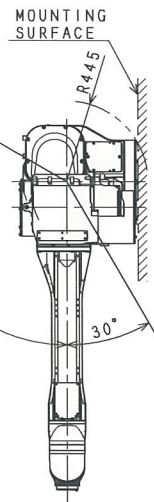

MOUNTING SURFACE

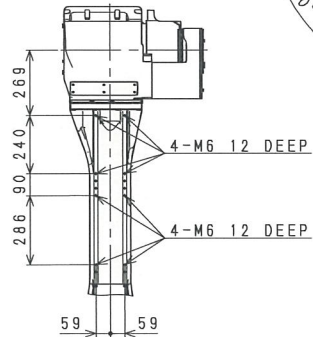

VIEW F

Working range based on point P

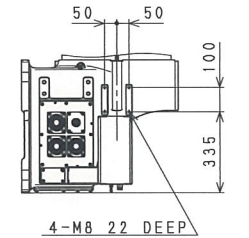
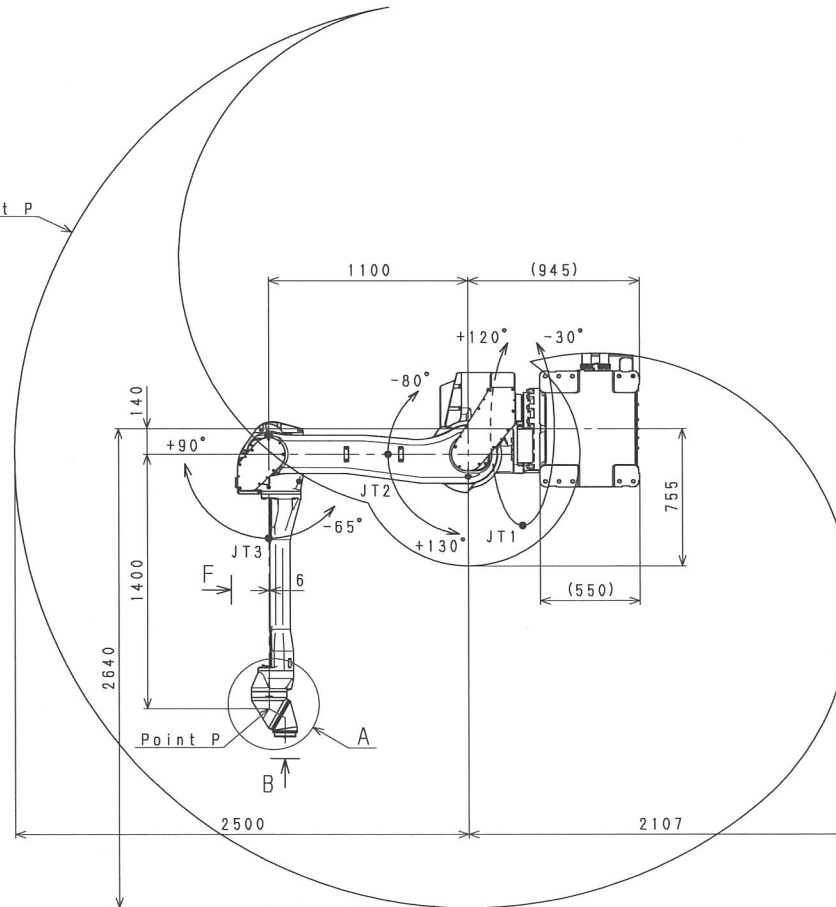

VIEW G

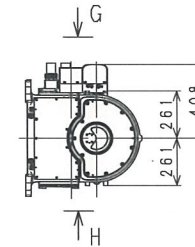

H

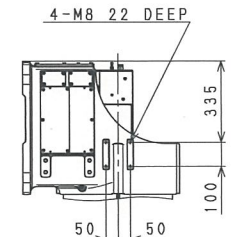

VIEW H

KJ264J-D0
WORKING RANGE

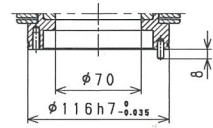

SECTION C-C

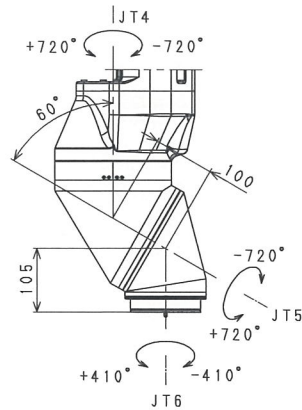

DETAIL A

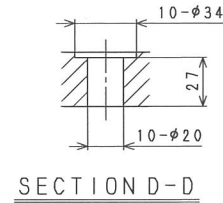

SECTION D-D

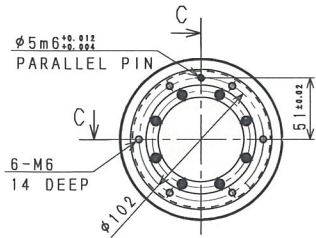
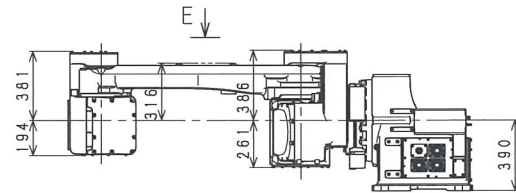

VIEW B

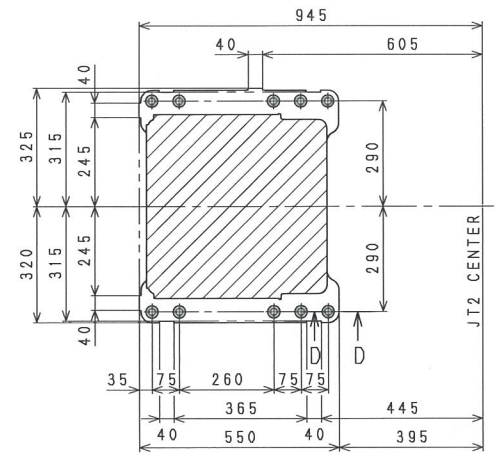

Base Installation Dimensions

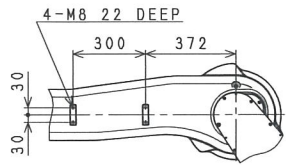

VIEW E

Working range based on point P

MOUNTING SURFACE

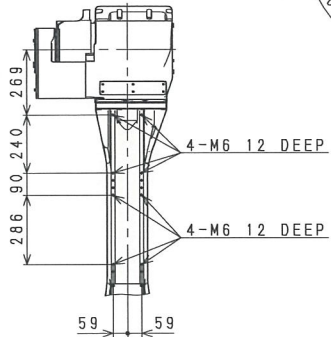
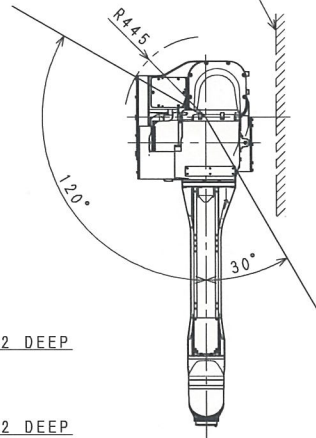

VIEW F

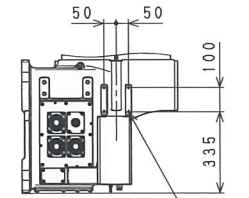
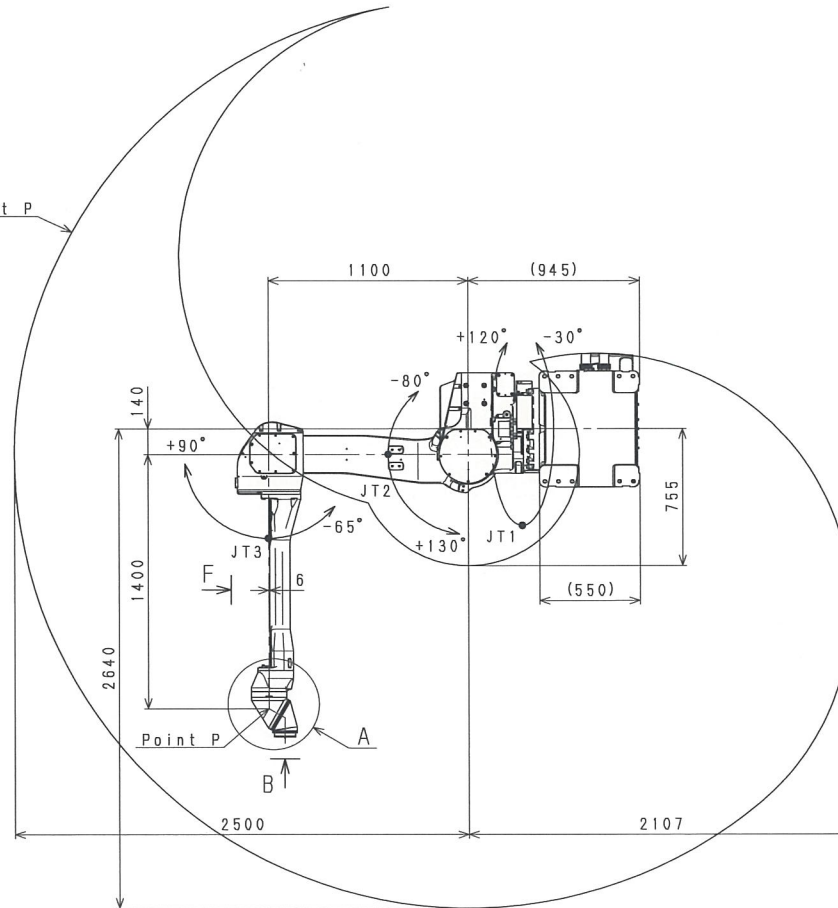

4-M8 22 DEEP

VIEW G

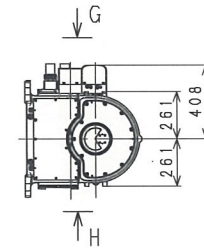

4-M8 22 DEEP

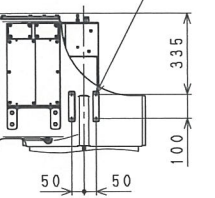

VIEW H

KJ264J-D1
WORKING RANGE

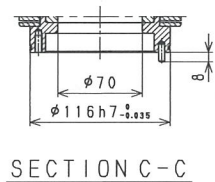

SECTION C-C

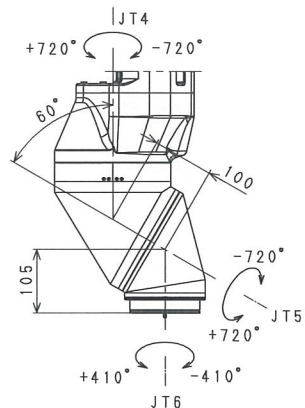

DETAIL A

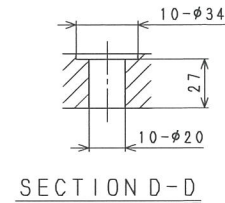

SECTION D-D

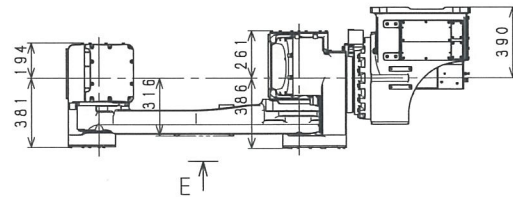

E

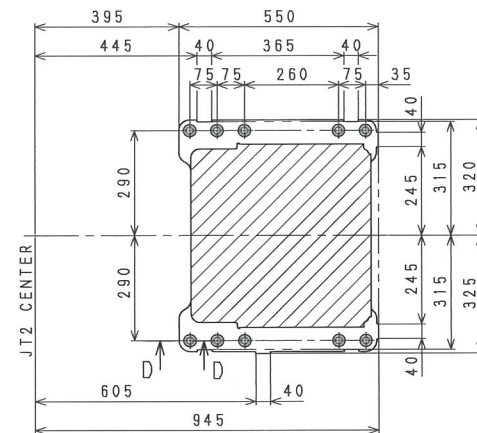

Base Installation Dimensions

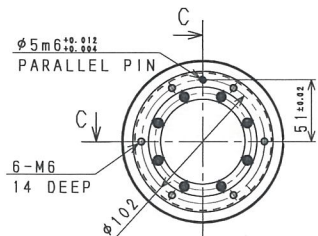

VIEW B

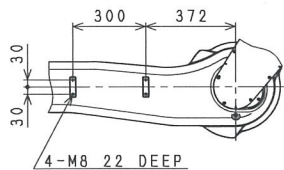

VIEW E

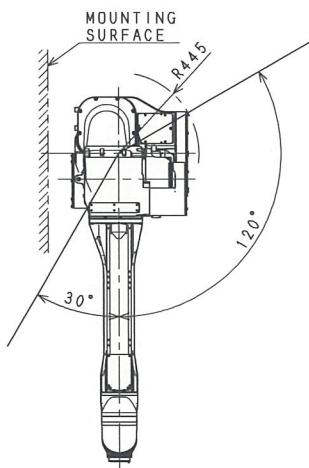

Working range based on point P

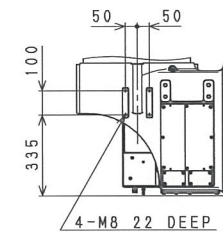
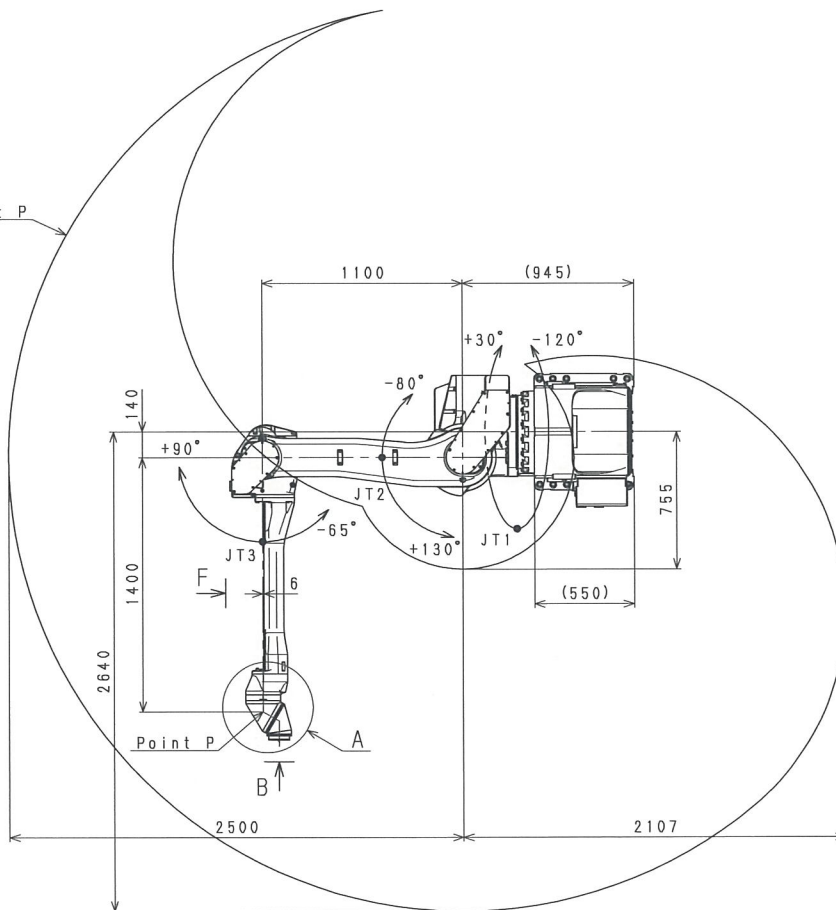

VIEW H

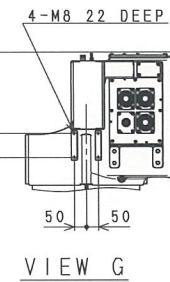
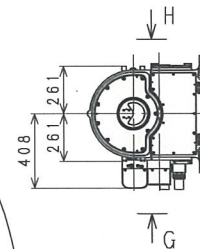

VIEW G

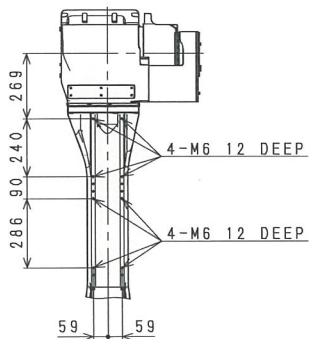

VIEW F

KJ264J-F0
WORKING RANGE

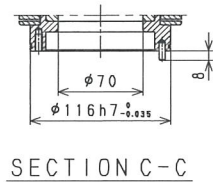

SECTION C-C

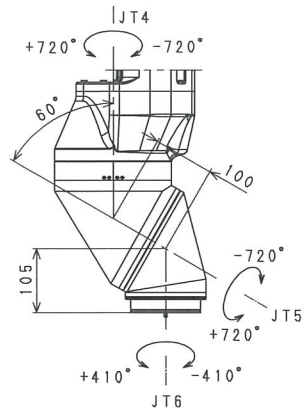

DETAIL A

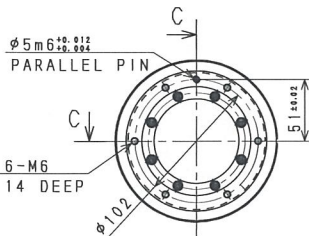

VIEW B

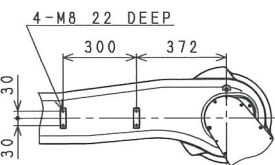

VIEW E

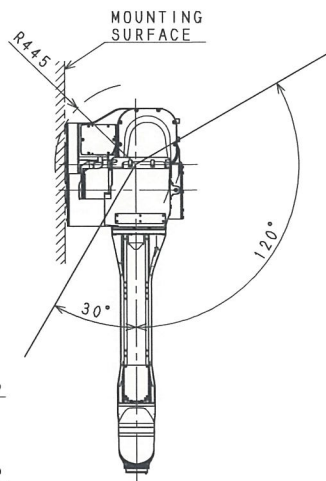

MOUNTING SURFACE

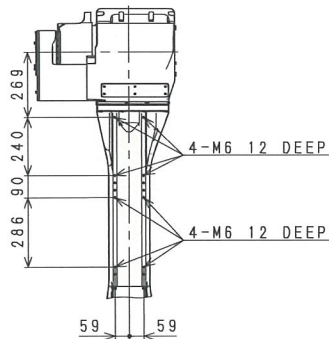

VIEW F

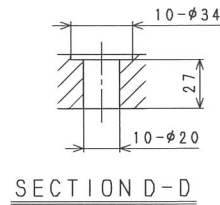

SECTION D-D

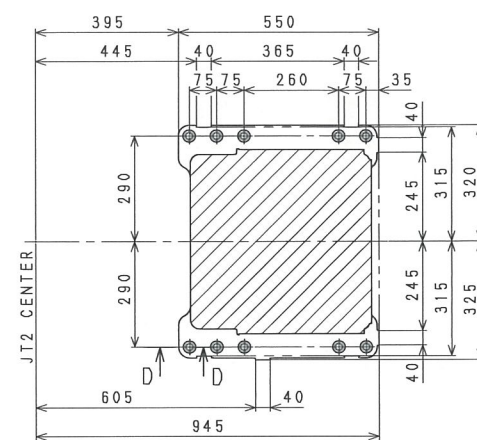
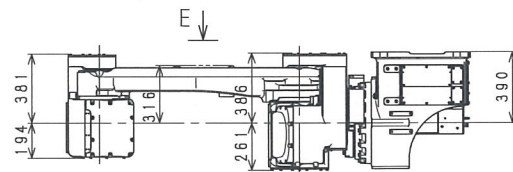

Base Installation Dimensions

Working range based on point P

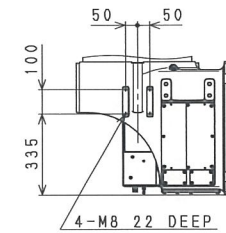
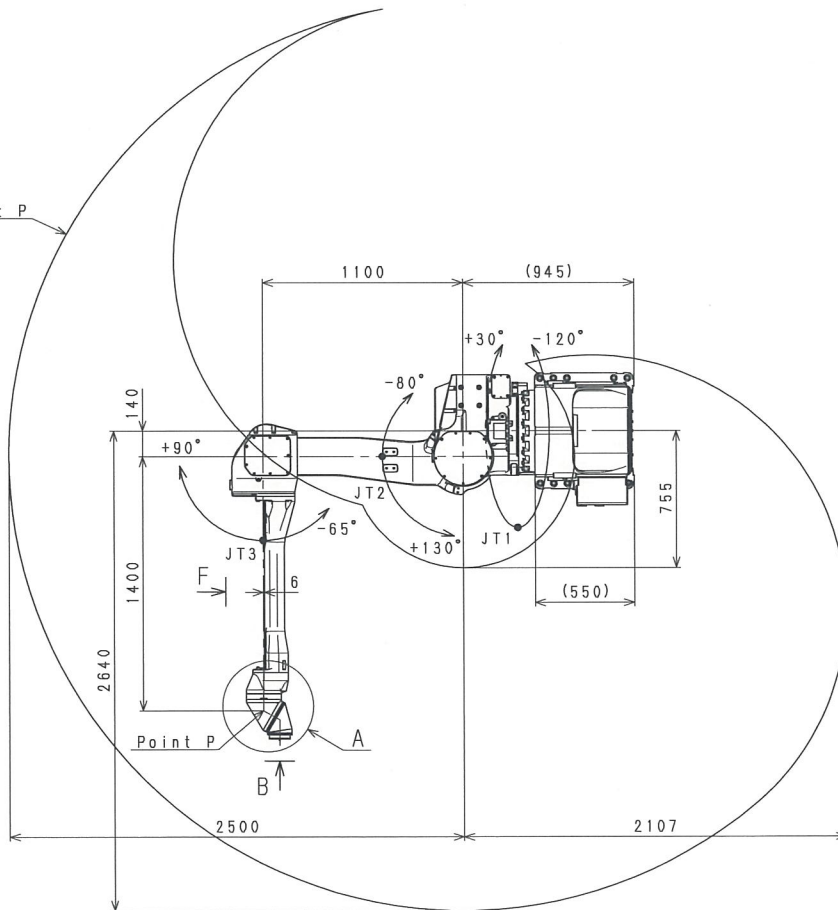

VIEW H

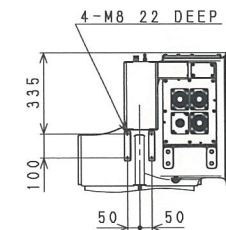
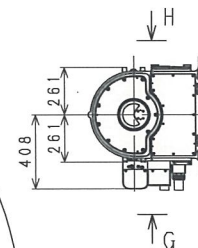

VIEW G

KJ264J-F1
WORKING RANGE

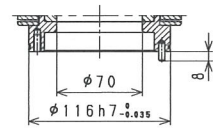

SECTION C-C

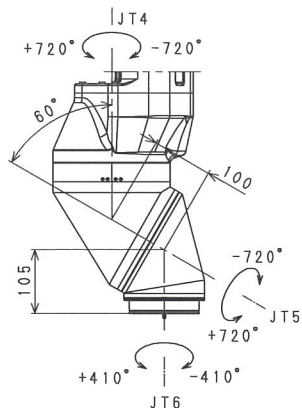

DETAIL A

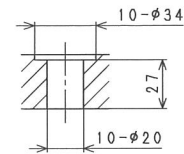

SECTION D-D

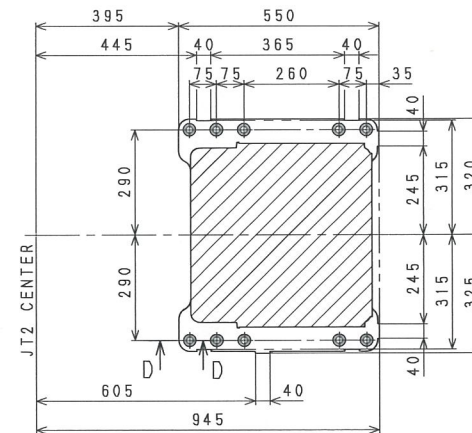

Base Installation Dimensions

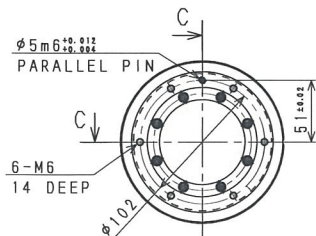

VIEW B

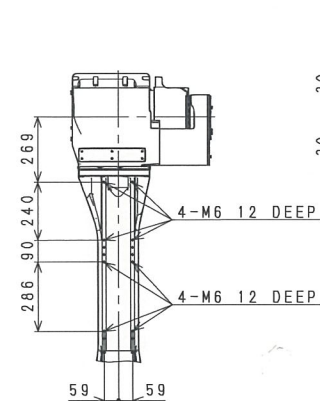

VIEW F

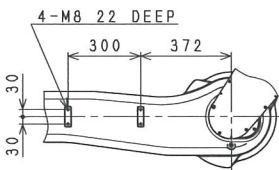

VIEW E

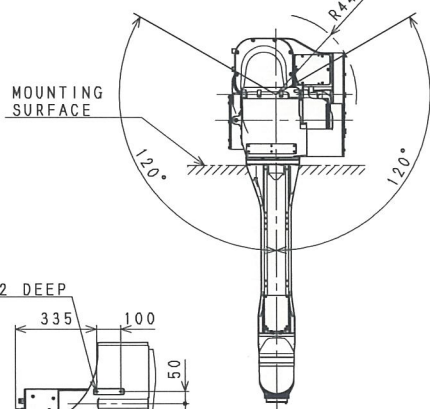

VIEW H

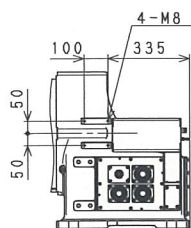

VIEW G

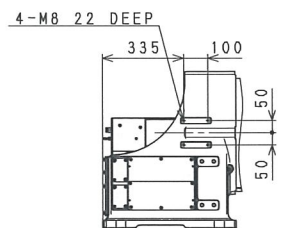

Working range based on point P

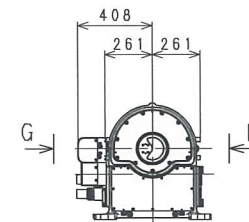
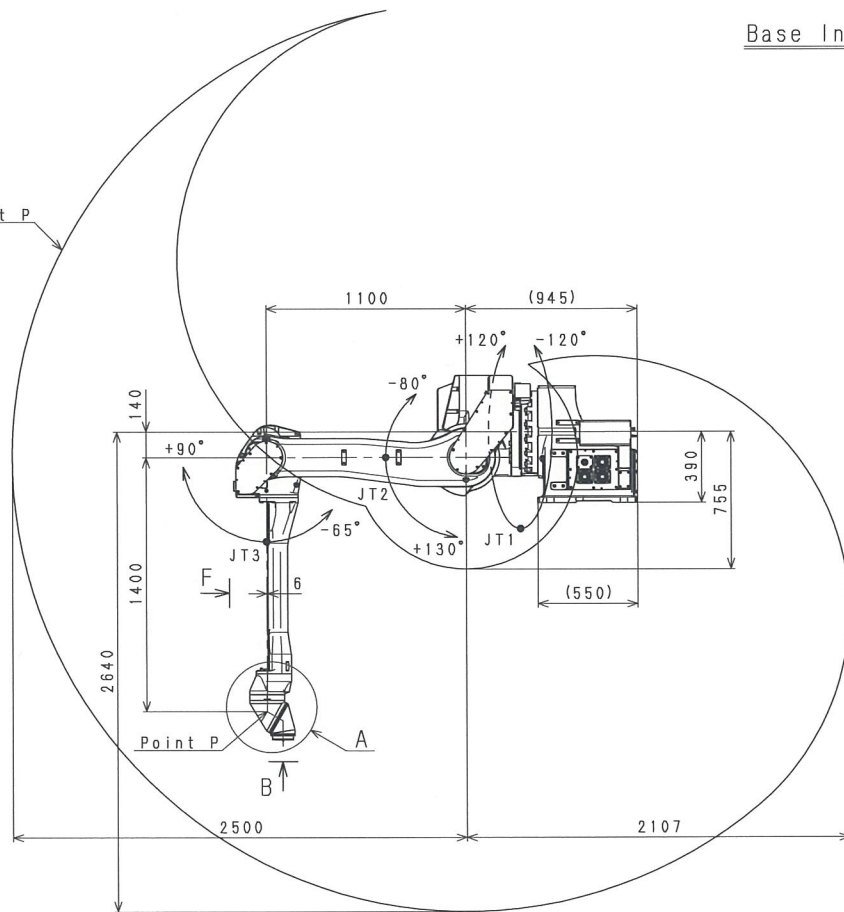

KJ264J-H0
WORKING RANGE

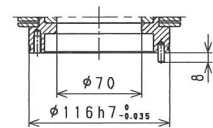

SECTION C-C

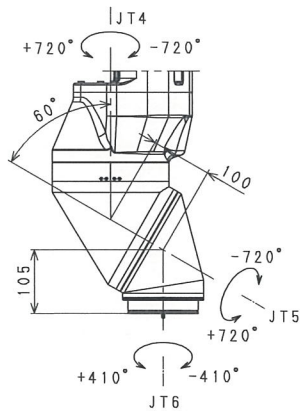

DETAIL A

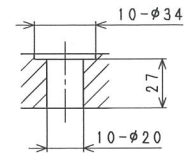

SECTION D-D

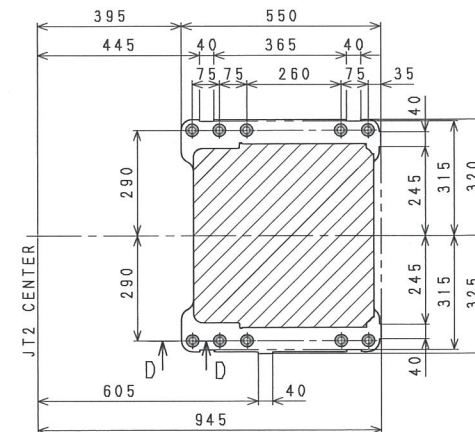

Base Installation Dimensions

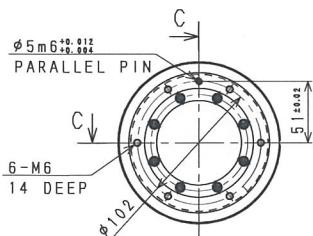

VIEW B

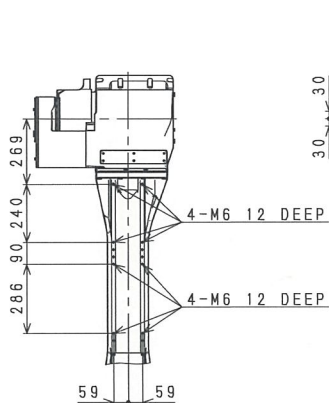

VIEW F

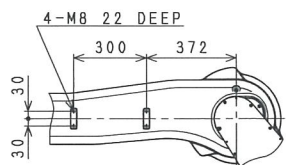

VIEW E

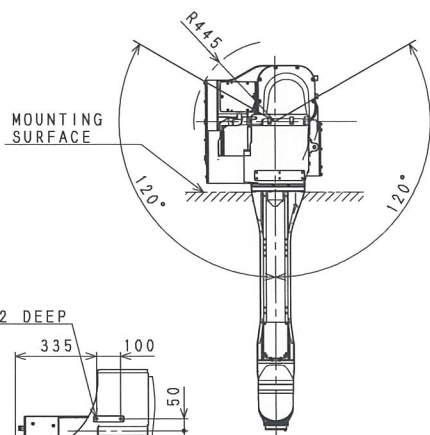

VIEW H

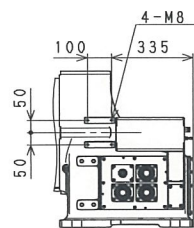

VIEW G

Working range based on point P

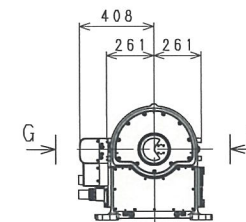
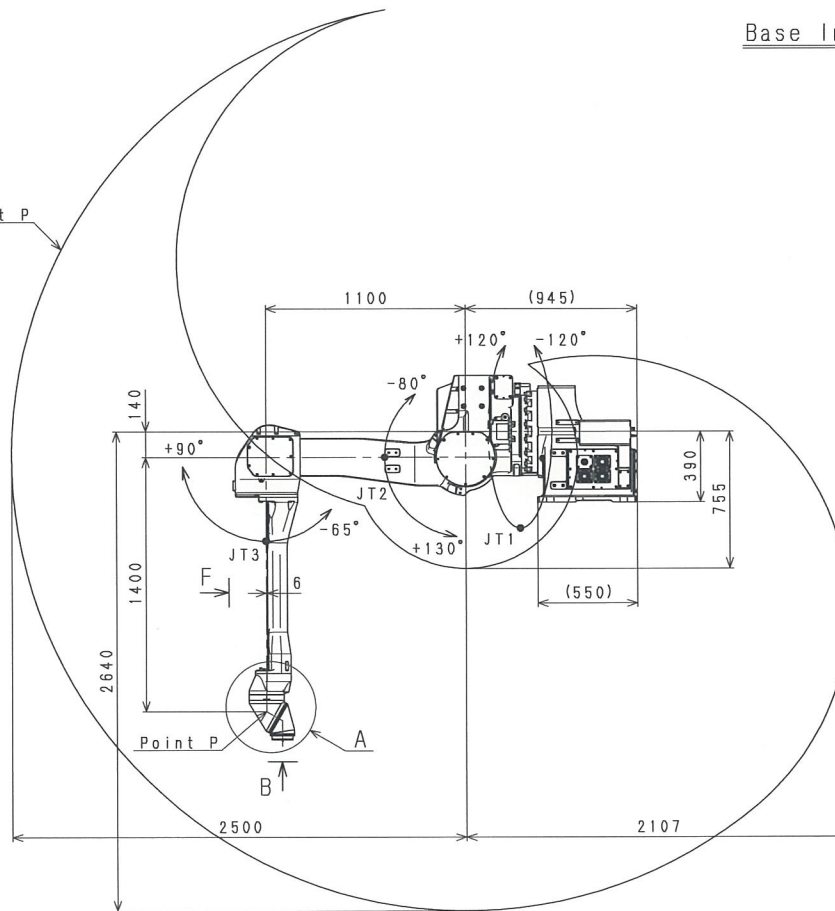

KJ264J-H1
WORKING RANGE