



Standard Specifications

KJ314J-D

(for E controller)

1st ed. 24-Jan-19

2nd ed. 31-Jan-25

Kawasaki Heavy Industries, Ltd.
Robot Business Division

Specification number : 90151-0216DEB

Robot specifications

1. Model	Installation mode	Standard	Mirror
	Wall mounting	KJ314J-D0	KJ314J-D1
2. Type	Articulated robot + Swing unit		
3. Degree of freedom	7 axes (6 axes + 1 axis)		
4. Max. payload	Wrist : 15 kg (at the tool mounting surface) Upper arm : 25 kg (including painting equipment in the pressurized chamber)		
5. Max. reach	3,100 mm		
6. Position repeatability	±0.5 mm (wrist flange surface) conforms to ISO 9283		
7. Max. painting speed	1,500 mm/s (at the center of tool mounting surface)		
8. Axis specification	Operating axis	Motion range	
	Arm rotation (JT1)	±120°	
	Arm out-in (JT2)	+ 130° - - 80°	
	Arm up-down (JT3)	+ 90° - - 65°	
	Wrist swivel (JT4)	±720°	
	Wrist bend (JT5)	±720°	
	Wrist twist (JT6)	±410°	
	Swing (JT7)	±90°	
9. Load capacity of wrist		Max. torque	Moment of inertia*
	JT4	56.2 N·m	2.19 kg·m ²
	JT5	43.4 N·m	1.31 kg·m ²
	JT6	22.0 N·m	0.33 kg·m ²
	Note* Each value in this table shows allowable moment of inertia of JT4/JT5/JT6 when max. allowed torque is applied to each axis. If more detailed data is required for your application, please contact Kawasaki.		
10. Mass	720 kg (without options)		
11. Mounting	Wall mounting		
12. Installation Environment	Ambient Temperature :	0 - 40 °C	
	Relative Humidity :	35 - 85 % (with no dew condensation)	
13. Color	Munsell 10GY9/1 equivalent		
14. Explosion proof	Pressurized and intrinsically safe		
15. Air supply to the manipulator	Clean & dry air	0.5 Nm ³ /min, 0.4 - 0.7 MPa	
	Dew point	- 17 or less at atmospheric pressure	
	Solid material	0.01 μm or less	
	Oil content	Mist separation 99.9999% or more	
16. Options	Mechanical stopper	Adjustable stoppers JT1/JT2/JT3	
	Painting equipment	FGP motor (1 unit can be equipped with)	
		Solenoid valve for painting (up to 3 units can be equipped with)	
		Electro pneumatic converter for painting (up to 3 units can be equipped with)	
	Upper Arm Cover		
Application hose protection unit			

Consult Kawasaki about maintenance parts and spare parts.

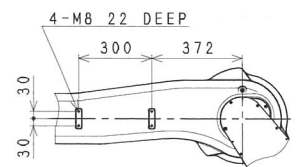
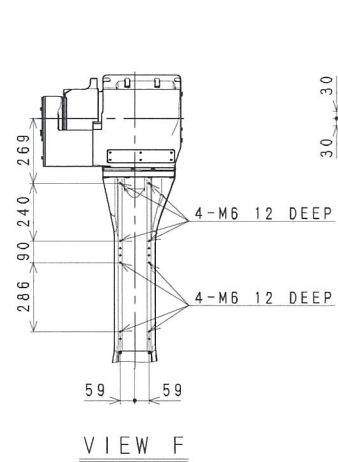
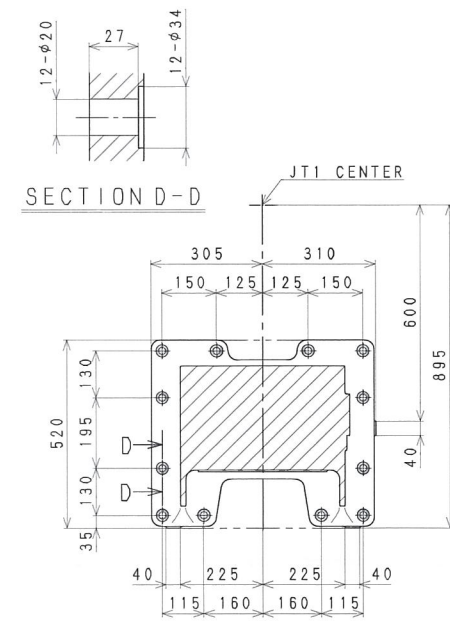
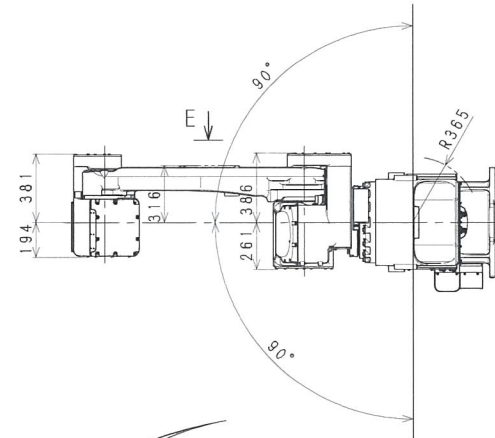
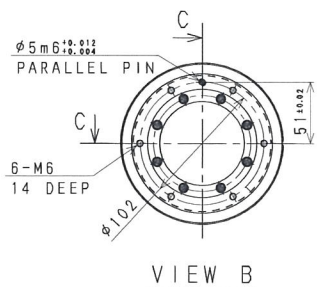
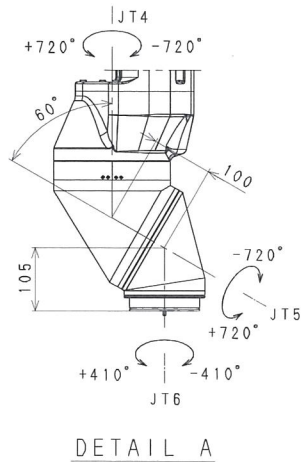
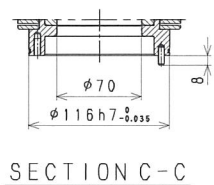

Working range based on point P

VIEW E

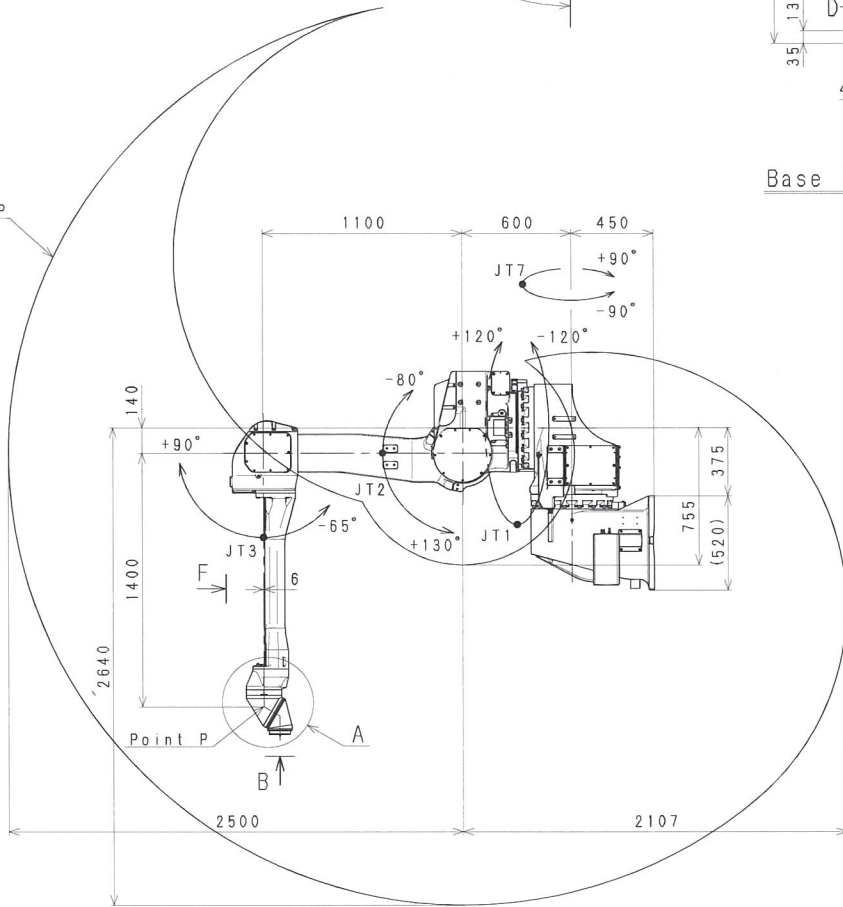
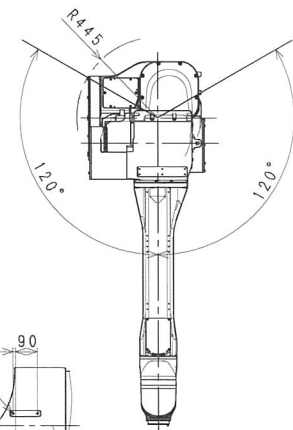

Base Installation Dimensions

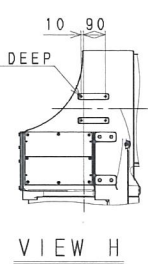
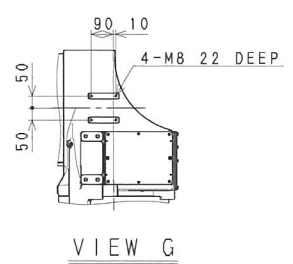
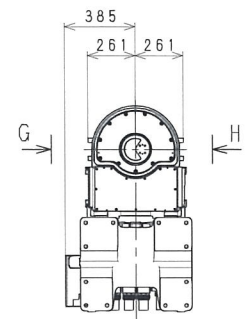

VIEW G

VIEW H

KJ314J-D1
WORKING RANGE